



*Serving the market for more than 25 years,
as EG&G Moisture and Humidity Systems.*

Model 1-C DewTrace™ Trace Moisture Analyzer

the DewTrace™ Electrolytic Hygrometer

Features

- Sensitivity below 1 ppm.
 - Fast response.
 - Long sensor life.
 - Low cost.
 - Flow insensitive.
 - Fundamental measurement of moisture content.
- Easy and inexpensive to replace sensing elements.

Applications

The DewTrace™ Trace Moisture Analyzer, Model 1-C, was designed specifically for monitoring ppm moisture levels in relatively clean, dry, inert gases.

Typical applications include:

- Semiconductor Industry for Monitoring Common Process Gases
- Gas Supplier Industry as a Quality Control Instrument
- Electric Power Industry for Checking Moisture Levels in Transformer Gases



Description

The DewTrace™ Trace Moisture Analyzer utilizes an electrochemical (phosphorus pentoxide— P_2O_5 , coated) sensor in combination with a proprietary semipermeable diffusion membrane. This membrane freely passes water vapor molecules while protecting the sensor from larger molecules which might adversely affect performance. The sensing element itself is an interdigitated wafer electrode and is manufactured using a unique procedure. It doesn't utilize a wire wound component.

The interconnecting cable length between the sensor housing and electronics is of minor importance since the sensor outputs a dc current. A six-foot length is provided. The electronics unit supplies power for the sensor and converts the received analog signal into a moisture value in ppm, which is then digitally displayed on the front panel. The electronics is equipped with a Stand-By position on the Function switch which allows the cell to remain dry when not sampling, and which also gives indication of proper functioning of the cell. This feature significantly reduces or eliminates the amount of drying time prior to startup. The electronics is also equipped with a cell Life Indicator which displays the useful life of the sensing element. If the sensing element is replaced, a Calibration Digital Switch, located on the rear panel, matches the new element to the electronics.

Principle of Operation

The electrochemical cell consists of a hygroscopic material, phosphorus pentoxide (P_2O_5), coated on a semiconductor electrode element. Voltages are applied to the electrodes such that adequate field strength is obtained to dissociate absorbed water into hydrogen and oxygen. The current flowing is proportional to the quantity of water dissociated (Faraday's Law of Electrolysis). Thus, this instrument, which measures the dissociation current, makes a FUNDAMENTAL MEASUREMENT of the moisture present.

Specifications, Model 1-C

Range:	0.1 to 500 PPM _v	Pressure Correction:	Calibrated at One Atmosphere. Output is Linearly Related to Pressure.
Accuracy:	±5% of Reading, Nominal	Sample Temperature:	0° to 50°C
Resolution:	0.1 PPM	Operating Temperature:	0° to 50°C
Hysteresis:	None	Output:	0 to 500 mVDC (1mV/PPM)
Sample Flow:	0.5 to 5.0 SCFH	Display:	3 1/2 Digit LED, PPM _v
Sample Flow Sensitivity:	Less than 1% Change in Readout for a 25% Change in Flow	Power:	115/230 VAC ± 10%, 50/60 Hz, Single Phase
Instrument Response Time:	90% of Step Change in One Minute, Typical	Weight:	9 lbs
Pressure:	0 to 200 psig		

Sensor Physical Dimensions

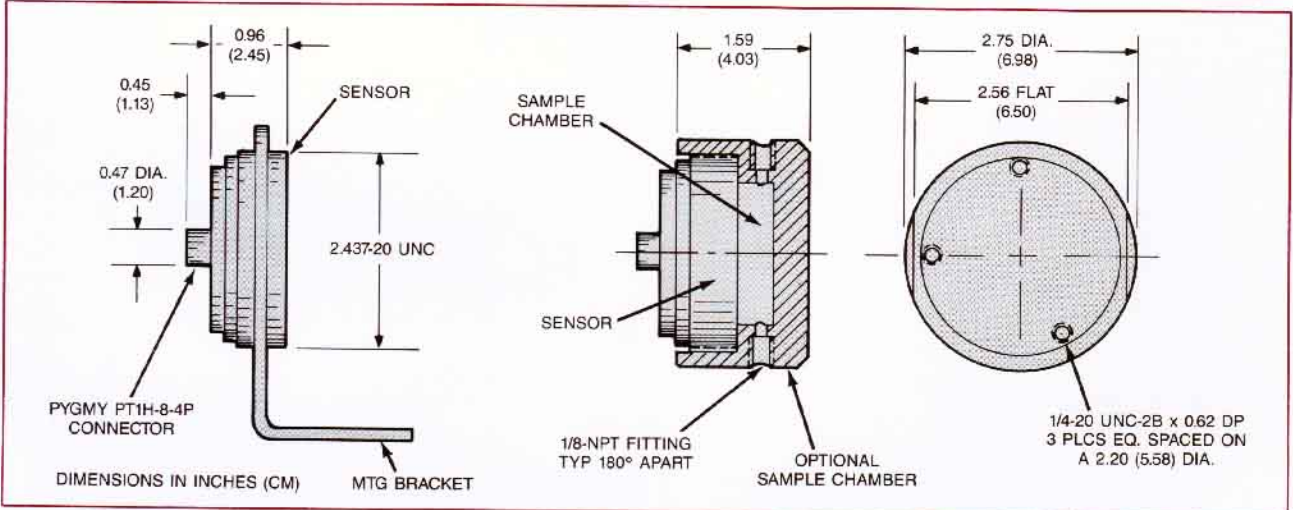

Features

This sensor design is easy to install, use, and maintain. The sensing element and membrane are mounted in a rugged 316SS stainless steel housing. The sensor assembly can be used in situ with its own mounting flange, or it can be used in a flow stream with the optional 316 Stainless Steel Sample Chamber. It is less subject to contamination than other sensors because of the membrane. ALSO, WHEN OTHER OXIDE SENSORS FAIL, THE WHOLE SENSOR OFTEN NEEDS TO BE REPLACED—A VERY COSTLY PROCEDURE. IN THIS SENSOR, ONLY THE MEMBRANE AND/OR WAFER ELECTRODE WOULD REQUIRE REPLACEMENT—AN EASY, INEXPENSIVE TASK. Measurements are very repeatable. Since measurements are independent of the mass of gas, the inaccuracies and calibration problems associated with most other electrochemical sensors are eliminated.

NOTE

The instrument should not be used with gases which are corrosive, or which readily combine with phosphorus pentoxide to form water. Gases and materials that should be avoided include certain acids, alcohol, chlorine, fluorine, hydrogen chloride, hydrogen fluoride, amines, ammonia, alkynes, alkenes, and alkenes.

Options/Accessories

- Sample Chamber, 316SS, 1/8-inch NPT inlet/outlet
- Sensor Extension Cable
- Sensor Mounting Bracket
- Analog Output Cable with Connector



Specifications are nominal and subject to change without notice.

455 FORTUNE BOULEVARD • MILFORD, MA 01757
TEL: (508) 478-9500 • TOLL FREE (USA): (800) 276-3729 • FAX: (508) 634-3010 • E-MAIL: h2o@edgetech.com

The Model 1-C DewTrace™ is proudly produced by our quality team in the USA.

Copyright ©
EdgeTech
All Rights Reserved
Printed in U.S.A. 10/96