

Model 217

Ultra High Purity Pressure Transducers

Gauge, Compound and Absolute PSI and Bar Ranges



Setra's Model 217 Transducer is designed for modular "Block" gas sticks and panels. The 217 is ideal for pressure measurement applications that require exceptional insensitivity to environmental extremes, such as temperature transients resulting from the flow of cold gas.

The 217 has a small swept sensor chamber for easy purgeability. All wetted parts are high quality VAR 316LSS, electropolished to 7 Ra (10 max.) finish. Every sensor is mass spectrometer helium leak tested to 1×10^{-9} atm.cc/sec.

The 217 is offered with a 5 VDC, 10 VDC or 4-20 mA output. A variety of standard electrical terminations are offered.

The top external zero and span adjustments complete this unique design for all UHP down mount applications.

Setra's patented variable capacitance sensor features a 316L stainless steel diaphragm and an insulated electrode plate. A variable capacitor is formed between the sensor body and the electrode plate. An increase in pressure causes a slight rounding of the diaphragm, which decreases the capacitance. The capacitance change is detected and converted to a highly accurate linear DC electric signal by Setra's unique custom integrated circuit, utilizing a patented charge balance principle.

Setra's entire Ultra-High Purity series is based on Setra's proven capacitive sensing technology with highly accurate and stable voltage or current output signals that are virtually EMI/RFI immune.

Pressure Ranges

0 psig, 0 psia or -14.7 psig to:	Bar Ranges -1 or 0 to:	Proof Pressure (psi)	Burst Pressure (psi)
10	0.7	20	500
25	1.7	40	1500
50	3.4	75	3000
100	7	150	3000
250	17	350	5000
500	35	650	7500
1000	70	1250	7500
2000	138	2500	8000
3000	200	3500	10,000

NOTE: Setra quality standards are based on ANSI-Z540-1. The calibration of this product is NIST traceable.

U.S. Patent nos. 3859575

159 Swanson Road, Boxborough, MA 01719/Telephone: 978-263-1400/Fax: 978-264-0292

Applications

- Modular "Block" Gas Sticks and Panels
- High Purity Gas Delivery Systems
- Semiconductor Process Tools

Benefits

- Superior Stability Avoids Downtime
- EMI/RFI Immunity Prevents False Shutdown
- Sturdy Design Allows Trouble Free Installations
- Meets CE Conformance Standards

When it comes to a product to rely on - choose the Model 217. When it comes to a company to trust - choose Setra - an ESOP (Employee Owned) Company.



Visit Setra Online:
<http://www.setra.com>

setra

800-257-3872

Model 217 Specifications

Performance Data

Accuracy RSS* (at constant temp)	±0.25% FS or ±1.0% Reading
Non-Linearity, BFSL	±0.15% FS
Hysteresis	0.20% FS
Non-Repeatability	0.02% FS

Thermal Effects**

Compensated Range °F(°C)	+15 to +150 (-9 to +65)
Zero Shift %FS/100°F(50°C)	2.0 (1.8)
Span Shift %FS/100°F(50°C)	2.0 (1.8)

*RSS of Non-Linearity, Non-Repeatability and Hysteresis.

**Units calibrated at nominal 70°F. Maximum thermal error computed from this datum.

Environmental Data

Temperature	
Operating °F (°C)	-40 to +185 (-40 to +85)
Storage °F (°C)	-40 to +185 (-40 to +85)

*Operating temperature limits of the electronics only.

Pressure media temperatures may be considerably higher or lower.

Physical Description

Case	Stainless Steel
Electrical Connection	6ft. Multiconductor Cable, Bayonet or D-sub Connector
Pressure Fitting	Down mount "C" Seal
Vent	Through Zero and Span Access Screws
Weight	6.5 oz (184g)

Electrical Data (Voltage)

Circuit	3-Wire (Exc, Out, Com)
Excitation	10 to 30VDC for 5V FSO 13 to 30VDC for 10V FSO
Output*	0 to 5VDC or 0.2 to 5.2 VDC** 0 to 10VDC or 0.2 to 10.2 VDC**

Current Consumption < 8 mA

*Calibrated into a 50K ohm load, operable into a 5000 ohm load or greater.

**Zero output factory set to within ±25mV (for 5 VDC output) or ±50mV (for 10VDC output).

**Span (Full Scale) output factory set to within ±25mV (for 5 VDC output) or ±50mV (for 10VDC output).

Electrical Data (Current)

Circuit	2-Wire
Output*	4 to 20 mA**
External Load	0 to 800 ohms
Minimum supply voltage (VDC)	= 10 + 0.02 x (Resistance of receiver plus line).
Maximum supply voltage (VDC)	= 30 + 0.004 x (Resistance of receiver plus line).

*Calibrated at factory with a 24 VDC loop supply voltage and a 250 ohm load.

**Zero output factory set to within ±0.8mA.

**Span (Full Scale) output factory set to within ±0.8mA.

Pressure Media

Liquids or gases compatible with 316L Stainless Steel.

Specifications subject to change without notice.

Outline Drawings

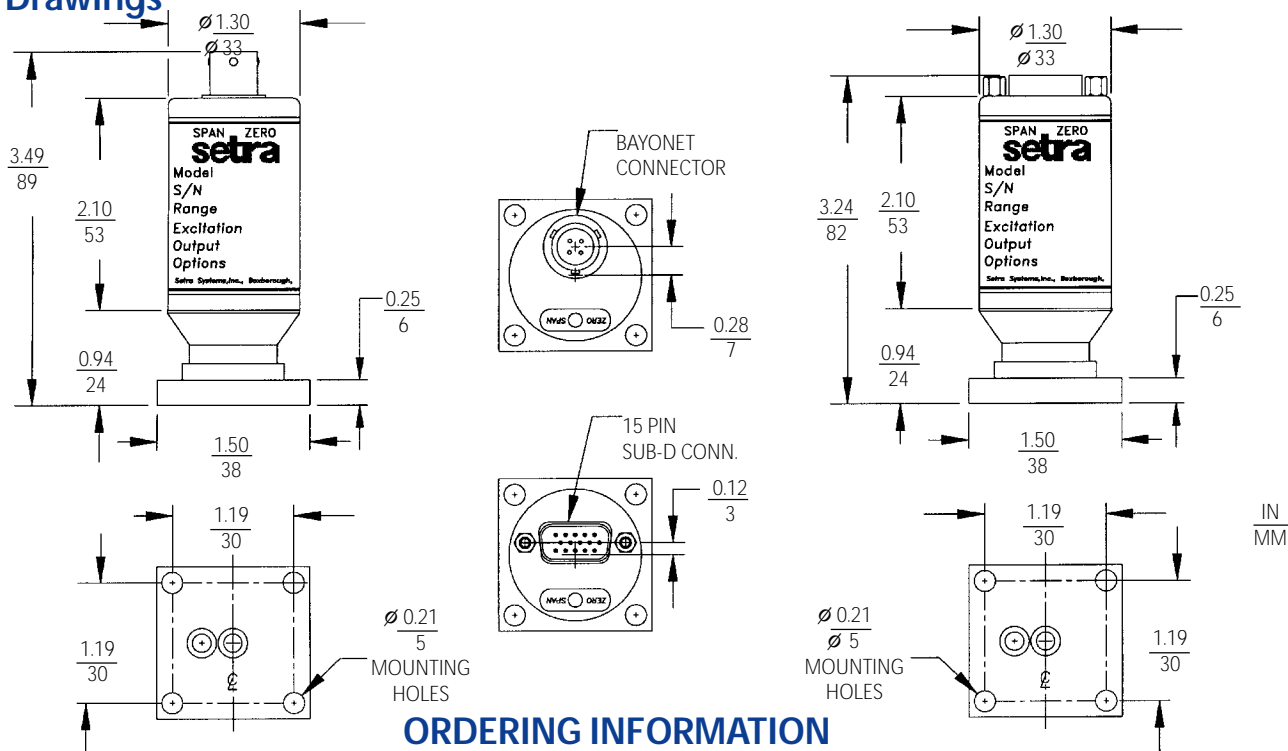

ORDERING INFORMATION

Code all blocks in table.

Example: Part No. 2171100PGE123D1F for a 217 Transducer 0 to 100 PSIG, Down Mount "C" Seal Flange, 0.2 to 5.2 VDC Output, 15 pin D-sub Connector and ±0.25% FS Accuracy.

Model	Range	Pressure	Pressure Fitting	Output	Elec. Termination	Accuracy	
2171 = 217	010P = 10 PSI 025P = 25 PSI 050P = 50 PSI 100P = 100 PSI 250P = 250 PSI 500P = 500 PSI 10CP = 1000 PSI 20CP = 2000 PSI 30CP = 3000 PSI	007B = 7 BAR 017B = 17 BAR 035B = 35 BAR 070B = 70 BAR 200B = 200 BAR	G = Gauge C = Compound A = Absolute	E1 = Down Mount "C" Seal	11 = 4-20mA 2B = 0-5 VDC 2C = 0-10 VDC 33 = 0.2-5.2 VDC 59 = 0.2-10.2 VDC N1 = 4-20 mA (Class 1, Groups A, B, C, D, Division 2 Locations)	06 = 6 ft. Multiconductor Cable B1 = 4 pin Bayonet Connector D9 = 9 pin, D-sub Connector D1 = 15 pin, D-sub Connector M1 = 5 pin, Mini DIN Connector	F = ±0.25% FS (w/Calibration Certificate) J = ±1.0% Reading (w/Calibration Certificate)

Please contact factory for configurations not shown.

While we provide application assistance on all Setra products, both personally and through our literature, it is the customer's responsibility to determine the suitability of the product in the application.

159 Swanson Road, Boxborough, MA 01719/Tel: 978-263-1400;
Toll Free: 800-257-3872; Fax: 978-264-0292; email: sales@setra.com