

Installation Guide

Model 223

Ultra-High Purity Flow-Through
Pressure Transducer



setra



1-800-257-3872 **Toll Free**

1-978-264-0292 **Fax**

www.setra.com **Web Site**

Setra Model 223

Ultra High Purity Flow-Through Pressure Transducer

1.0 GENERAL INFORMATION

Every Model 223 has been tested and calibrated before shipment. Model 223 performance specifications are listed on Page 6 of this Guide.

Setra Systems 223 pressure transducers sense gauge, compound or absolute pressure and convert this pressure to a proportional high level analog output. Two output versions are offered: A voltage output of 5 VDC FSO (Full Scale Output) and 10 VDC FSO, and a current output of 4 to 20 mA.

Note: These instructions are also available on our web site at www.setra.com.

EMC Certification

This product complies with EN61326 Electrical Equipment for Measurement, Control and Laboratory use – EMC Requirements for Minimum Requirements and Industrial Locations. Special caution should be taken to meet Standard EN61000-4-5:1995 Surge Immunity if any of the following conditions apply to the installation: The product is installed outside; all or any part of the cable is exposed to the outside; the cable is greater than 30 meters in length. In order to meet the Surge Immunity requirements, the following conditions must be followed during installation:

1. Shielded cable must be used, and the shield must be tied to earth ground (not power supply ground) on at least one end of the cable shield/drain wire. The shield must be maintained all the way from sensor to the power supply.
2. If unshielded cable is used, an earth grounded metal conduit fitting can be used to replace the shielded cable.
3. For a sensor with a metal body or enclosure, the body/enclosure must be grounded to earth. If a protective metal housing is used, the metal housing should be grounded to earth.
4. If a protective plastic housing is used, the housing must be able to withstand at least 2 KV from the housing to earth ground, without damaging the circuit.

2.0 MECHANICAL INSTALLATION

2.1 Media Compatibility

Model 223 transducers are designed to be used with any gas or liquid compatible with 316L Stainless Steel. Never submerge the transducers in any liquid.

2.2 Environment

The operating temperature limits of the 223 are as follows:

Operating Temperature Range°F (°C)	-40 to +185 (-40 to +85)
Compensated Temperature Range°F (°C)	+15 to +150 (-9 to +65)
Current unit ordered with Option N1:	
Operating Temperature Range°F (°C)	-22 to +176 (-30 to +80)
Compensated Temperature Range°F (°C)	+15 to +150 (-9 to +65)

2.3 Pressure Fittings

Mounting - Model 223 pressure transducers can be installed with Face Seal Fittings or can be butt welded into place.

NOTE: Welding purge gases are very hot! It is important to flow hot purge gases away from the transducer. Disconnect all electrical connections to transducer when welding.

When installing units with Face Seal Fittings:

- a) Align piping system to transducer connections
- b) Hand tighten nuts
- c) Torque nuts by placing wrenches on nuts only (or on nut and wrench flats of transducer body for units with fixed male face seals) **Never hold the unit by the electronics housing during installation.**

2.4 Venting

Model 223 transducers are vented through the electronics housing.

3.0 ELECTRICAL INSTALLATION

3.1 Voltage Output Units

The Model 223 voltage output transducer is supplied with a 6ft. multiconductor cable or Bayonet style connector. The voltage output is either 5 VDC FSO or 10 VDC FSO. Diagram 1 shows electrical connection wiring for voltage output transducers, and the excitation required.

CONNECTOR PIN WIRING FOR VOLTAGE OUTPUT TRANSDUCERS

CONNECTION	CABLE WIRE	BAYONET PIN
+ EXCITATION	RED	A
+ OUTPUT	GREEN	B
- OUTPUT	WHITE	C
- EXCITATION	BLACK	D
CASE GND	DRAIN	SHELL
EXCITATION: 10-30 VDC FOR 0.2 TO 5.2 VDC and 0 to 5 VDC 13-30 VDC FOR 0.2 TO 10.2 VDC and 0 to 10 VDC		

Diagram 1

Note: Model 223 can be wired as a 3-wire device by connecting - OUTPUT and -EXCITATION and drain wire to a common ground. However, accuracy may be reduced due to increase in resistance.

3.2 Current Output Units (and w/N1 option, see Notes 2 and 3.)

The Model 223 is a two-wire loop-powered 4 to 20mA current output unit and delivers rated current into any external load of 0-800 ohms. The Model 223 is available with 6ft. of multiconductor cable or Bayonet style connector. Diagram 2 shows electrical connection wiring for current output transducers.

CONNECTOR PIN WIRING FOR CURRENT OUTPUT TRANSDUCERS

CONNECTION	CABLE WIRE	BAYONET PIN
+ EXCITATION	RED	A
- EXCITATION	BLACK	D&B
CASE GND	DRAIN	SHELL

Minimum Supply Voltage = $10 + 0.02 \times \text{Loop Resistance}$

Diagram 2

The power supply must be a DC voltage source with a voltage range between 10 VDC and 30 VDC measured between the + and - terminals. The unit is calibrated at the factory with a 24 VDC loop supply voltage and a 250 ohm load.

Current must flow in one direction only - **Please observe polarity.** (See Diagram 3.) We suggest that the cable shield Drain Wire be connected to the system's loop circuit ground for optimum electrical noise rejection. On transducers with an integral Bayonet connector, connection to transducer case ground can be achieved by connecting the cable drain/shield wire to the mating cable-mounted connector shell (see Note 1).

Note1: The transducer case and integral Bayonet Connector shell, are electrically connected.

Note 2: ETL Listed to UL1604 Standards:The current output unit (excluding units ordered with the Mini Din Shell) may be installed in UL1604 Class 1 Hazardous (Classified) Group A, B, C, D, Division 2 locations if the unit is ordered for these locations. (This is denoted by an N1 designation in the Part Number, 12th and 13th digits.) Safety barriers are not required as long as the unit is operated under normal conditions with a maximum excitation voltage of 30 VDC between the input terminals.

Note 3: ATEX 94/9/EC Approved:Special hazardous area instructions for 223 transducers (with the N1 suffix) with ATEX approval: The 223 transducer (with the N1 suffix) is designed for use in hazardous areas indoor applications with ATEX rating: Non-incendive II 3G Eex nL IIC T4 X -30°C<Ta<+80°C. (Note: Units ordered with the Mini Din Shell are not ATEX approved for use in hazardous locations.)

- The device can only be used for "Indoor Applications"
- Power must be turned off before connecting or disconnecting.
- For the connector version, the connector must be secured before applying power and DO NOT SEPARATE WHEN ENERGIZED.
- The shielded cable must be used and the drain wire of the cable must be connected to the earth ground. The drain wire of the cable must connect to the connector metal outer shell for the connector version.
- The maximum allowable transient disturbance must not exceed more than 40% of the maximum excitation voltage.

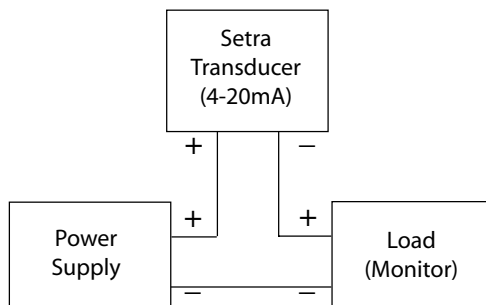

Diagram 3

4.0 CALIBRATION

The 223 transducer is factory calibrated to the specific input pressure range vs. output voltage or current and should require no field adjustment. For absolute pressure ranges, the zero can be adjusted with full vacuum applied to the pressure port. For compound ranges, the zero should be adjusted with the unit at atmospheric pressure and the output adjusted as noted in Diagrams 4 & 5 on pages 5 & 6. Zero and span adjustments can be made by turning the rotatable cover to expose the zero and span potentiometers. *Be certain to close the rotatable cover after adjustments are made.*

4.1 Voltage Output Zero Adjustment

While monitoring the voltage between the positive output (+OUT) and common (COM), and with the pressure port open to atmosphere, or with zero pressure applied, the zero may be adjusted by turning the zero potentiometer screw. For the 5 VDC Full Scale Output, the tolerance on zero and span settings is $\pm 25\text{mV}$. For the 10 VDC Full Scale Output, the tolerance on zero and span settings is $\pm 50\text{mV}$. For absolute pressure ranges, the zero should be adjusted with a full vacuum applied. See the chart below for nominal “installed” output at atmospheric pressure for compound pressure ranges.

NOMINAL “INSTALLED” OUTPUT AT ATMOSPHERIC PRESSURE

PSI Compound Range	5 VDC Full Scale Outputs		10 VDC Full Scale Outputs	
	0.2 to 5.2 Voltage (VDC)	0 to 5 VDC Voltage (VDC)	0.2 to 10.2 Voltage (VDC)	0 to 10 VDC Voltage (VDC)
	(Factory Set to within $\pm 25\text{mV}$)		(Factory Set to within $\pm 50\text{mV}$)	
-14.7 to 25	2.051	1.851	3.903	3.703
-14.7 to 50	1.336	1.136	2.472	2.272
-14.7 to 100	0.841	0.641	1.482	1.282
-14.7 to 250	0.478	0.278	0.755	0.555
-14.7 to 500	0.343	0.143	0.486	0.286
-14.7 to 1000	0.272	0.072	0.345	0.145
-14.7 to 3000	0.224	0.024	0.249	0.049

Bar Compound Range	5 VDC Full Scale Outputs		10 VDC Full Scale Outputs	
	0.2 to 5.2 Voltage (VDC)	0 to 5 VDC Voltage (VDC)	0.2 to 10.2 Voltage (VDC)	0 to 10 VDC Voltage (VDC)
	(Factory Set to within $\pm 25\text{mV}$)		(Factory Set to within $\pm 50\text{mV}$)	
-1 to 1.7	2.052	1.851	3.904	3.704
-1 to 3.4	1.336	1.136	2.473	2.273
-1 to 7	0.825	0.625	1.450	1.250
-1 to 17	2.494	0.278	0.756	0.556
-1 to 35	0.339	0.139	0.478	0.278
-1 to 70	0.270	0.070	0.341	0.141
-1 to 200	0.225	0.025	0.250	0.050

Diagram 4

4.2 Voltage Output Span Adjustment

(Complete the zero adjustment before setting span.)

Span or full scale output adjustments should only be performed by using an accurate pressure standard (electronic manometer, digital pressure gauge, etc.), with at least comparable accuracy to the 223 transducer ($\pm 0.25\%$ FS).

With full range pressure applied to the pressure port, the span may be adjusted by turning the span potentiometer screw. The span (full scale) output is factory set to within $\pm 25\text{mV}$ for the 5 VDC FS output or $\pm 50\text{mV}$ 10 VDC FS output.

4.3 Current Output Zero Adjustment

While monitoring the current output, and with the pressure port open to atmosphere or with zero pressure applied, the zero may be adjusted by turning the zero potentiometer screw. The factory setting is 4mA (± 0.08 mA). For absolute pressure ranges, the zero should be adjusted with a full vacuum applied. For compound pressure ranges, the zero should be adjusted with the unit at atmospheric pressure and the output adjusted as noted in Diagram 5 below.

Note: When it is not possible to vent input pressure for zero adjustment (ie., hazardous gasses), zero may be adjusted by pulling a vacuum and setting the unit to 4.0 mA (± 0.08 mA). This method may result in a small zero setting error due to variations in barometric pressure.

NOMINAL "INSTALLED" OUTPUT AT ATMOSPHERIC PRESSURE

BAR COMPOUND RANGE	CURRENT OUTPUT (mA)	PSI COMPOUND RANGE	CURRENT OUTPUT (mA)
-1 to 1.7	9.92	-14.7 to 25	9.92
-1 to 3.4	7.63	-14.7 to 50	7.63
-1 to 7	6.00	-14.7 to 100	6.05
-1 to 17	4.88	-14.7 to 250	4.89
-1 to 35	4.44	-14.7 to 500	4.46
-1 to 70	4.22	-14.7 to 1000	4.23
-1 to 200	4.07	-14.7 to 3000	4.08

Diagram 5

4.4 Current Output Span Adjustment

Span or full scale output adjustments should only be performed by using an accurate pressure standard (electronic manometer, digital pressure gauge, etc.) with at least comparable accuracy to the 223 transducer ($\pm 0.25\%$ FS). With full range pressure applied to the pressure port, the span may be adjusted by turning the span potentiometer screw. The span (full scale) output is factory set to within ± 0.08 mA.

5.0 MODEL 223 PERFORMANCE SPECIFICATIONS

Accuracy RSS* (at constant temperature.) $\pm 0.25\%$ FS

Non-Linearity, BFSL $\pm 0.15\%$ FS

Hysteresis 0.20% FS

Non-Repeatability 0.02% FS

*RSS of Non-Linearity, Non-Repeatability and Hysteresis.

Thermal Effects

Compensated Range °F(°C) +15 to +150 (-9 to +65)

Zero Shift %FS/100°F (50°C) ± 2.0 (± 1.8)

Span Shift %FS/100°F (50°C) ± 2.0 (± 1.8)

Warm-up Shift $< \pm 0.1\%$ FS total

Environmental

Temperature

Operating** °F(°C) -40 to +185 (-40 to 85)

Storage °F(°C) -40 to +185 (-40 to 85)

Current unit ordered with Option N1:

Operating** °F (°C) -22 to +176 (-30 to +80)

Storage °F (°C) -22 to +176 (-30 to +80)

6.0 RETURNING PRODUCTS FOR REPAIR

Please contact a Setra application engineer (800-257-3872, 978-263-1400) before returning unit for repair to review information relative to your application. Many times only minor field adjustments may be necessary. When returning a product to Setra, the material should be carefully packaged, accompanied by the "Service/Repair/Calibration Order Return" form on page 8 and shipped to :

Setra Systems, Inc.
159 Swanson Road
Boxborough, MA 01719-1304
Attn: Repair Department

Note: Return order form is also available on Setra's web site @ www.setra.com.

To assure prompt handling, please supply the following information and include it inside the package or returned material (Return Order Form provided on page 8):

1. Name and phone number of person to contact.
2. Shipping and billing instructions.
3. Full description of the malfunction.
4. Identify any hazardous material used with product.

Notes: Please remove any pressure fittings and plumbing that you have installed and enclose any required mating electrical connectors and wiring diagrams.

Allow approximately 3 weeks after receipt at Setra for the repair and return of the unit. Non-warranty repairs will not be made without customer approval and a purchase order to cover repair charges.

Calibration Services

Setra maintains a complete calibration facility that is traceable to the National Institute of Standards & Technology (NIST). If you would like to recalibrate or recertify your Setra pressure transducers or transmitters, please call our Repair Department at 800-257-3872 (978-263-1400) for scheduling.

7.0 WARRANTY AND LIMITATION OF LIABILITY

SETRA warrants its products to be free from defects in materials and workmanship, subject to the following terms and conditions: Without charge, SETRA will repair or replace products found to be defective in materials or workmanship within the warranty period; provided that:

- a) the product has not been subjected to abuse, neglect, accident, incorrect wiring not our own, improper installation or servicing, or use in violation of instructions furnished by SETRA;
- b) the product has not been repaired or altered by anyone except SETRA or its authorized service agencies;
- c) the serial number or date code has not been removed, defaced, or otherwise changed; and
- d) examination discloses, in the judgment of SETRA, the defect in materials or workmanship developed under normal installation, use and service;
- e) SETRA is notified in advance of and the product is returned to SETRA transportation prepaid.

Unless otherwise specified in a manual or warranty card, or agreed to in writing and signed by a SETRA officer, SETRA pressure and acceleration products shall be warranted for one year from date of sale.

The foregoing warranty is in lieu of all warranties, express, implied or statutory, including but not limited to, any implied warranty of merchantability for a particular purpose.

SETRA's liability for breach of warranty is limited to repair or replacement, or if the goods cannot be repaired or replaced, to a refund of the purchase price. SETRA's liability for all other breaches is limited to a refund of the purchase price. In no instance shall SETRA be liable for incidental or consequential damages arising from a breach of warranty, or from the use or installation of its products.

No representative or person is authorized to give any warranty other than as set out above or to assume for SETRA any other liability in connection with the sale of its products.

SERVICE/REPAIR/CALIBRATION ORDER RETURN FORM

Setra Systems, Inc.

159 Swanson road
Boxborough, MA 01719

Repair Dept. Fax #:978-266-2158/Phone #:978-266-2194

☆ All lines must be filled out.

☆ This form must accompany all returns. Returns that arrive with no information will be rejected.

CONTACT NAME: _____ EMAIL ADDRESS: _____
COMPANY: _____ DATE: _____
PHONE NUMBER: _____ FAX NUMBER: _____

PURCHASE ORDER WITH "NOT TO EXCEED" AMOUNT	CREDIT CARD #, EXP. DATE / CARDHOLDER NAME:
_____	_____
_____	_____

MODEL / PART # AND QTY: _____ SERIAL NUMBER/S: _____

- EXPEDITE , 1-3 days (\$50 FEE) RUSH, 5-7 days STD TIME, 2-3 weeks
 CALIBRATION ONLY CERT NEEDED FAILURE ANALYSIS

REASON FOR RETURN/DESCRIPTION OF PROBLEM: _____

NOTES/COMMENTS OR SPECIAL HANDLING _____

Any product that has been used with Hazardous Materials must be 100% purged and should be accompanied by a MSDS sheet, bagged, sealed, and tagged accordingly. **Setra will not accept delivery of any product exposed to chemicals, radioactive agents, or biological process without evidence of decontamination or laboratory analysis, and proof the biological process is not harmful.**

Hazardous chemicals: Yes No (circle one)
List of Chemicals used? _____
Has unit been purged? Yes ___ No ___ Purged with what? _____
Has unit been flushed? Yes ___ No ___ Flushed with what? _____
Has unit been decontaminated: Yes ___ No ___ Explain Process: _____
All wetted surfaces have been removed: Yes No

Billing Address:	Shipping Address
_____	_____
_____	_____
_____	_____

Method of Shipment: _____
PPD: Yes Collect: Yes Please list account # _____

SS2047 RevID 08/24/04