

Setra Local Display

Model LD330

Installation and Operating Instructions.

Setra's Model LD330 is a small local display designed for convenient in-line installation. It can be used with voltage output and current output transducers 4-pin bayonet connectors (which meet dimensional requirements of MIL-C-26482 and the MIL STD 3116) Amp jack, 15 Pin and 9 Pin D-Sub connectors.

1.0 INSTALLATION

The LD330 can be supplied with a variety of integral electrical connectors to connect to the mating connectors on the transducer. Consult part number chart below to determine the proper configuration. For setting optimum viewing angle, the LD330 display housing can rotate, at least 270 degrees, with respect to the connector. **DO NOT ATTEMPT TO FORCE ROTATIONAL ADJUSTMENT BEYOND STOP POSITION.**

The LD330 is available in a variety of configurations.

2.0 ELECTRICAL CONNECTIONS

The LD330 can be supplied with different style connectors to the input transducer and to the power supply. The power supply can be supplied with cable, also. Confirm the electrical connection supplied, and refer to the appropriate column below for proper connections.

2.1 Voltage Units

	CABLE WIRE	BAYONET PIN	9 PIN D-SUB PIN	15 PIN D-SUB PIN	5 PIN MINI-DIN PIN	MOLEX
CONNECTION						
+ EXCITATION	RED	A	4	7	1	2
+ OUTPUT	GREEN	B	1	2	2	1
- OUTPUT	WHITE	C	8	12	4	4
- EXCITATION	BLACK	D	9	5	5	5
CASE GND	DRAIN	SHELL	SHELL	SHELL	3	6

2.2 Current Units

	CABLE WIRE	BAYONET PIN	9 PIN D-SUB PIN	15 PIN D-SUB PIN	5 PIN MINI-DIN PIN	MOLEX
CONNECTION						
+ EXCITATION	RED	A	4	7	1	2
- EXCITATION	BLACK	D & B	9	5	4	5
CASE GND	DRAIN	SHELL	SHELL	SHELL	3	6

3.0 PANEL-MOUNT CONFIGURATION

If the panel-mount configuration is supplied, see Figure 1 for cut-out dimensions. Insert the panel-mount display through the front and secure to the panel with four mounting screws (not supplied).

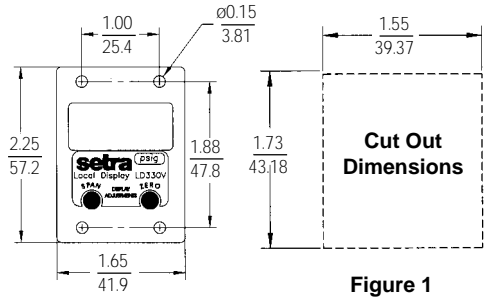

Figure 1

4.0 CALIBRATION

The LD330 is factory calibrated to display engineering units. The multi-turn pots on the front face are for zero and span display adjustment. Setra recommends that the zero adjustments be done using the transducer zero potentiometer whenever possible. The display zero potentiometer should only be used for minor adjustments. Never adjust the span potentiometer unless proper calibration equipment is used and proper calibration procedures are followed.

4.1 Zero & Sensitivity Adjustment

The zero and sensitivity (span) potentiometer are located on the front of the unit just under the digital display. Remove the protective plugs to access the potentiometers.

1. Apply zero pressure to the transducer and adjust the LD330's zero potentiometer if the LD330 does not display "0".

Note: For a compound range (eg -14.7 to 100 psig unit) apply "0" psig pressure to the transducer and adjust the LD330 zero potentiometer until the display is "0". Do not apply -14.7 psig and attempt to adjust the display to "-14.7".

2. Apply full scale output to the transducer/transmitter and adjust the span potentiometer on the LD330 if the LD330 does not display the correct value. If the adjustment seems sensitive verify that the LD330 is the correct range for your transducer. Repeat steps 1 and 2 as necessary.

4.2 Decimal Points

The LD330 decimal point is factory set to custom specified range. Figure 2 below shows the jumper settings required for decimal point settings.

To access this jumper, remove the 2 screws on the backside of the LD330 housing and remove the back cover. Remove jumper if decimal point is not required.

4.3 Backlighting

The LD330V comes standard with green backlighting. LD330C is not offered with backlighting. To disable backlighting of LD330V, remove the Back Light Jumper shown in figure below.

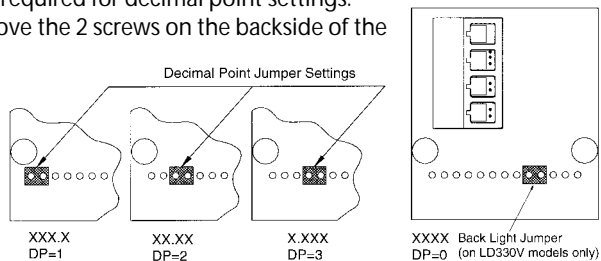

Figure 2

5.0 SPECIFICATIONS

	LD 330V	LD 330C
Display	Voltage Input Display	Loop Powered Display
Digits	-999 to 1999	-999 to 1999
Type	7 Segment LCD, Green Backlight	7 Segment LCD (Backlit Optional)
Polarity	Automatic (-) display	Automatic (-) display
Overload	1 followed by blank display	1 followed by blank display
Accuracy	0.25% of reading \pm 1 count	0.25% of reading \pm 1 count
Environmental		
Operating Temp.	32°F to 140°F (0C to 60C)	32°F to 140°F (0C to 60C)
Storage Temp.	-40°F to 158°F (-20C to 70C)	-40°F to 158°F (-20C to 70C)
Temp. Coeff.	100 ppm/C	100 ppm/C
Electrical Data		
Input Signal	0.2 to 5.2 VDC	4-20 mA loop powered
Excitation	8 VDC to 30 VDC 300k ohm min input impedance 30 mA current consumption 3 mA with backlight disabled At 32 VDC = 15 mA	4 VDC max voltage drop
Zero/Span Adjust	Multi-Turn potentiometers	Multi-Turn potentiometers
Protection	Reverse polarity protection	100 mA current limit

TABLE 1 CONFIGURABLE PART NUMBER

Example: Part No. 3301-V-3-C-B-T is a Model 330 with 0.2 to 5.2 VDC input, 100.0 pressure range, compound pressure, Bayonet-Female-Bottom connection to transducer and a Bayonet-Male-Top connection to power supply.

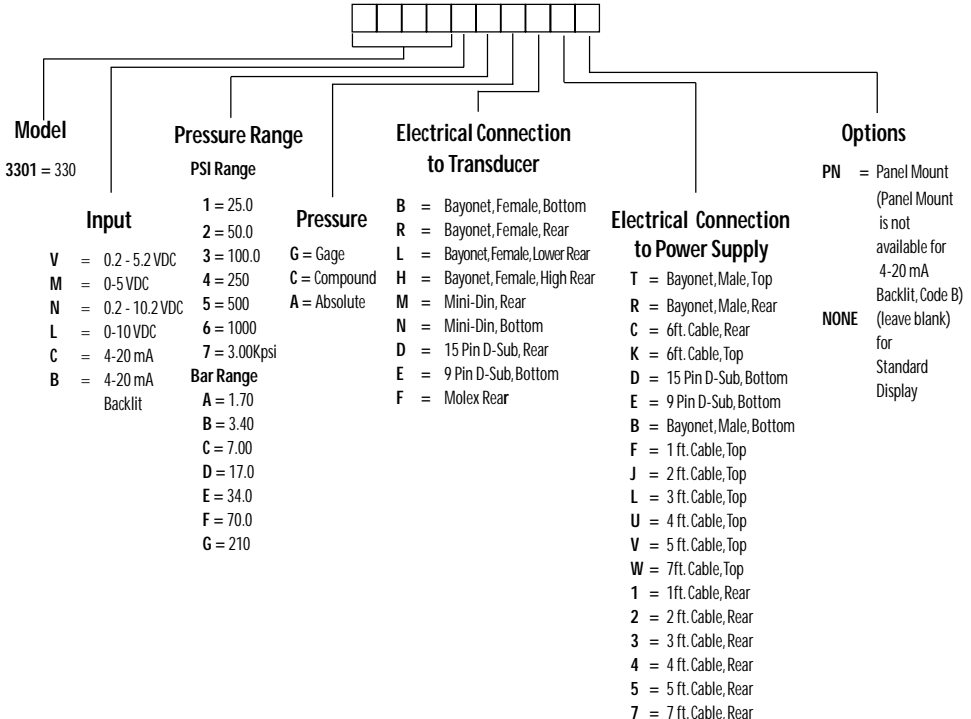

RETURNING PRODUCTS FOR REPAIR

Please contact a Setra application engineer (800-257-3872, 978-263-1400) before returning unit for repair to review information relative to your application. Many times only minor field adjustments may be necessary. When returning a product to Setra, the material should be carefully packaged and shipped prepaid to:

Setra Systems, Inc.
159 Swanson Road
Boxborough, MA 01719-1304
Attn: Repair Department

To assure prompt handling, please supply the following information and include it inside the package or returned material:

1. Name and phone number of person to contact.
2. Shipping and billing instructions.
3. Full description of the malfunction.
4. Identify any hazardous material used with product.

Notes: Please remove any pressure fittings and plumbing that you have installed and enclose any required mating electrical connectors and wiring diagrams.

Allow approximately 3 weeks after receipt at Setra for the repair and return of the unit. Non-warranty repairs will not be made without customer approval and a purchase order to cover repair charges.

Calibration Services

Setra maintains a complete calibration facility that is traceable to the National Institute of Standards & Technology (NIST). If you would like to recalibrate or recertify your Setra pressure transducers or, please call our Repair Department at 800-257-3872 (978-263-1400) for scheduling.

WARRANTY AND LIMITATION OF LIABILITY

SETRA warrants its products to be free from defects in materials and workmanship, subject to the following terms and conditions: Without charge, SETRA will repair or replace products found to be defective in materials or workmanship within the warranty period; provided that:

- a) the product has not been subjected to abuse, neglect, accident, incorrect wiring not our own, improper installation or servicing, or use in violation of instructions furnished by SETRA;
- b) the product has not been repaired or altered by anyone except SETRA or its authorized service agencies;
- c) the serial number or date code has not been removed, defaced, or otherwise changed; and
- d) examination discloses, in the judgment of SETRA, the defect in materials or workmanship developed under normal installation, use and service;
- e) SETRA is notified in advance of and the product is returned to SETRA transportation prepaid.

Unless otherwise specified in a manual or warranty card, or agreed to in writing and signed by a SETRA officer, SETRA pressure and acceleration products shall be warranted for one year from date of sale.

The foregoing warranty is in lieu of all warranties, express, implied or statutory, including but not limited to, any implied warranty of merchantability for a particular purpose.

SETRA's liability for breach of warranty is limited to repair or replacement, or if the goods cannot be repaired or replaced, to a refund of the purchase price. SETRA's liability for all other breaches is limited to a refund of the purchase price. In no instance shall SETRA be liable for incidental or consequential damages arising from a breach of warranty, or from the use or installation of its products.

No representative or person is authorized to give any warranty other than as set out above or to assume for SETRA any other liability in connection with the sale of its products.

159 Swanson Road, Boxborough, MA 01719-1304
Tel: 800-257-3872/978-263-1400, Fax 978-264-0292
Email: sales@setra.com, Web: www.setra.com

