



The Leader of RF  
and Sonic Level

For Assistance Call 1-800-527-6297  
Outside North America 1-215-674-1234

# Installation and Operating Instructions

Series 504-1200  
Ultrasonic VeriGAP™ Switch  
using 404-1200 and 404-1260  
Electronics

*(215) 674-1234 Outside North America  
1-800-527-6297 US and Canada  
<http://www.drexelbrook.com>  
e-mail: [Service@Drexelbrook.com](mailto:Service@Drexelbrook.com)*

AMETEK Drexelbrook makes no warranty of any kind with regard to the material contained in this manual, including, but not limited to, implied warranties or fitness for a particular purpose. Drexelbrook shall not be liable for errors contained herein or for incidental or consequential damages in connection with the performance or use of material.

Copyright 2001 AMETEK Drexelbrook

Series 504-1200  
Ultrasonic VeriGAP™ Switch  
using 404-1200 and 404-1260  
Electronics

 **AMETEK**®  
**DREXELBROOK**

205 Keith Valley Road Horsham, PA 19044

*An ISO 9001 Certified Company*

*US Sales*  
*24 Hour Service*  
*International*  
*Fax*  
*E-mail*  
*Web*

800-553-9092  
800-527-6297  
215-674-1234  
215-674-2731  
deinfo@drexelbrook.com  
www.drexelbrook.com



## Table of Contents

<b>SECTION 1 INTRODUCTION .....</b>	<b>1</b>
1.1 General Description.....	1
1.1.1 Verify Circuit.....	2
1.2 Model Numbering .....	3
<b>SECTION 2 INSTALLATION .....</b>	<b>4</b>
2.1 Unpacking .....	4
2.2 Mounting the Instrument .....	4
2.3 Wiring the Instrument.....	7
<b>SECTION 3 OPERATION .....</b>	<b>12</b>
3.1 Failsafe Selector .....	13
3.2 Verify™ Test .....	13
<b>SECTION 4 TROUBLESHOOTING .....</b>	<b>14</b>
<b>SECTION 5 SERVICE .....</b>	<b>15</b>
5.1 Factory Service Assistance .....	15
5.2 Equipment Return .....	15
5.3 Field Service .....	16
5.4 Customer Training.....	16
<b>SECTION 6 SPECIFICATIONS.....</b>	<b>17</b>
6.1 Electronics .....	17
6.2 Sensor .....	18
<b>APPENDIX A Drawings for FM &amp; CSA .....</b>	<b>19</b>

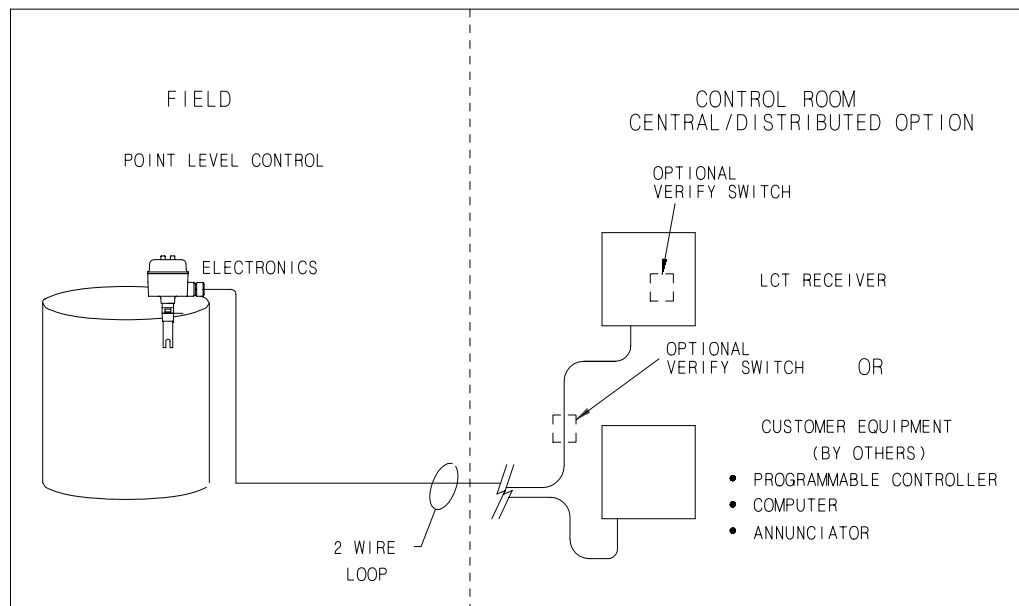


**SECTION 1  
INTRODUCTION**

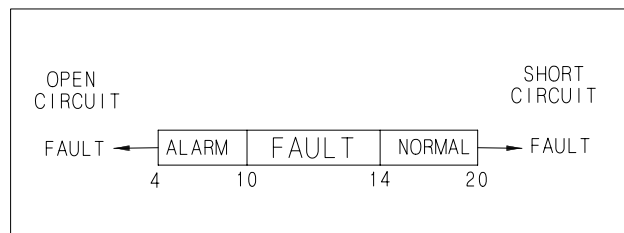
The instructions in this manual are for the Drexelbrook point level, two-wire ultrasonic VeriGAP™ switch, 504-1200 Series.

**1.1 General Description**

The 504-1200 Series VeriGAP™ is an integral assembly which senses liquid presence by ultrasonic techniques and is utilized to indicate and/or control the liquid at a predetermined level. The 504-1200 is a two-wire device. It draws current from a remote power supply over a pair of signal wires. This current is both the output signal and the operating power for the point level transmitter. It provides a 4-10 mA output when the material being measured reaches the sensing element point in a vessel, and provides a 14-20 mA output when the sensing element is uncovered. Figure 1-1 shows a typical system configuration. Figure 1-2 shows current output.



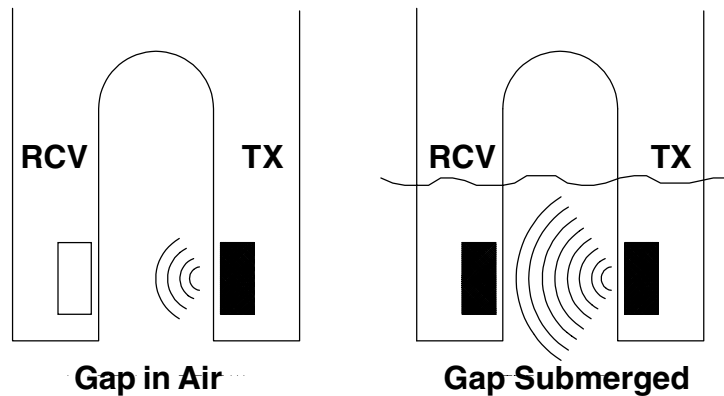
**Figure 1-1  
Typical System Configuration**



**Figure 1-2  
Current Output of a Two-Wire Transmitter**

### 1.1 General Description (continued)

A high frequency acoustic signal is transmitted through the sensor gap when liquid is present. When liquid is not present, no signal transmission occurs. See Figure 1-3. When a signal is received, an electronic circuit produces a relay output.



*Figure 1-3  
Gap Switch Operation*

The ultrasonic sensor does not contain moving components. It is not affected by electrical or physical parameters of the process material and will operate over a wide temperature range. These characteristics make the 504-1200 a very reliable and economical solution to industrial liquid level control operations. The ultrasonic sensor does not contain moving components and is not affected by electrical or physical parameters of the liquid. These characteristics make the VeriGAP a very reliable and economical solution to industrial liquid level control operations.

Inherent benefits of the VeriGAP include high reliability and minimum maintenance, as they are not affected by variations in liquid viscosity, density, pressure, temperature, or electrical properties. For applications where the sensor will be coated or the liquid is aerated, consult the factory at 1-800-527-6297.

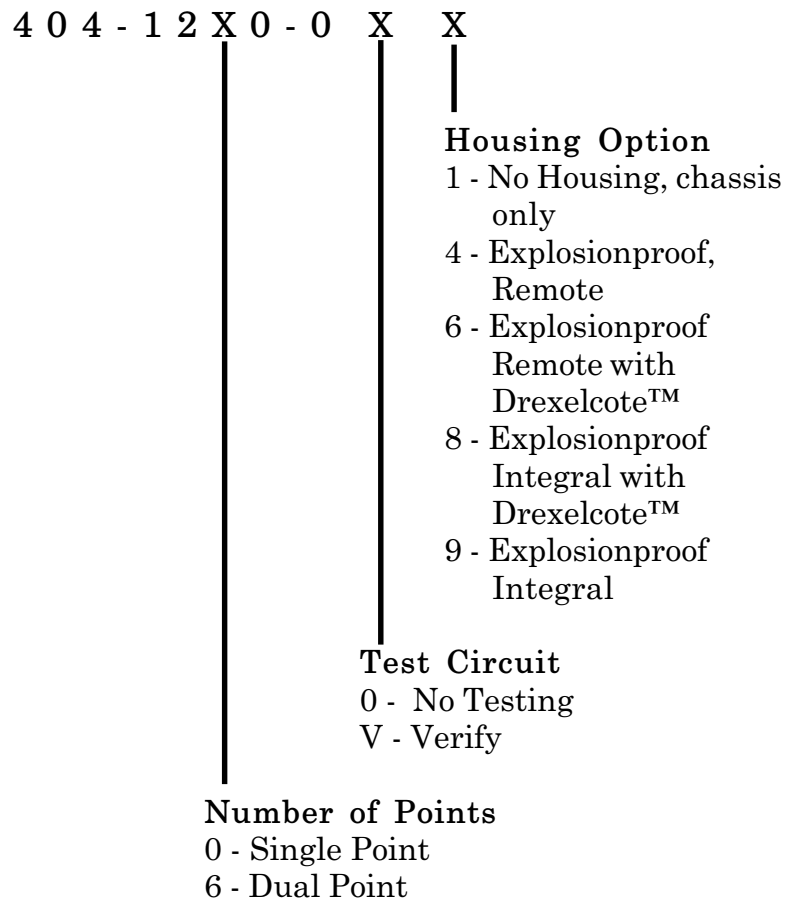
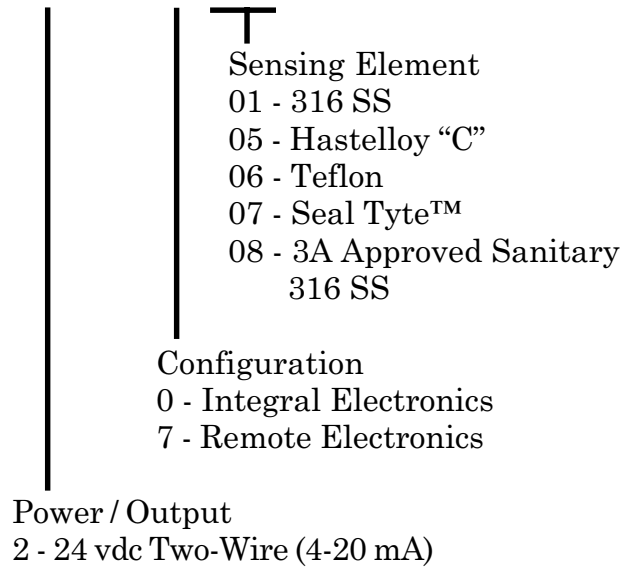
#### 1.1.1 Verify™ Circuit

As an option, the ultrasonic two-wire Verify™ circuit is used in conjunction with the VeriGAP for pushbutton verification that the entire control system is functioning properly. This option is used with High Level Fail-safe devices only. It simulates a high level at the sensing element to meet spill prevention regulations and recommended practices. **This test may also be used for ISO 9000 validation of your high level alarms and spill prevention systems.**

An optional Drexelbrook Point Level Receiver provides power to the VeriGAP and monitors its current draw. Relays are activated on change of level states.

## 1.2 Model Numbering

5 0 4 - 1 2 0 0 - X X X VeriGAP™ Switch



**SECTION 2  
INSTALLATION**

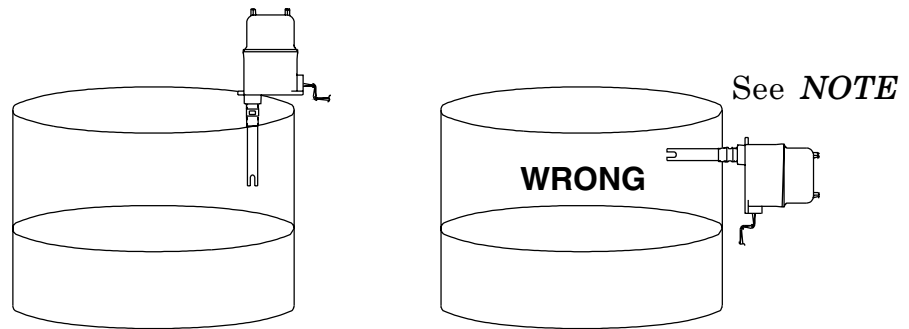
**2.1 Unpacking**

Carefully remove the contents of the shipping carton and check each item against the packing list before destroying any packing material. If there is any shortage or damage, report it immediately to the factory (1-800-527-6297).

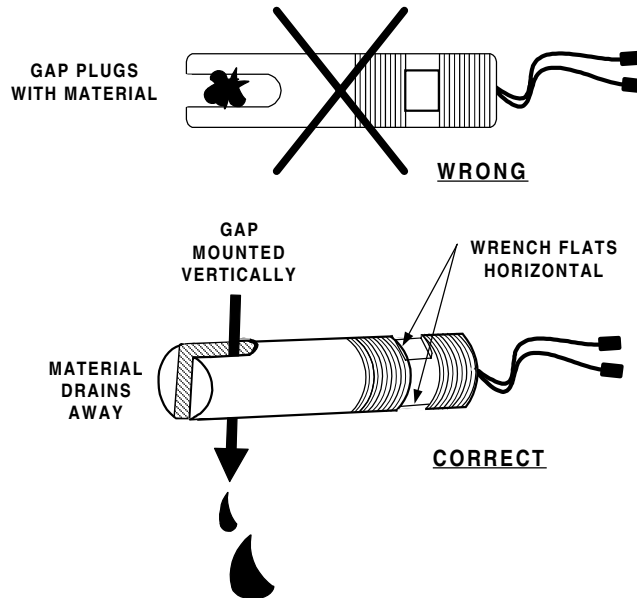
**2.2 Mounting the Instrument**

The 504-1200 electronic unit was designed for field mounting, but it should be mounted in a location as free as possible from vibration, corrosive atmospheres, and any possibility of mechanical damage. For convenience at start-up, place the instrument in a reasonably accessible location. Ambient temperatures should be between -40°F and 160°F (-40°C to 70°C).

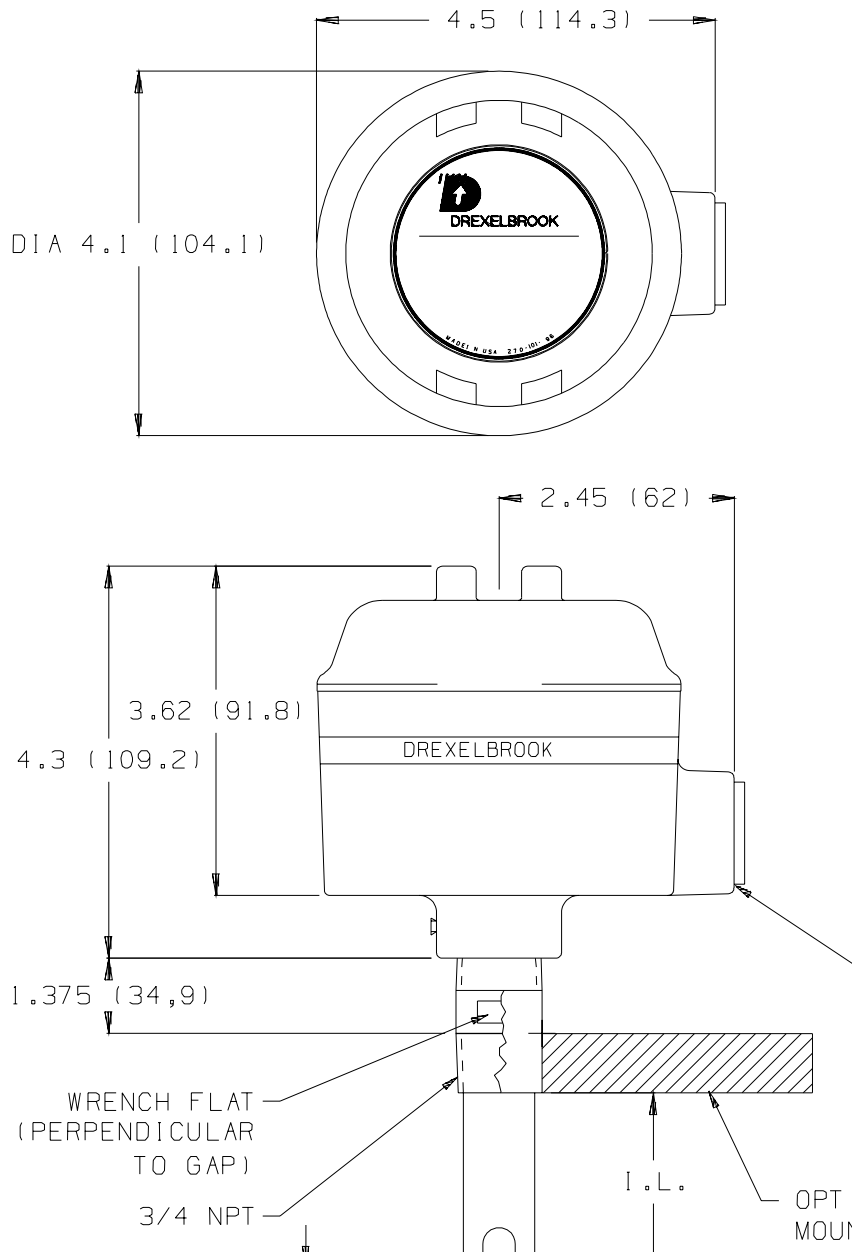
The 504-1200 VeriGAP™ switches can be mounted in any orientation vertically.



**NOTE**  
If the unit is mounted horizontally, rotate the sensor so that the electrical hub is down and the sensor slot is vertical. This allows any product buildup on the sensor to fall free. Note orientation of wrench flats relative to the gap.

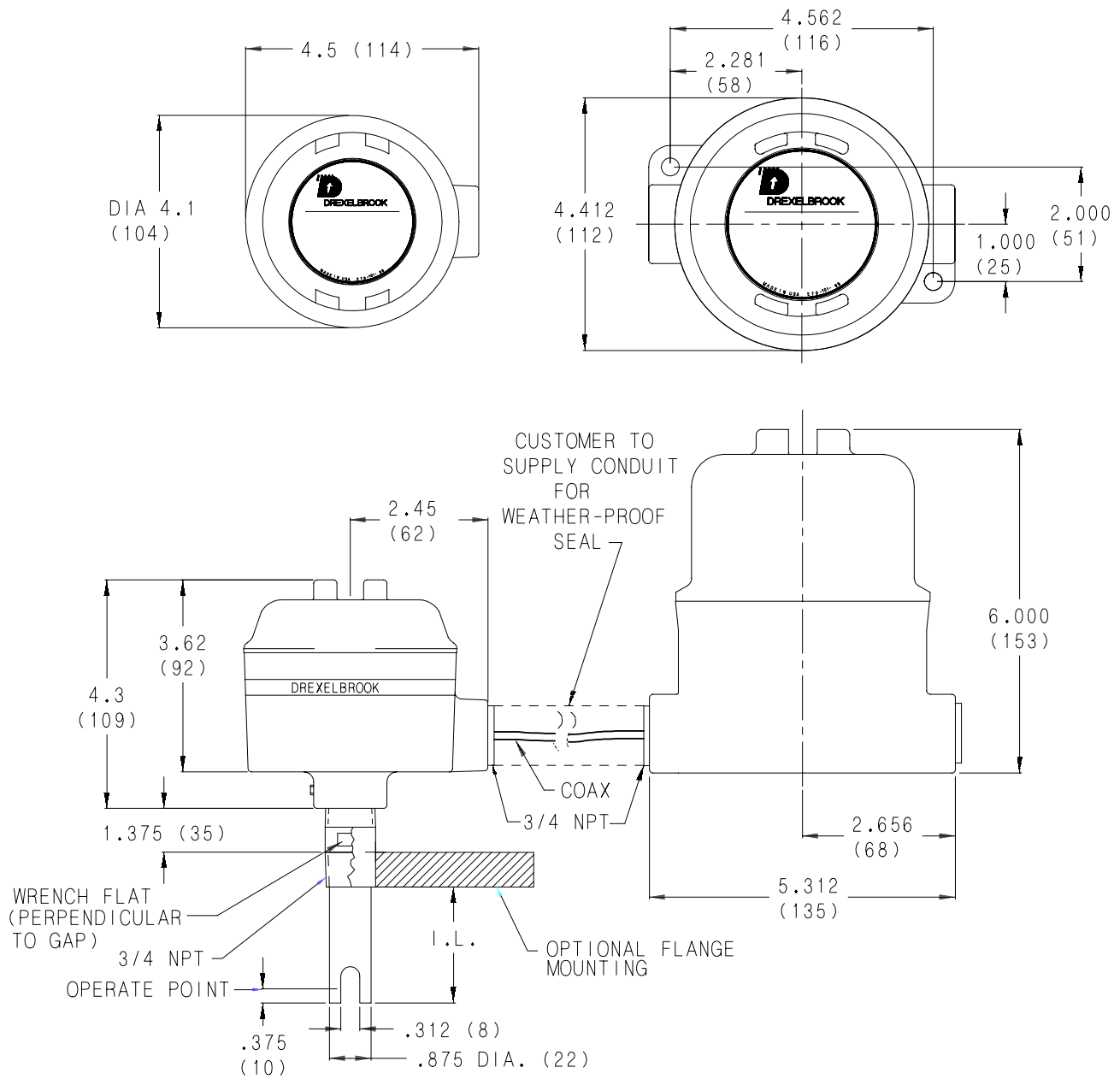


*Figure 2-1  
Mounting Orientation*



All dimensions in inches (mm)

*Figure 2-2*  
*Mounting Dimensions, Integral Unit*



All dimensions in inches (mm)

**Figure 2-3**  
**Mounting Dimensions, Remote Mounting**

### 2.3 Wiring the Instrument

#### *CAUTION*

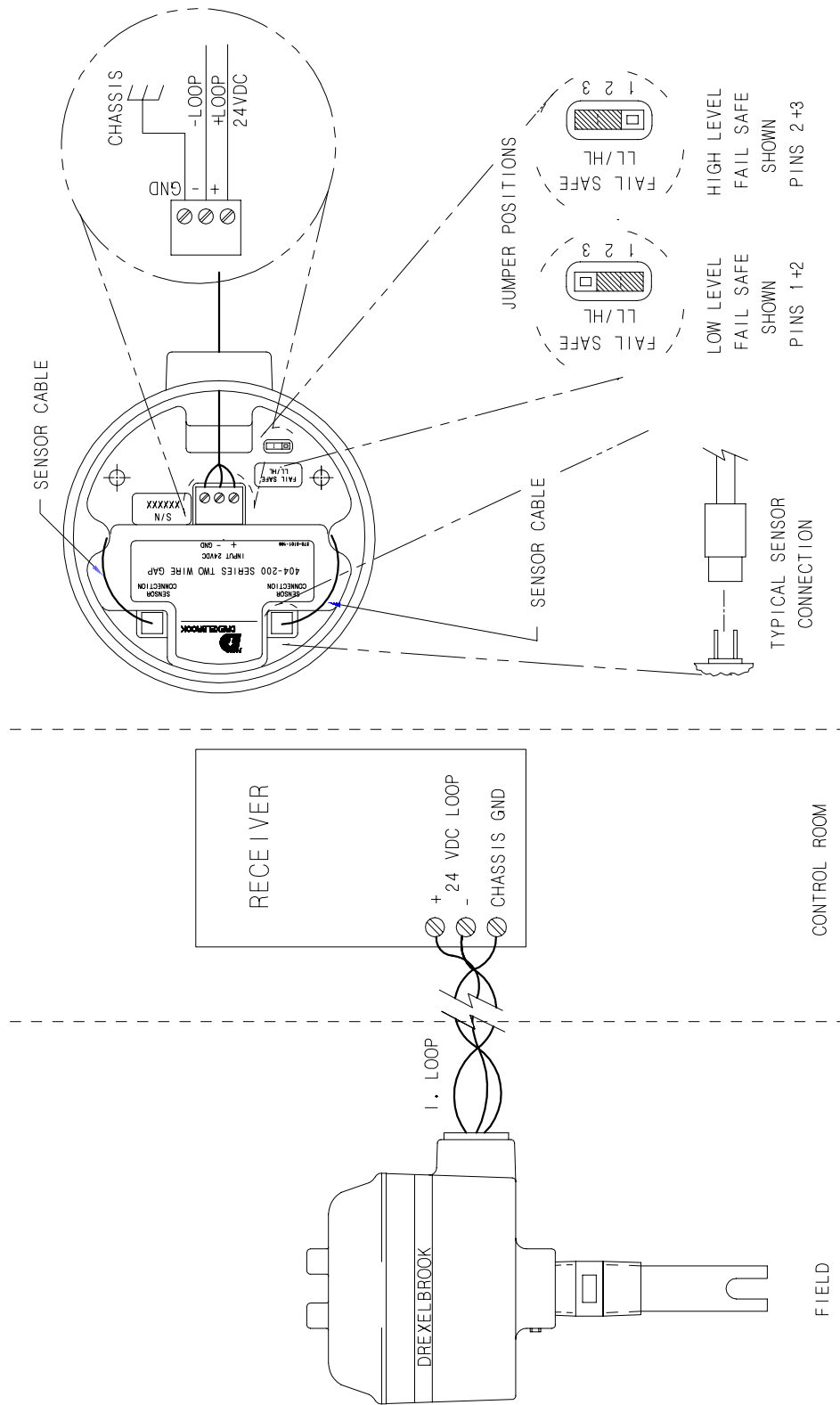
Ensure that all wiring, electrical fittings and conduit connections conform to your local electrical codes for the location and environment of use. If the 504-1200 Gap Switch is located in a hazardous environment, do not open the enclosure cover or make/break any electrical connections without first disconnecting electrical power at the source unless an intrinsically safe power supply is used.

Use the following procedure to wire the 504-1200 Switch:

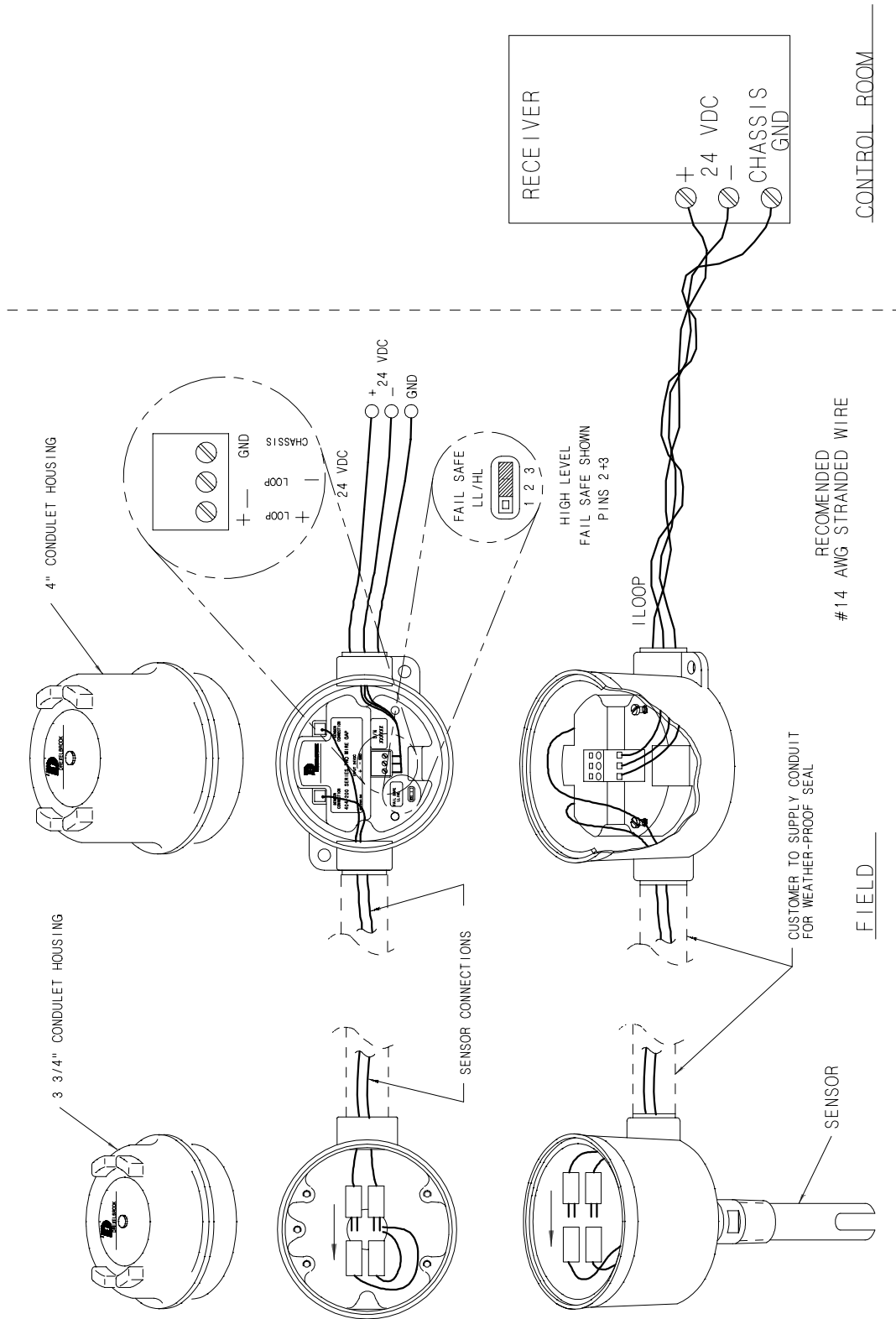
1. Ensure that the power is off.
2. Remove the cover.
3. Make all electrical connections to the 504-1200 VeriGAP™ Switch per the wiring diagram shown in Figure 2-4 (Integral Single Gap), Figure 2-5 (Remote Single Gap), Figure 2-6 (Integral Dual Mount). Use 14-gauge or smaller wiring (stranded wiring is preferred). All connections are made on the terminal strip.
4. If shielded wire is used, only ground one end. The other end is left floating. This wiring practice prevents ground loop problems.
5. The PC board mounting screws can be removed to allow movement of the PC board during wiring.
6. After connections are secured and dressed, re-insert the electronic unit and close the enclosure cover.
7. Review Checklist:
  - Wiring correct?
  - Proper input voltage used?
  - Proper relay state at the receiver (relays will be in the alarm condition)?
8. Turn power on.

#### *NOTES*

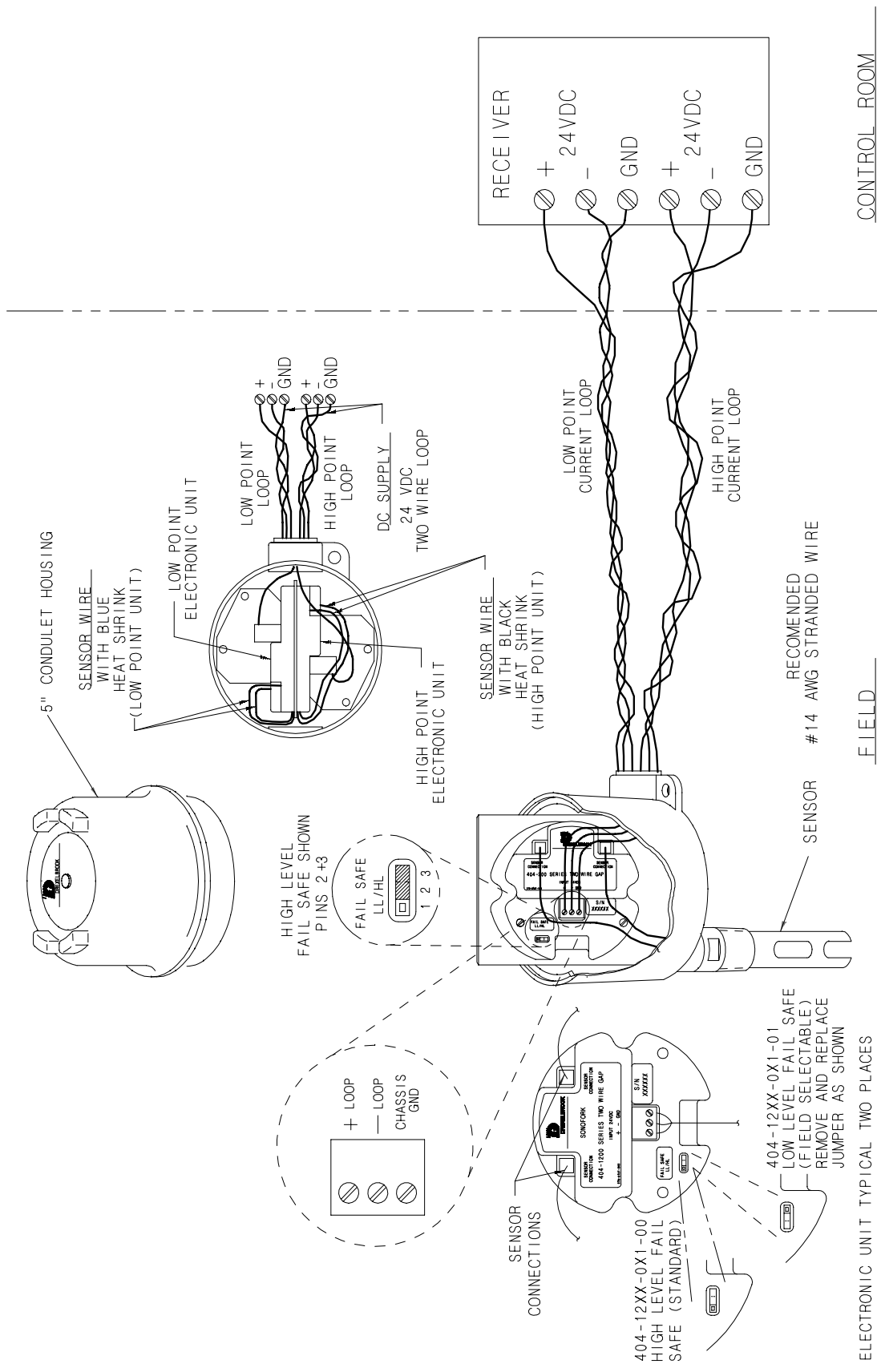
- Make sure that the 115 Vac supply is clean and free of noise.
- Do not supply power to the VeriGAP that originates at a variable frequency drive motor supply.
- Do not run relay wires or supply wires in same conduit as variable frequency drive wiring.



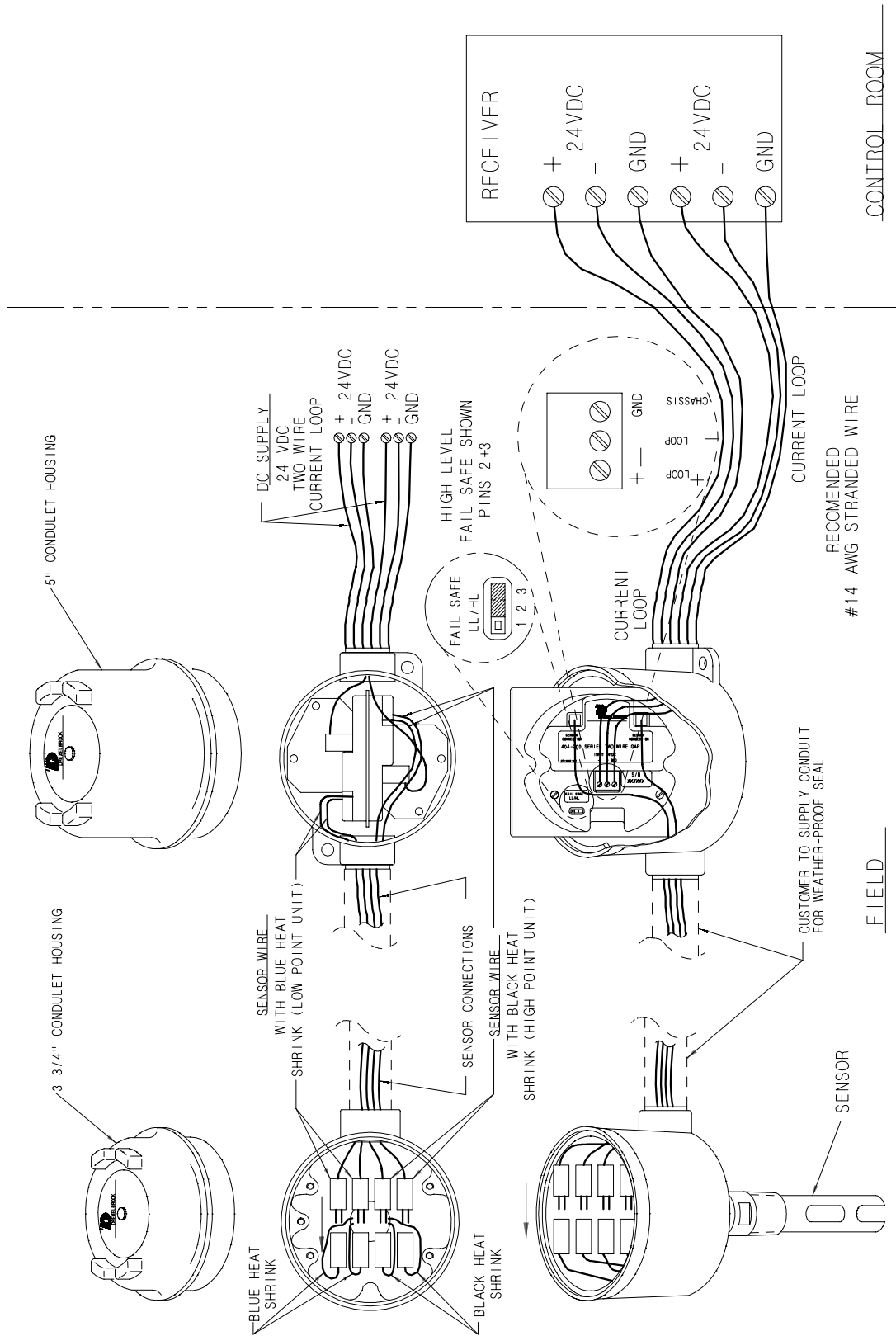
**Figure 2-4**  
**Wiring Diagram**  
**Integral Single Gap**



**Figure 2-5**  
**Wiring Diagram**  
**Remote Single Gap**



**Figure 2-6**  
**Wiring Diagram**  
**Integral Dual Gap**



**Figure 2-7**  
**Mounting Dimensions**  
**Remote Dual Gap**

**SECTION 3  
OPERATION**

The VeriGAP switch operates successfully upon applying power to the unit. No further calibration or adjustments are necessary.

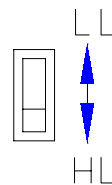
**3.1 Failsafe  
Selector**

There is one operating switch on the instrument for failsafe selection.

Failsafe describes the level condition that causes the output signal to change states.

- High Level Failsafe (HLFS) means the output signal will change to the alarm state under high level conditions (indicating high level upon loss of power).
- Low Level Failsafe (LLFS) means the output signal will change to the alarm state under low level conditions (indicating low level upon loss of power).
- The instrument is supplied in the failsafe mode that is requested when the order is placed (HLFS, if not specified).
- The failsafe is field selectable by changing the link on the top of the unit. See Figure 3-1.

## FAIL SAFE SWITCH



*Figure 3-1  
Failsafe Switch Settings*

### 3.2 Verify™ Test (for switches with Verify option)

The Verify test feature performs a confidence test of the system by duplicating the same signal as a high-level alarm condition. Simulating a high level with the Verify test feature:

- confirms that the system is set up correctly for ISO 9000 purposes.
- checks the integrity and continuity of wiring connections.
- verifies that the sensing element is working properly.
- checks the connection to other control devices.

By pressing the Verify switch on the 401-10-210 switch module (or on any optional LCT receiver), a momentary short circuit is created on the signal wires. The short circuit is recognized by the pulse module as a negative-going pulse. (The pulse module requires a minimum voltage drop of 6.0 volts.)

The pulse module simulates a high level alarm condition in the vessel. If the system is functioning properly, the Verify pulse forces the transmitter to change its output state from normal to alarm.

If there are *any* faults or malfunctions associated with the switch, *no* alarm signal is generated when the switch is activated.

**SECTION 4  
TROUBLESHOOTING**

The 504-1200 Ultrasonic VeriGAP™ Switch is a solid-state device with no moving parts. It requires no maintenance or adjustments. The units are designed to give years of unattended service.

A spare electronic chassis is recommended for every 10 units. In the event of a failed unit, this will prevent the interruption of a critical application while the unit is returned to the factory for repair.

In applications where liquids/products can coat or build up on the sensor tip over a period of time, it is recommended to use the Drexelbrook RF Admittance Point Level switches, which are not affected by coatings.

Proper operation of the gap switch can be verified by dipping the gap assembly in a small container of liquid (e.g. water). Connect a milliammeter in series with the current loop and monitor the loop current. With the unit switched to high level failsafe and the sensing element in liquid, the loop current should be 4-10 mA. If this does not occur, remove the equipment from the process for visual inspection.

- Check to see that the gap is not plugged by process material.
- Clean if required.
- Repeat the dip test.
- If no change occurs in loop current, the instrument has failed.

The gap assembly is removed by disconnecting the two coax cables from the electronics module.

- Gently pull the quick disconnect connectors at the end of the coax wires out of the electronics module circuit card.
- Loosen the set screw in the blue cast housing and unscrew the gap assembly from cast housing.
- If spare parts are available find out whether the problem is caused by a defective gap assembly or by a defective electronics module. This is done by substituting a known good gap assembly or electronics module.

**SECTION 5**  
**FACTORY AND**  
**FIELD SERVICE**

If you are experiencing difficulty with your Drexelbrook equipment and attempts to locate the problem have failed:

- contact your local Drexelbrook representative,
- call the Service department toll-free at 1-800-527-6297 (in US and Canada) or 1-215-674-1234 (International),
- fax the following information to the Service department at 1-215-674-5117.

**5.1 Factory**  
**Service**  
**Assistance**

To expedite assistance, please provide the following information:

Instrument Model Number \_\_\_\_\_

Sensing Element Model Number and Length \_\_\_\_\_  
 \_\_\_\_\_

Coax Cable Length (remote systems) \_\_\_\_\_

Original Purchase Order Number \_\_\_\_\_

Material being measured \_\_\_\_\_

Temperature \_\_\_\_\_

Pressure \_\_\_\_\_

Agitation \_\_\_\_\_

Brief description of the problem \_\_\_\_\_  
 \_\_\_\_\_

Checkout procedures that have failed \_\_\_\_\_  
 \_\_\_\_\_  
 \_\_\_\_\_

**5.2 Equipment**  
**Return**

In order to provide the best service, any equipment being returned for repair or credit must be pre-approved by the factory.

In many applications, sensing elements are exposed to hazardous materials.

- OSHA mandates that our employees be informed and protected from hazardous chemicals.
- Material Safety Data Sheets (MSDS) listing the hazardous materials that the sensing element has been exposed to **must** accompany any repair.
- It is your responsibility to fully disclose all chemicals and decontaminate the sensing element.

**5.2 Equipment  
Return  
(cont.)**

To obtain a return authorization (RA#), contact the Service department at 1-800-527-6297 (US and Canada) or 1-215-674-1234 (International). Please provide the following information:

Model Number of Return Equipment \_\_\_\_\_

Serial Number \_\_\_\_\_

Original Purchase Order Number \_\_\_\_\_

Process Materials that equipment has been exposed to \_\_\_\_\_

MSDS sheets for any hazardous materials

Billing Address \_\_\_\_\_

Shipping Address \_\_\_\_\_

Purchase Order Number for Repairs \_\_\_\_\_

*Please include a purchase order even if the repair is under warranty. If repair is covered under warranty, you will not be charged.*

Ship equipment freight prepaid to:  
AMETEK DREXELBROOK  
205 KEITH VALLEY ROAD  
HORSHAM, PA 19044  
COD shipments will not be accepted.

**5.3 Field  
Service**

Trained field service personnel are available on a time-plus-expense basis to assist in start-ups, diagnosing difficult application problems, or in-plant training of personnel. Preventative Maintenance and Calibration Certification service contracts are also available to maintain plant efficiency. Contact the Service department for further information.

**5.4 Customer  
Training**

Instrument Training Seminars for customers are conducted at the factory. These sessions, guided by Drexelbrook engineers and specialists, provide detailed information on all aspects of level measurement, including theory and practice of instrument operation. Contact the Training Department for further information.

**SECTION 6  
SPECIFICATIONS****6.1 Electronics***—Power Requirements*

13-30 Vdc

*—Power Consumption*

.5 watt at 20 mA

*—Ambient Temperature*

-40°F to 160°F

*—Repeatability*

1/16 inch

*—Response Time*

50 microseconds

*—Fail Safe*

High Level or Low Level (field-selectable)

*—Housing*

NEMA 1 to 4X, 5 and 12

FM Approved Explosionproof

Intrinsically Safe

**6.2 Sensing  
Element***—Insertion Lengths*

2, 6, 12, 18, or 24 inches standard (other lengths available)

*—Wetted Materials*

Standard 316 SS

Optional Alloy 20, Hastelloy “C”, Teflon

(Consult factory for availability of other materials)

*—Mounting*

Metallic Sensors:       $\frac{3}{4}$ -inch NPT standard,  
flange mounting available.

Teflon Sensors:      1-inch NPT standard,  
threaded flange mounting  
available.

Seal Tyte™ Sensors:      Flange mounting only,  
1-inch minimum flange

*—Gap*

Single gap standard (404-1200)

Dual gap available (404-1260)

*—Process Temperature*

-40°F to 250°F

*—Process Pressure*

1000 psi maximum, metallic sensors

50 psi maximum, Teflon sensors

**APPENDIX A**  
**APPROVAL DRAWINGS**

The following pages provide the FM and CSA approved control drawings

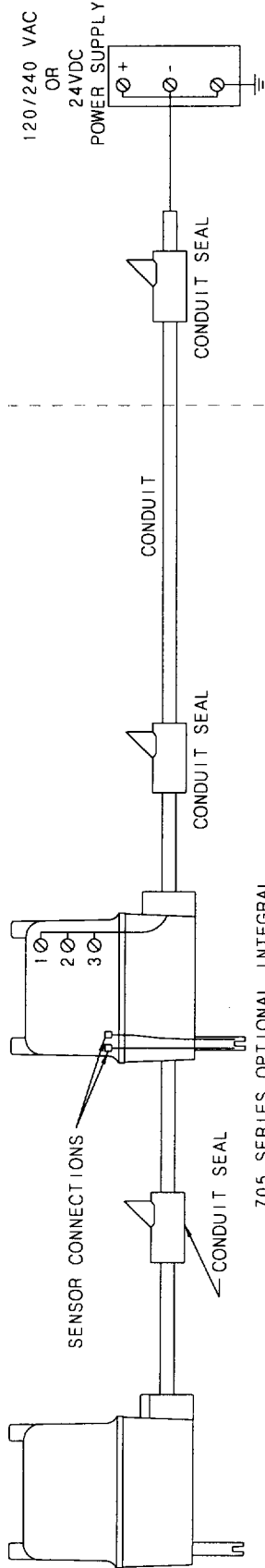
420-4-24-CD



\*NO CHANGE IN PART OR VENDOR OF PART ALLOWED WITHOUT PRIOR APPROVAL OF FM.\*

**404-1000, 1100, 1300 SERIES  
EXPLOSIONPROOF INSTALLATION**

- 404-1000/1300  
120/240 VAC  
1 ♂ — L1 +  
2 ♂ — L2 -  
3 ♂ — GND
- 404-1100  
24 VDC  
1 ♂ — +  
2 ♂ — -  
3 ♂ — GND



**705 SERIES OPTIONAL INTEGRAL  
AND REMOTE ULTRASONIC SENSOR**

**FM AND CSA APPROVED ELECTRONICS**

404-1ab0-cde-0f

- a = 0.1.3 SUPPLY VOLTAGE
  - b = 0.6 SINGLE OR DUAL POINT
  - c = AGENCY F=FM C=CSA
  - d = 0.1 OPTIONS
  - e = 1.2.3.4.6.8.9.C.F HOUSING WHEN e=2.4 OR 3.6 EXPLOSIONPROOF ENCLOSURE 285-0001-414 285-0001-415 REQUIRED FOR REMOTE SENSOR INSTALLATION
  - f = 0.1.2 FAIL SAFE
- NOTE: WHEN e = 1 CHASSIS MUST BE MOUNTED IN FM OR CSA APPROVED EXPF. HOUSING.  
DUAL POINT USES 5" HOUSING.  
ALL OTHERS 4"

- NOTES:
1. FOR EXPLOSIONPROOF INSTALLATIONS CONDUIT SEALS MUST BE WITHIN 2" OF TRANSMITTER HOUSING.
  2. INSTALL PER NEC OR CEC.
  3. FOR 404-1060 CONNECTIONS SEE DRAWING 504-1600-001-CD1.
  4. REFER TO FOLLOWING DRAWINGS FOR RELAY CONNECTIONS:  
504-1000-001-CD1, 504-1100-001-CD1,  
504-1600-001-CD1, 504-1600-001-CD2.

CLASS I, II, III, DIVISION 1, GROUP A, B, C, D, E, F, G

NON-HAZARDOUS AREA

CERTIFIED	by	5	9-01-202	DHP	1/24/02	COPYRIGHT	2001
PO #		4	6-00-201	THP	6-23-00	AMETEK DREXELBROOK	
ENG		3	6-96-212	OJM	8-22-97	SCALE	NONE
USER		2	5-95-212	OJM	5-13-96	UNLESS OTHERWISE STATED ALL DIMENSIONS IN INCHES (MM)	
		1	12-94-204	THP	5-4-95	DR.	CDW
ISS.	EDO/DSR NO.	APP'D	DATE	CK.	JTB	3-6-02	
DE #							

**AMETEK®**  
**DREXELBROOK**

205 KEITH VALLEY RD  
MORSHAM, PA 18044-9986  
215-674-1234  
FAX 215-674-2731

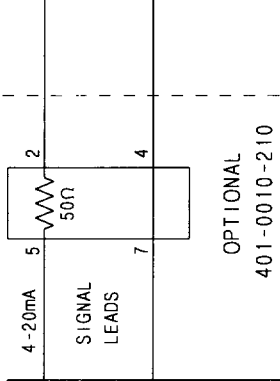
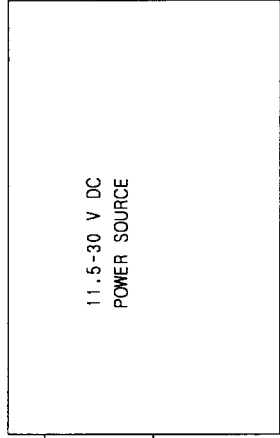
FM AND CSA CONTROL DRAWING  
FOR ULTRASONIC  
POINT LEVEL SENSOR  
TRANSMITTERS VeriGAP™

420-0004-024-CD

SHT. 2 OF 5  
ISS. OF 5

DIV. 2 LOOP. 404-1200 SERIES NO BARRIERS

SAFE AREA



SUITABLE FOR  
CLASS I GROUPS A,B,C,D. AND  
CLASS II GROUPS F,G AND  
CLASS III.

WARNING FOR ALL SHEETS:

- EQUIPMENT CONNECTED TO SIGNAL LEADS MUST NOT USE OR GENERATE MORE THAN 250V MAX.
- SEE SHEET 3 FOR CLASS II AND CLASS III HOUSING NOTE.

MODEL NUMBERS OF APPROVED TRANSMITTERS  
SHOWN ON SHEETS 3-5:

TRANSMITTERS

- 404-120a-Fbc-0d  
a = 0 TIME DELAY  
b = 0 OR V OPTIONS  
c = 1.7.A HOUSING  
d = 0.1 FAIL SAFE

NOTE:

WHEN c = 1 CHASSIS MUST BE MOUNTED IN APPROVED HOUSING.

DIVISION 2 AREA

SENSOR

- 705-efgh-ijk-l  
e = BLANK OR 0  
f = BLANK OR 0  
g = BLANK OR 0  
h = 1.2 TEMPERATURE  
i = BLANK,3.6. CONSTRUCTION  
j = BLANK OR 0  
k = 1.3.5.6. MATERIALS  
l = 14 CHARACTER EXPANDED NUMBERING SYSTEM.  
DOES NOT AFFECT SAFETY.

CERTIFIED	by	5	9-01-202	12/102	COPYRIGHT 2001
PO #		4	6-00-201	THP	6-23-00
ENG		3	6-96-212	OJM	8-22-97
USER		2	5-95-212	OJM	5-13-96
DE #		1	12-94-204	THP	5-4-95
ISS.	EDO/DSR NO.	APP'D	DATE	DR.	CDW
				CK.	JJS 3-6-02



205 KEITH VALLEY RD  
HORSHAM, PA 19044-9886

215-674-1234  
FAX 215-674-2731

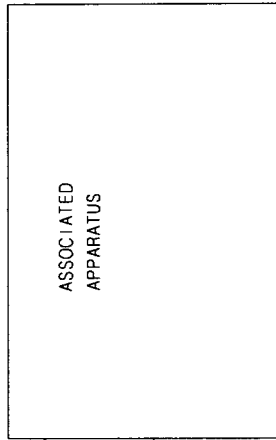
FM CONTROL DRAWING FOR  
ULTRASONIC  
POINT LEVEL TRANSMITTER

420-0004-024-CD

SHT. 3 OF 5

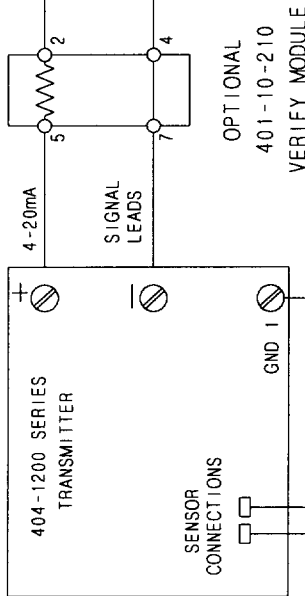
404-1200 SERIES ENTITY APPROVAL

SAFE AREA



NOTES ON ASSOCIATED APPARATUS

1. MAY BE IN DIV. 2 LOCATION IF SO APPROVED.
2. CABLE CAPACITANCE AND INDUCTANCE (C = 60pF/FT. AND L = 0.2uH/FT. MAY BE USED) PLUS TRANSMITTER C<sub>i</sub> AND L<sub>i</sub> MUST NOT EXCEED C<sub>a</sub> AND L<sub>a</sub> OF ASSOCIATED APPARATUS.
3. MUST BE INSTALLED PER MANUFACTURER'S INSTRUCTIONS.
4. MUST NOT BE CONNECTED IN PARALLEL.
5. MUST BE INSTALLED IN ACCORDANCE WITH NEC IN AN ENCLOSURE MEETING THE REQUIREMENTS OF ANS1/ISA S82.



DIVISION 1 AREA

SENSING ELEMENTS AND CABLE ARE INTRINSICALLY SAFE FOR CLASS I GROUPS A, B, C, D, CLASS II GROUPS E, F, G, CLASS III.

TRANSMITTER ENTITY PARAMETERS

V<sub>max</sub> = 35 V  
 I<sub>max</sub> = 140 mA  
 C<sub>i</sub> = 0 uF  
 L<sub>i</sub> = 0 mH

CLASS II AND CLASS III HOUSING NOTE:

USE ONLY APPROVED DUST IGNITIONPROOF HOUSINGS, WITH DUST TIGHT CABLE FITTINGS OR THREADED CONDUIT, FOR ENVIRONMENTAL PROTECTION IN CLASS II DIV. 1 AND 2 APPLICABLE GROUPS E, F, G AND CLASS III DIV. 1 AND 2.

CERTIFIED	by	5	9-01-202	DRP	1/28/02	COPYRIGHT 2001
PO #		4	6-00-201	THP	6-23-00	AMETEK DREXELBROOK
ENG		3	6-96-212	OJM	8-22-97	SCALE NONE
USER		2	5-95-212	OJM	5-13-96	UNLESS OTHERWISE STATED ALL DIMENSIONS IN INCHES (MM)
DE #		1	12-94-204	THP	5-4-95	DR. CDW
ISS.	EDO/DSR NO.	APP'D	DATE	CK.	JES 2-6-02	

**AMETEK®**  
**DREXELBROOK**

205 KEITH VALLEY RD  
 HORSHAM, PA 19044-9986

215-674-1234  
 FAX 215-674-2731

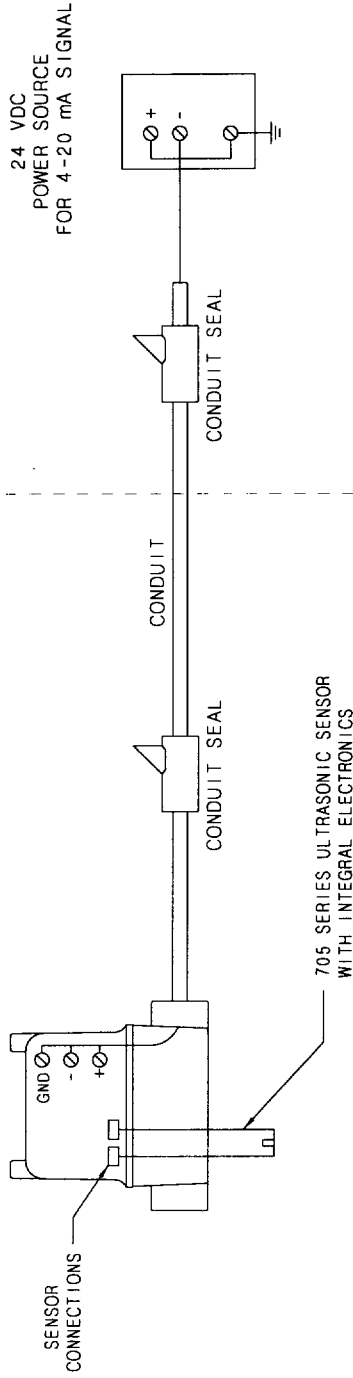
FM CONTROL DRAWING FOR  
 ULTRASONIC  
 POINT LEVEL TRANSMITTER

420-0004-024-CD

SHT. 4 OF 5

\*NO CHANGE IN PART OR VENDOR OF PART ALLOWED WITHOUT PRIOR APPROVAL OF FM.\*

EXPLOSIONPROOF 404-1200 SERIES INSTALLATION



MAXIMUM  
NON-HAZARDOUS AREA  
VOLTAGE MUST NOT  
EXCEED 250 Vrms.

NON-HAZARDOUS AREA

FM CONTROL DRAWING FOR  
ULTRASONIC  
POINT LEVEL TRANSMITTER

420-0004-024-CD  
SHT. 5 OF 5



215-674-1234  
FAX 215-674-2731

205 KEITH VALLEY RD  
HONSHAM, PA 19044-9966

- NOTES:
1. FOR EXPLOSIONPROOF INSTALLATIONS CONDUIT SEALS MUST BE WITHIN 2 INCHES OF TRANSMITTER HOUSING.
  2. EXPLOSIONPROOF INSTALLATIONS MUST COMPLY WITH NEC.

CLASS I.I.I.I.I.I.I.I. DIVISION 1. GROUP A.B.C.D.E.F.G

CERTIFIED	by	1/24/02	COPYRIGHT	2001
PO #	THP	6-23-00	AMETEK DREXELBROOK	
ENG	OJM	8-22-97	SCALE NONE	
USER	OJM	5-13-96	UNLESS OTHERWISE STATED	
	THP	5-4-95	ALL DIMENSIONS IN INCHES (MM)	
ISS.	EDO/DSR NO.	APP'D	DATE	DR.
DE #				CDW



**AMETEK<sup>®</sup>**  
**DREXELBROOK**

*An ISO 9001 Certified Company*

205 Keith Valley Road Horsham, PA 19044

*US Sales* 800-553-9092

*24 Hour Service* 800-527-6297

*International* 215-674-1234

*Fax* 215-674-2731

*E-mail* [deinfo@drexelbrook.com](mailto:deinfo@drexelbrook.com)

*Web* [www.drexelbrook.com](http://www.drexelbrook.com)