

Model 720 Absolute Capacitance Manometer

Available in Standard Torr, kPa and mbar Vacuum Ranges



Setra's Model 720 is an accurate, low cost pressure manometer for vacuum applications. The 720 is designed to be used with pressure media compatible with Inconel®. The all-welded construction eliminates stability issues inherent in other designs due to frictional contact between dissimilar metals.

Setra's patented variable capacitance sensor design combines the ultimate in simplicity, with high accuracy and superior thermal stability. It features an Inconel® diaphragm and an insulated electrode, which forms a

variable capacitor. As pressure (vacuum) increases or decreases, the capacitance changes. This capacitance is detected and converted to a fully conditioned linear voltage output signal.

The Model 720 is offered with a variety of vacuum pressure fittings. Its rugged design, high overpressure capability (see table), and wide operating temperature make the Model 720 ideal for the most demanding applications.

Pressure Ranges and Proof Pressure

Range	Proof
Torr	psia
0-10	45
0-20	45
0-100	45
0-1000	45

Range	Proof
kPa	kPa
0-1	300
0-2	300
0-10	300
0-100	300

Range	Proof
mbar	mbar
0-10	3000
0-20	3000
0-100	3000
0-1000	3000

Inconel is a registered trademark of Special Metals, Inc. Huntington, WV, USA.

NOTE: Setra quality standards are based on ANSI-Z540-1. The calibration of this product is NIST traceable.

U.S. Patent nos. 4054833

Applications

- Semiconductor Applications
- Absorption Chillers
- Lasers
- Autoclaves
- Vacuum Packaging
- Freeze Drying
- Vacuum Distillation

Features

- Wide Compensated Operating Temperature
- CE Mark Compliance
- Fully Protected Against Miswiring

*When it comes to a product to rely on - choose the Model 720.
When it comes to a company to trust - choose Setra.*



Visit Setra Online:
<http://www.setra.com>

setra

800-257-3872

Model 720 Specifications

Accuracy Data

Accuracy RSS*	±0.5% Reading
	±0.25% Reading (optional)
Resolution	Infinite, limited only by output noise level (0.01% FS)

Thermal Effects**

Compensated Range °C (°F)	0 to +50 (+32 to +122)
Zero Shift	±0.005% FS/°C (±0.01% FS/°F)
Span Shift	±0.027% RDG/°C
Long Term Stability	±0.5% FS/YR

Response Time 20 milliseconds

*RSS of Non-Linearity, Non-Repeatability and Hysteresis.

**Units calibrated at nominal 70°F. Maximum thermal error computed from this datum.

Environmental Data

Temperature	
Operating °C (°F)	-20 to +80 (-4 to +176)
Storage °C (°F)	-40 to +125 (-40 to +257)
Shock	50 g Operating

*Operating temperature limits of the electronics only. Pressure media temperatures may be considerably higher or lower.

Physical Description

Case	Stainless Steel
Electrical Connection	Screw Terminal or 9 Pin D-Sub
Pressure Fittings	See Ordering Information
Wetted Material	Inconel®
Cavity Volume	<6.2 cc
Weight (approx)	137 g

Specifications subject to change without notice.

Electrical Data (Voltage)

Circuit	3-Wire
Excitation/Output*	14 to 30 VDC for 0-10 VDC** 9 to 30 VDC for 0-5 VDC**
Power Consumption	<200 mW
Output Impedance	<1 ohm
CE Compliance	89/336/EEC for Heavy Industrial

*Calibrated into a 50K ohm load, operable into a 5000 ohm load or greater.

**Zero output factory set to within ±25mV (for 5 VDC output) or ±50mV (for 10 VDC output).

**Span (Full Scale) output factory set to within ±25mV (for 5 VDC output) or ±50mV (for 10 VDC output).

Pressure Media

Gases or liquids compatible with Inconel®. Inconel® wetted material is for 0.5" tube option only. Other fitting options will add Stainless Steel.

Outline Drawings

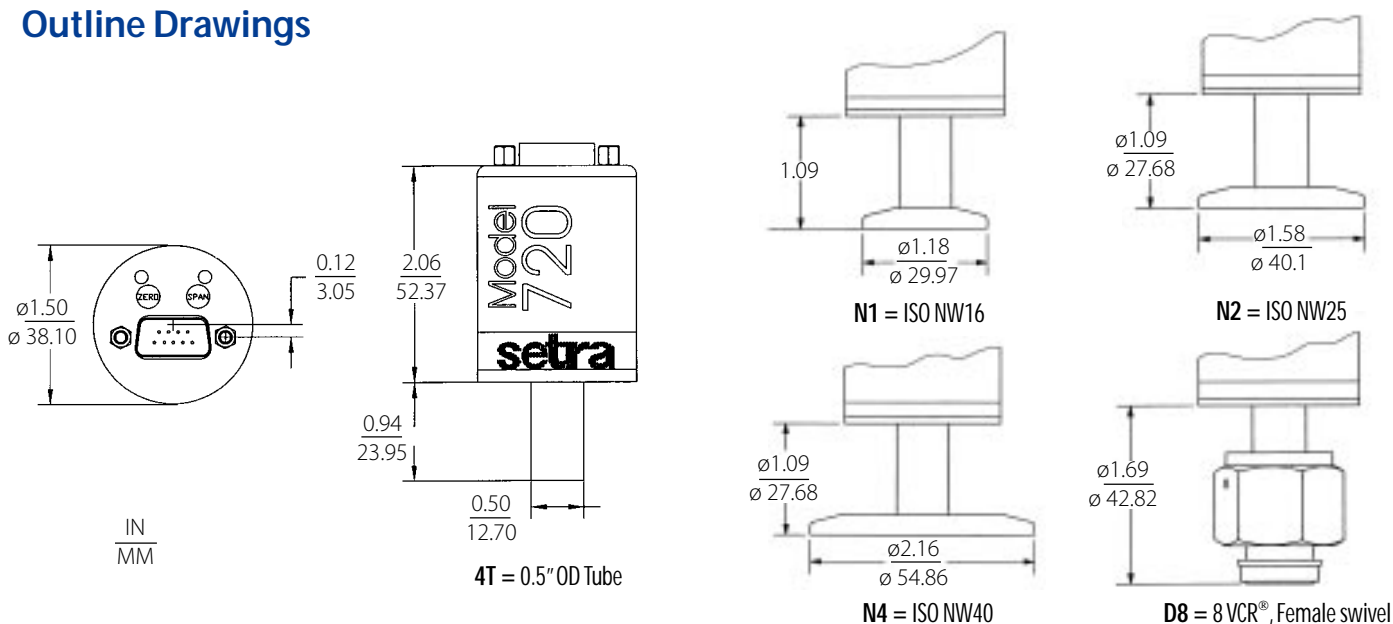

ORDERING INFORMATION

Code all blocks in table.

Example: Part No. 7201 100TAN12CD9A is a Model 720, 0 to 100 Torr Full Scale, Absolute, NW16 Fitting, 10 VDC with a 9 Pin D-Sub and 0.25% of Reading Accuracy.

7	2	0	1	—	—	A	—	—	—	—	—					
Model 7201 = 720				Range 010T = 10 Torr 020T = 20 Torr 100T = 100 Torr 10CT = 1000 Torr 010M = 10 Millibar/hPa 020M = 20 Millibar/hPa 100M = 100 Millibar/hPa 10CM = 1000 Millibar/hPa 001K = 1 kPa 002K = 2 kPa 010K = 10 kPa 100K = 100 kPa			Pressure A = Absolute		Type of Fitting Standard 4T = 0.5" OD Tube N1 = ISO NW16 N2 = ISO NW25 N4 = ISO NW40 D8 = 8 VCR®, Female swivel		Output 2B = 0-5 VDC 2C = 0-10 VDC		Elec. Termination D9 = 9 Pin D-Sub		Accuracy Standard K = ±0.5% of reading <u>Optional</u> A = ±0.25% of reading	
<p>Please contact factory for versions not shown. Note: VCR® and Swagelok® are registered trademarks of Swagelok® Marketing Company, Solon, OH. Conflat® is a registered trademark of Varian Associates, Lexington, MA. Tri-Clover® is a registered trademark of Tri-Clover®, Inc., Kenosha, WI.</p>																

While we provide application assistance on all Setra products, both personally and through our literature, it is the customer's responsibility to determine the suitability of the product in the application.

159 Swanson Road, Boxborough, MA 01719/Tel: 978-263-1400;
Toll Free: 800-257-3872; Fax: 978-264-0292; email: sales@setra.com



SSP720 Rev A 01/12/01