



MODEL 760 VACTRON SERIES OPERATING INSTRUCTIONS

setra



1-800-257-3872 TOLL FREE
1-978-264-0292 FAX
sales@setra.com EMAIL
www.setra.com WEB

**Setra offers a complete line of products
for the semiconductor industry.**

Model 212FT	True Flow-Through Pressure Transducer
Model 216 and 225	Low Cavity Volume Dead-Ended
Models 223 ND 224	Swept Volume Flow Through Pressure Transducers
Model CWS321	Gas Cylinder Weighing Scale
Models 264 and 267	Low Differential Pressure Transducers for Fume Hoods and Clean Rooms

Contents

1.0 Introduction	1
2.0 Mechanical Installation	2
3.0 Electrical Installation	5
4.0 Operation	7
5.0 Calibration and Adjustment of Zero Output	8
5.1 Checking & Zero Adjustment	9
5.2 Span (Full Scale) Adjustment and Calibration	9
6.0 Maintenance & Troubleshooting	9
7.0 Specifications	10
8.0 Reordering Data	11
9.0 Returning Products for Repair	12
10.0 Warranty & Limitation of Liability	13
11.0 FORM 760 ERN - RETURN OF SETRA SYSTEMS PRODUCT-DECLARATION	15

1.0 Introduction

Setra's Vactron Model 760 capacitance manometer is a temperature compensated, absolute pressure transducer designed for accurate and repeatable vacuum measurements. Various full scale ranges are available from 10 Torr up to 1000 Torr. The units of measurement may be specified in Torr (mmHg), mBar (hPa), kPa or psia.

The Model 760 operates from a ± 15 V DC power supply and provides a 0-10 V DC or 0-5 V DC signal output that is linear with pressure and independent of gas composition. Electrical connections can be either the industry standard 15 pin D-sub or 6 position terminal strip connector. The Model 760 is pin for pin compatible with other competitive capacitance manometers. Superior EMI/RFI performance is achieved by the use of a metal case in conjunction with surge and ESD suppression components and RFI filtering on the inputs and outputs. The Model 760 has an integrated sliding cover providing easy access to multi-turn potentiometers for fine zero and span adjustments. Inconel is used for all wetted materials for compatibility with corrosive gases. A wide range of pressure/vacuum fittings are available.

The high accuracy pressure sensing element used in the Model 760 is the Vactron™ sensor, which has been developed from Setra's patented variable capacitance sensor. A centrally located feedthrough assembly supports a circular electrode in close proximity to the back surface of the diaphragm. Together, the electrode and diaphragm form a variable capacitor within a small reference vacuum chamber. As the pressure increases, the diaphragm deflects and the gap between the electrode and diaphragm reduces, causing an increase in the capacitance. This change in capacitance is detected and converted to a highly accurate linear DC electronic signal by Setra's unique custom integrated circuit utilizing a patented charge balance principle.

Excellent zero stability and barometric insensitivity is achieved through the patented sensor design. The Model 760 sensor contains no fragile or complex parts as found in ceramic based capacitance manometers. The all welded construction eliminates stability issues inherent in other designs due to frictional contact between dissimilar materials.

2.0 Mechanical Installation

Remove all packaging material and the protective flange cover and visually check the Model 760. If the Model 760 appears damaged, notify Setra Systems or your supplier immediately. Retain packaging materials for inspection. Do not use if damaged. If the Model 760 is not going to be used immediately, then replace the protective flange cover and store in an area where the temperature range is controlled between -50 to +125°C.

The Model 760 can be mounted in any orientation on the vacuum system. To avoid the buildup of debris or condensable material in the measurement cavity of the Model 760 (which may cause measurement errors), we recommend that you install the Model 760 vertically with the tube facing down. Outline drawings showing the external dimensions are shown in Figures 1 - 4.

To connect the Model 760 to your system use the appropriate hardware for the type of fitting:

- Use a Cajon® Ultra Torr type of compression coupling to connect to the 0.5" OD tube.
- Use an O-ring/centering ring and clamp to connect to the NW16, 25 and 40 flange options.

Note: a stepped O-ring carrier may be used to connect the NW16 flange to an NW10 flange on the system.

- Use a Male 8 VCR™ Style Face Seal Fitting and sealing washer to connect to the female swivel 8 VCR™ Style Face Seal Fitting.
- Use a Male 0.5" Swagelock™ fitting/union to connect to the 0.5" Swagelock™ Nut fitting.
- Use an O-ring and clamp to connect to the 1.5" Triclover™ style sanitary flange.

Note: Tighten threaded fittings in accordance with the manufacturer's specifications.

Figure 1: Outline drawing of 15 pin D connector, 0.5" OD tube.

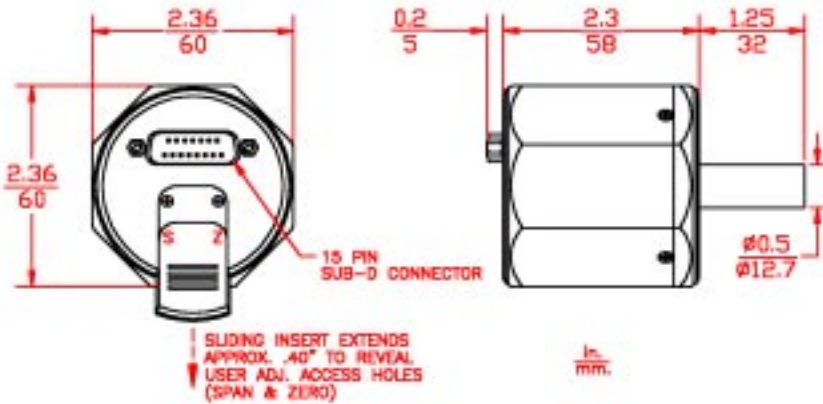

Figure 2: Outline drawing of screw terminal connector (6 position), 0.5" OD tube.

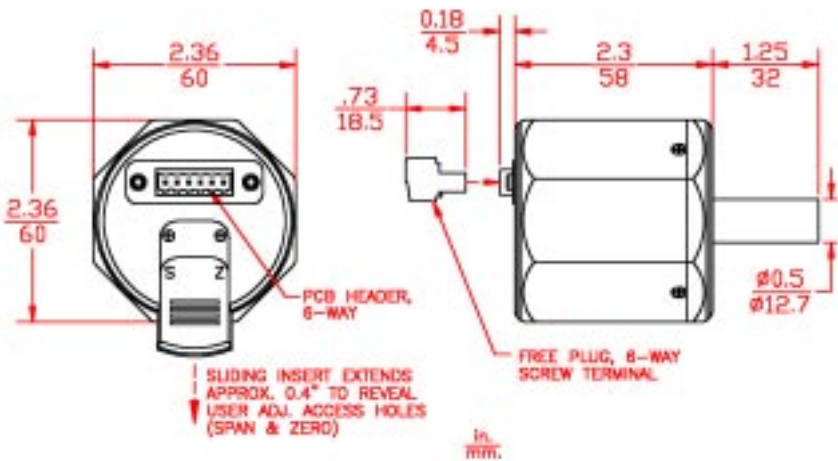

Figure 3: Outline drawing showing optional ISO NW vacuum fitting.

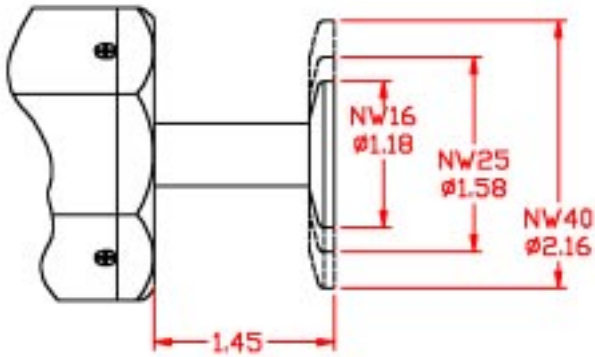
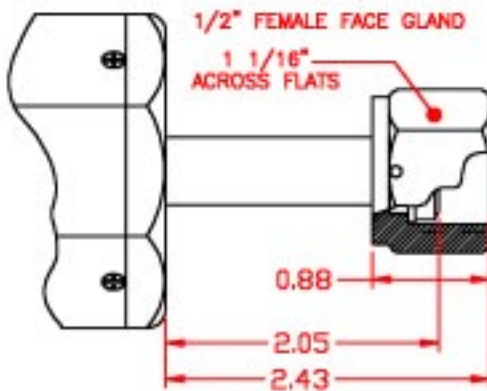

Figure 4: Outline drawing showing optional VCR™ style face seal vacuum fitting.



3.0 Electrical Installation

The pin out for the D-sub, 15 pin connector is shown in Figures 5, page 6. A schematic diagram of the recommended electrical connections to the D-sub, 15 pin connector is shown in Figure 6, page 6.

The pin out for the 6-Position Screw Terminal Connector is shown in Figure 7, page 7. A schematic diagram of the recommended electrical connection to the 6-position Screw Terminal Connection is shown in Figure 8.

The model 760 operates from a ± 15 VDC regulated ($\pm 5\%$) power supply. The model 760 has either a 0-5 VDC output or 0-10 VDC output.

Note 1: The ground of any external power supply and readout system should be the same as the transducer ground (chassis ground) to minimize any possible ground loops which may effect the performance and stability of the transducer.

Note 2: The Model 760 meets CE mark requirements and complies with EMC Directive 89/336/EEC. To ensure compliance when installed, an overall metal braided shielded cable (and metal shielded connectors for the D sub connector option) connected to chassis ground at both ends is required.

Figure 5: Pin out of D-sub Connector (Code D2)

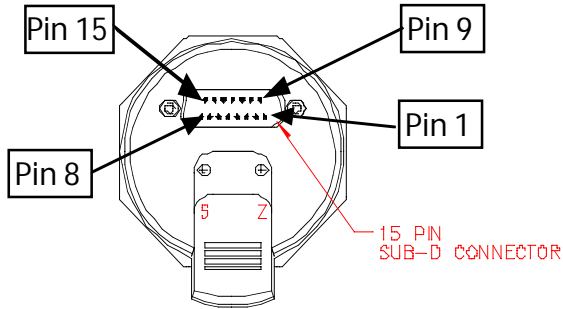

Pin Location	Function
2	Signal Output
5	Power Supply Common
6	Power Supply, -15 VDC
7	Power Supply, +15 VDC
12	Signal Output Common
15	Chassis Ground
1,3,4,8,9,10,11,13,14	Not used

Figure 6: Electrical Connection Schematic - D-sub Connector

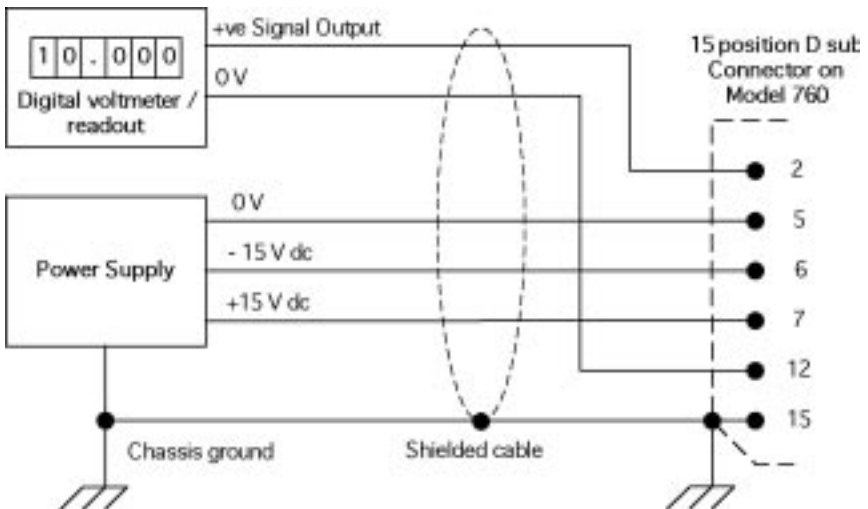
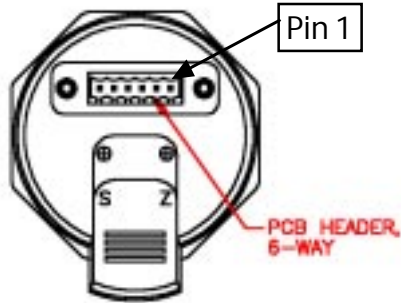
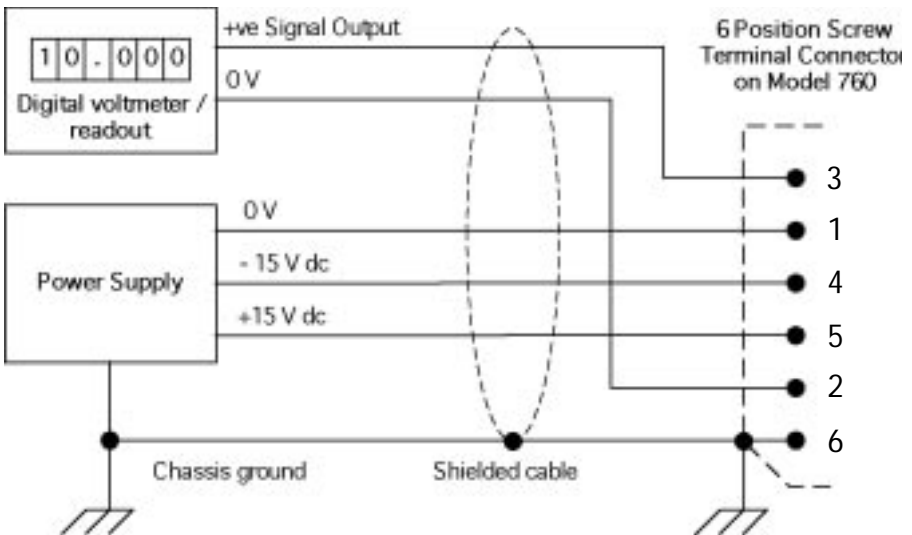

Figure 7 : Pin out of Screw Terminal Connector (Code T2):



Pin Location	Function
1	Power Supply Common
2	Signal Output Common
3	Signal Output
4	Power Supply, -15 VDC
5	Power Supply, + 15 VDC
6	Chassis Ground

Figure 8 : Electrical Connection Schematic - Screw Terminal Connector



4.0 OPERATION

For most accurate pressure measurement, allow the Model 760 to warm up for at least 15 minutes. After installation, periodically check the zero output reading to verify correct output. Adjust the zero potentiometer if incorrect (See Section 5 for zero adjustment instructions).

The signal output of the Model 760 is linear with pressure; e.g., for a 10 VDC FS Model 760, 10 VDC equals 100% FS output, 1 VDC equals 10% FS output.

Table 1 indicates the lowest pressures available for reading and pressure control for each range of the Model 760. The lowest suggested pressure available for reading is limited by the resolution and the accuracy of the Model 760. This is directly related to the electrical noise on the signal output and can be significantly effected by incorrect electrical ground connection, or connection to an electronically noisy power supply or readout instrument. Improved results may be obtained if the transducer is operated in an environment with stable temperature and air flow. The lowest recommended pressure used for control applications, such as a closed loop downstream pressure control system, is based on a signal output of 50 mV.

Table 1: Recommended Lowest Pressures Available for Reading & Pressure Control

Full Scale Range	Recommended Lowest Pressure Reading	Recommended Lowest Pressure for Control
10 Torr	0.005 Torr	0.05 Torr
20 Torr	0.010 Torr	0.10 Torr
50 Torr	0.025 Torr	0.25 Torr
100 Torr	0.050 Torr	0.50 Torr
200 Torr	0.100 Torr	1.00 Torr
500 Torr	0.250 Torr	2.50 Torr
1000 Torr	0.500 Torr	5.00 Torr
10 mbar / hPa	0.005 mbar / hPa	0.05 mbar / hPa
100 mbar / hPa	0.05 mbar / hPa	0.5 mbar / hPa
1000 mbar / hPa	0.5 mbar / hPa	5 mbar / hPa
1 psia	0.0005 psia	0.005 psia
2 psia	0.0010 psia	0.010 psia
5 psia	0.0025 psia	0.025 psia
10 psia	0.0050 psia	0.050 psia
20 psia	0.0100 psia	0.100 psia

5.0 Calibration & Adjustment

5.1 Checking & Zero Adjustment

After installation on a system, the Model 760 may require initial zero adjustment. Figure 9 shows the location of the zero adjustment potentiometer. Slide open the black plastic insert to reveal two access holes. The access hole next to the raised "Z" on the plastic cover identifies the Zero potentiometer.

Use an accurate digital voltmeter to view the signal output of the Model 760. Adjust the signal output of the model 760 to be 0.001 to -0.001 mV. Make this adjustment at a pressure at least 1/2 decade below the Model 760's resolution; e.g., for a 10 Torr FS unit the zero pressure should be less than $5E-4$ Torr. For a 1000 Torr unit, a pressure less than 0.050 Torr is sufficient.

The Zero potentiometer is a multi-turn potentiometer providing very fine adjustment of the zero over a ± 500 mV range.

Figure 9 : Location of Calibration Adjustment Potentiometers

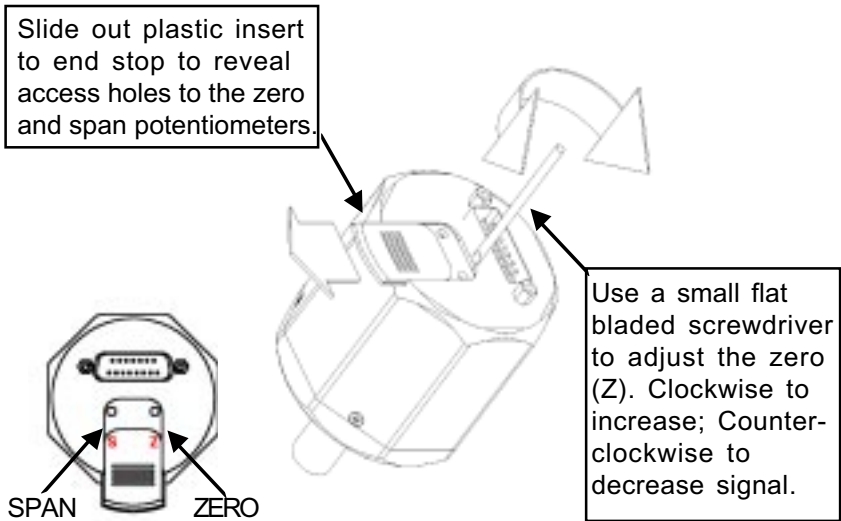

5.2 Span (Full Scale) Adjustment and Calibration

The Zero adjustment is the only adjustment that should be made in the field. Span (Full Scale) adjustments require a calibrated and certified reference standard and should only be attempted by qualified personnel. Return the Model 760 to Setra Systems for periodic calibration, Span (Full Scale) Adjustment and Colibration adjustments and servicing.

6.0 Maintenance & Troubleshooting

There are no general maintenance requirements for the Model 760 other than periodic zero adjustment. If the unit fails to operate when received or if the unit appears damaged, notify Setra Systems or your supplier immediately. Retain packaging materials for inspection. Do not use if damaged. If the Model 760 is not going to be used immediately then replace the protective flange cover and store in suitable conditions described in Section 2.

If no obvious damage has occurred a few simple checks can be made to verify proper installation. Table 2 shows the solution to common problems with the installation. If none of these problems / solutions are applicable, then please contact a Setra Systems applications engineer for further assistance.

Table 2: Common Installation Problems & Solutions

Problem	Cause	Solution
No signal output	Incorrect or no supply voltage	Ensure power supply is used as specified in Section 2.
	Readout display short circuit or incorrect impedance	Ensure impedance of readout unit is > 10 k Ω
Signal output reads over-range	Incorrect wiring	Ensure wiring conforms to diagrams in Section 4.2
	Potential difference between chassis ground of unit , power supply and readout / display	Ensure common chassis ground between unit, power supply and display.
Signal output reads under-range	Incorrect zero adjustment	Adjust zero per section 5.1
	Readout display incorrect impedance	Ensure impedance of readout unit is > 10 k Ω .
	Incorrect wiring polarity to readout display	Ensure wiring conforms to diagrams in Section 4.2
Unstable signal	Chassis ground not connected	Ensure common chassis ground between unit, power supply and display.
	Unstable or unregulated supply	Use a regulated power supply power supply as specified in Section 2.
	Electrical noise on chassis ground	Ensure common chassis ground between unit, power supply and display.

7.0 Specifications

Performance Data:

Accuracy (RSS) ¹ :	< ± 0.25% of Reading Optional < ± 0.15% of Reading
Resolution:	0.01% FS
Thermal effects	
Compensated Range:	0 to +50°C
Zero Shift:	< ± 0.005% FS / °C
Span Shift:	< ± 0.027% FS / °C
Proof Pressure:	45 psia
Operating Temperature:	0 to +50°C
Storage Temperature:	-50 to +125°C

Electrical Data:

Connector:	15 pin D sub or 6 position terminal strip
Excitation:	±15 V DC, regulated ±5%
Output:	0 - 10 V DC or 0 - 5 V DC
Output Maximum Load:	<10 K Ω load
Power Consumption:	< 0.5 Watts (<15 mA)
Time Constant:	< 20 ms
EMC Performance:	Complies with EMC Directive 89/336/EEC

Physical Description:

Case:	Aluminum Alloy
Vacuum Fittings:	0.5" OD Tube; other fittings available; see reorder data page
Wetted Materials ² :	Inconel [®]
Measurement cavity volume ³ :	<6 cm ³
Weight:	260 g

Notes:

1. Root sum of the squares (RSS) of linearity, hysteresis and non-repeatability. Accuracy is expressed as % of reading. However, near Zero, the accuracy is limited by the resolution of the instrument. So, the accuracy is more correctly stated as the greater of ±0.25% reading or ±0.01% FS. (For the optional accuracy, this becomes the greater of ±0.15% reading or ±0.01% FS).
2. Wetted material is for 0.5" tube option only. Other flange options will add stainless steel.
3. Maximum cavity volume including the 0.5" OD tube volume of 0.26 in³ (4.28 cm³).

8.0 Reordering Data

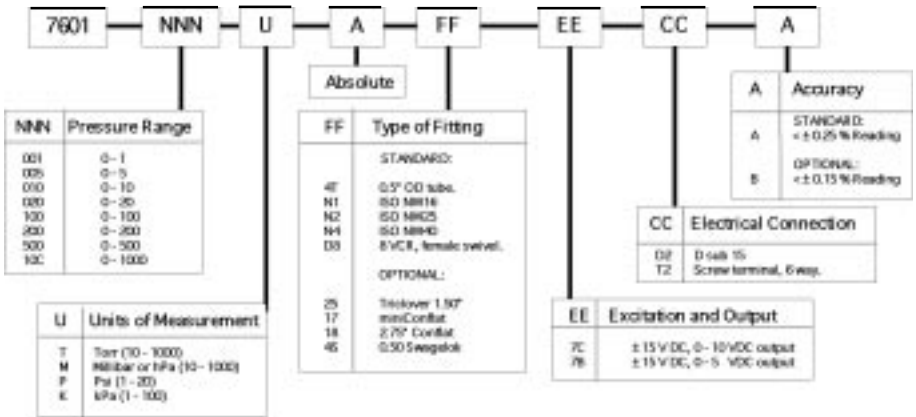

Example: To order a 10 Torr FS unit with ISO NW16 fitting, 0-10 VDC output, D sub 15 electrical connector and an accuracy of ±0.25% Reading, the order code would be: 7601010TAN17CD2A.

9.0 Returning the Model 760 for Repair

Setra Systems cannot accept a Model 760 for repair unless the Form 760ERN is completed. Contact Setra Systems for an ERN Number or the Form 760ERN. Form 760ERN is included in this guide on page 15.

Please contact a Setra application engineer (800-257-3872, 978-263-1400) before returning unit for repair to review information relative to your application. Many times only minor field adjustments may be necessary. When returning a product to Setra, the material should be carefully packaged and shipped prepaid to:

Setra Systems, Inc.
 159 Swanson Road
 Boxborough, MA 01719-1304
 Attn: Repair Department

To assure prompt handling, please supply the following information and include it inside the package of returned material:

1. Name and phone number of person to contact.
2. Shipping and billing instructions.
3. Full description of the malfunction.
4. Identify any hazardous material used with product.

Notes: Please remove any pressure fittings and plumbing that you have installed and enclose any required mating electrical connectors and wiring

diagrams. Allow approximately 3 weeks after receipt at Setra for the repair and return of the unit. Non-warranty repairs will not be made without customer approval and a purchase order to cover repair charges.

Calibration Services

Setra maintains a complete calibration facility that is traceable to the National Institute of Standards & Technology (NIST). If you would like to recalibrate or recertify your Setra pressure transducers or transmitters, please call our Repair Department at 800-257-3872 (978-263-1400) for scheduling.

10.0 Warranty & Limitation of Liability

SETRA warrants its products to be free from defects in materials and workmanship, subject to the following terms and conditions: Without charge, SETRA will repair or replace products found to be defective in materials or workmanship within the warranty period; provided that:

- a) the product has not been subjected to abuse, neglect, accident, incorrect wiring not our own, improper installation or servicing, or use in violation of instructions furnished by SETRA;
- b) the product has not been repaired or altered by anyone except SETRA or its authorized service agencies;
- c) the serial number or date code has not been removed, defaced, or otherwise changed; and
- d) examination discloses, in the judgment of SETRA, the defect in materials or workmanship developed under normal installation, use and service;
- e) SETRA is notified in advance of and the product is returned to SETRA transportation prepaid.

Unless otherwise specified in a manual or warranty card, or agreed to in writing and signed by a SETRA officer, SETRA pressure and acceleration products shall be warranted for one year from date of sale.

The foregoing warranty is in lieu of all warranties, express, implied or statutory, including but not limited to, any implied warranty of merchantability for a particular purpose.

SETRA's liability for breach of warranty is limited to repair or replacement, or if the goods cannot be repaired or replaced, to a refund of the purchase price. SETRA's liability for all other breaches is limited to a refund of the purchase price. In no instance shall SETRA be liable for incidental or consequential damages arising from a breach of warranty, or from the use or installation of its products.

No representative or person is authorized to give any warranty other than as set out above or to assume for SETRA any other liability in connection with the sale of its products.

11.0 RETURN OF SETRA SYSTEMS PRODUCT-DECLARATION

(Form 760ERN)

EXPECTED RETURN NUMBER _____

You must:

- Know about all of the substances which have been used and produced in the product before you complete this Declaration.
- Contact your supplier if you have any questions and for an ERN Number.
- Send this form to your supplier with the return of the product.

SECTION 1: Product

A. Model Number _____

B. Serial Number _____

C. Has the product been used, tested or operated?

Yes - Go to Section 2

No - Go to Section 4

SECTION 2: Substances in Contact with the Product

A. Radioactive* Yes No

B. Biologically Active Yes No

C. Dangerous to Human Health and Safety? Yes No

* Note: Your supplier will not accept delivery of any products that are contaminated with radioactive substances, unless you:

- Decontaminate the products
- Provide proof of decontamination

YOU MUST CONTACT YOUR SUPPLIER FOR ADVICE BEFORE YOU RETURN SUCH PRODUCTS

If you have answered "no" to all of these questions, go to Section 4.

SECTION 3: List of Substances in Contact with the Product

Substance Name	Chemical Symbol	Precautions Required (e.g., use protective gloves, etc.)	Actions Required After Spillage or Human Contact
1.			
2.			
3.			
4.			
5.			
6.			

SECTION 4: Return Information

Reason for return and symptoms of malfunction: _____

If you have a warranty claim:

- Who did you buy the product from?: _____
- Give the supplier's invoice number or your purchase order number: _____

SECTION 5: Declaration

Print your Name: _____ Print Your Job Title: _____

Print Your Company Name: _____

Print Your Address: _____

Telephone Number: _____ Date of Product Return: _____

I have made reasonable inquiry and I have supplied accurate information in this Declaration. I have not withheld any information. I have followed the Return of Setra Systems Product Procedure.

Signed: _____ Date: _____

SS2037 Rev.E 02/06/01

159 Swanson Road, Boxborough, MA 01719-1304
Tel: 800-257-3872/978-263-1400, Fax 978-264-0292
Email: sales@setra.com, Web: www.setra.com

setra