

AccuSense™ Model ASM High Accuracy Pressure Transducer

Pressure Ranges: 15 psi up to 1000 psi



Unparalleled Performance

- 0.05% FS End-Point Accuracy
- Low Thermal Error over Wide Temperature

Small & Robust Package

- 1.3" Diameter—Fits in Tight Locations
- Optional Overpressure Protection up to 10X Proof Pressure

Secure & Simple Field Calibration

- SecureCal™ Eliminates Field Tampering



setra

CE and RoHS Compliant

AccuSense™ Model ASM

Performance You Can Count On

Robust Resonant VC Sensor
Laser welded construction enables high durability

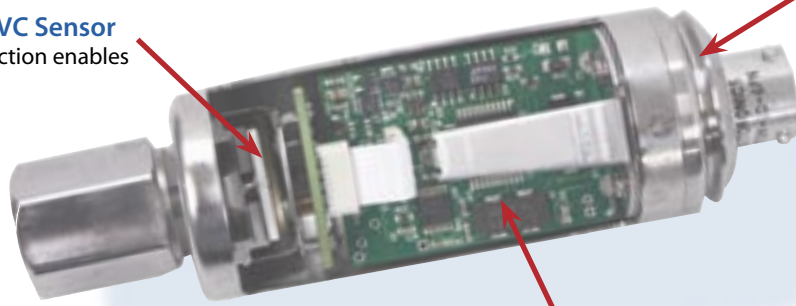

Durable Construction
All stainless steel construction, groove design, and hydrophobic porous plug at top of unit protects the recessed air vent from contaminants in industrial environments

High Performance
Electronics Platform enables outstanding performance over environmental temperature range

Resonant Variable Capacitance (VC) Sensor

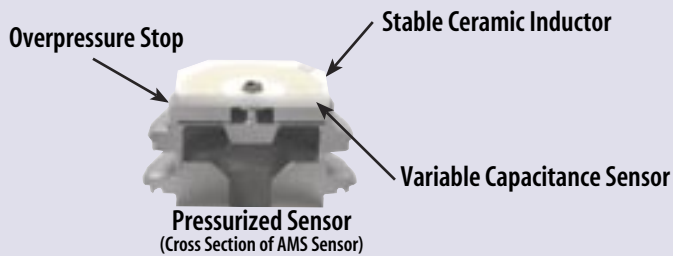

- Resonant VC sensor improved accuracy (no A/D conversion)
- High Stability
- Sensor protection from unintended overpressure exposure

Digital Signal Conditioning

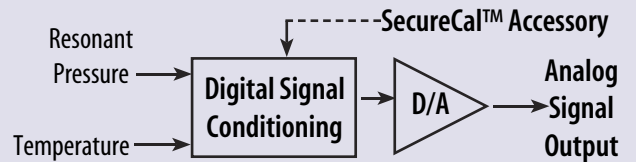

- Linearization
- Thermal Compensation
- Zero/Span Settings

Applications

- Engine Test Stands
- Dynamometers
- Particle Test and Analysis
- Research & Development
- Industrial (High Accuracy)
- Refrigeration Testing

Superior Performance

- Patented sensor enables excellent linearity and stability (Patent # 6,532,834)
- $\pm 0.05\%$ FS (End-Point Accuracy) or 0.1% of Reading accuracy ensures accurate test results
- $\leq \pm 0.25\%$ FS TEB over wide temperature range minimizes thermal errors

High Reliability and Durability

- Patented high overpressure option enables up to 10x proof pressure (Patent #6,718,827)
- High immunity to RFI from wireless devices



SecureCal™ Calibration Accessory

- Eliminates trim pots on transducer, ensuring tamper-proof calibration
- Simple push-button enables zero-tare and snap-span adjustment
- Foolproof factory calibration restore function
- Visual feedback thru LCD & LEDs

Specifications

Performance Data

	Accuracy Code			
	A	B	C	D
Accuracy	<±0.05% FS RSS*	<±0.1% Reading**	<±0.1% FS RSS*	
Non-Linearity	<±0.025% FS End Point Typ.		<±0.05% FS End Point Typ.	
Hysteresis	<0.03% FS Typ.		<0.03% FS Typ.	
Non-Repeatability	<±0.02% FS Typ.		<±0.02% FS Typ.	
Span Setting Tol.	<±0.05% FS		<±0.1% FS	
Zero Offset Tol.	<±0.05% Typ.		<±0.1% FS	
Thermal Total Error Band	<±0.25% FS (-20°C to 60°C)	<±0.50% FS (-20°C to 60°C)	<±1.5% FS Typ. (-20°C to 60°C)	

*RSS: Root Sum Square of endpoint linearity, Hysteresis and Non-repeatability at constant temperature.

** % of Reading accuracy achieved down to 20% of pressure range when zero offset is removed. Below 20% of pressure range uncertainty is ±0.02% FS.

Zero Offset Position Effect	<0.05%/G (Ranges ≥ 100 psi) <0.1%/G (Ranges ≤ 50 psi)
Unit factory calibrated in vertical position (Pressure Port downward)	
Long-term Stability	<0.10%/Year, Typical
Response Time to Pressure Input	<10 ms for Voltage Output
(From 100% to 10% of Pressure Range)	<80 ms for Current Output

Environmental Data

Temperature Calibrated °F (°C)	-4 to 140 (-20 to 60)*
Operating °F (°C)	-40 to +185 (-40 to +85)
Storage °F (°C)	-40 to +185 (-40 to +85)

*Higher or lower temperature limits available (consult factory).

Pressure Media

Gases or liquids compatible with 17-4 PH stainless steel.

Note: Hydrogen not recommended for use with 17-4 PH stainless steel.

Physical Description

Dimensions	See outline drawings on right
Weight	9 oz. (254 g)
Case Materials	Stainless Steel
Moisture / Splash Resistance	NEMA 4X (IP65)
Pressure Fittings	See Ordering Information

Sensor Description

Wetted Materials	17-4 PH SS
Life Cycle Rating	>10 ⁶ Pressure Cycles

Electrical Data

Signal Output Ranges	0-5 VDC, 0-10 VDC (4-wire), 4-20mA (2-Wire)
Excitation Range	9-30V DC (5V DC & 4-20mA output) 15-30V DC (10V DC Output)
Current Consumption	<23 mA
Warm-up, Environmental	Within +/-0.02%FS after 15min Warm-up Time
Miswiring	Reverse Excitation Protection

Configurations

Electrical Terminations	6-Conductor Cable, Pigtail 6-Pin Bayonet Connector
-------------------------	---

Regulatory Data

RoHS Compliant
CE Compliance Standards

Specifications subject to change without notice.

Outline Drawing

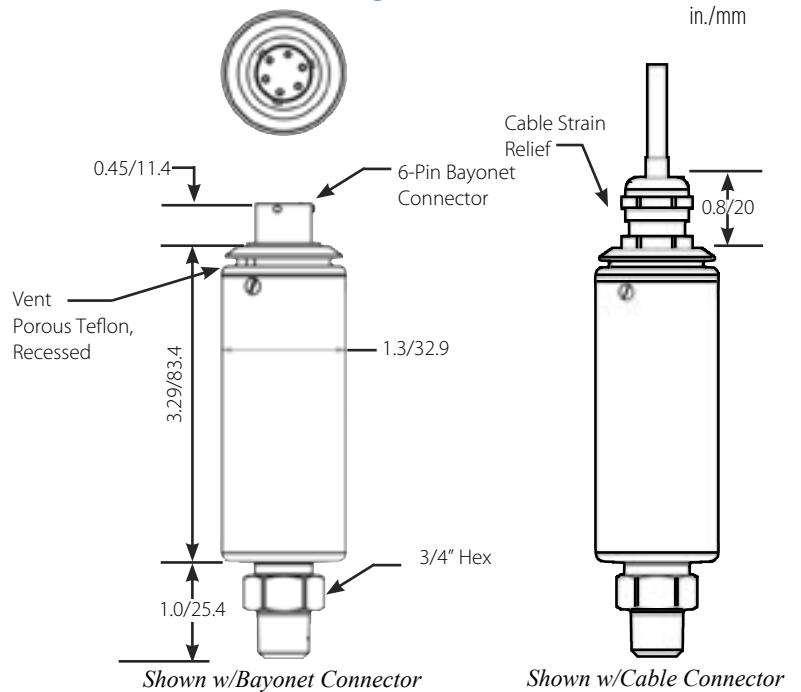

Wiring Codes		Code B3 (Standard)	Code B4 Option	Code B5 Option	Code B6 Option
Electrical Connection	Wire Color	Bayonet Connector Pinout	Bayonet Connector Pinout	Bayonet Connector Pinout	Bayonet Connector Pinout
+ EXC	Red	A	A	A	C
- EXC	Black	D	B	B	D
+ Sig Out	Green	B	C	D	A
- Sig Out	White	C	D	C	B
Reserved for communication with SecureCal™ calibration module					
SecureCal	Blue	E	E	E	E
SecureCal	Brown	F	F	F	F

Pressure Ranges		Standard Code "00"	High Over Pressure Option Code "01"
Full Scale Range (PSI)	Burst Pressure* (PSI)	Proof Pressure** (PSI)	High Proof Pressure (PSI)
15	3000	30 (2x)	150 (10x)
25	3000	50 (2x)	250 (10x)
50	8000	100 (2x)	500 (10x)
100	10,000	200 (2x)	1000 (10x)
150	10,000	300 (2x)	1200 (8x)
200	10,000	400 (2x)	1200 (6x)
300	10,000	600 (2x)	1500 (5x)
500	10,000	800 (1.5x)	2000 (4x)
750	10,000	1200 (1.5x)	2250 (3x)
1000	10,000	1500 (1.5x)	3000 (3x)

* Burst Pressure: the maximum pressure that may be applied to the positive pressure port without rupturing the sensing element.

** Proof Pressure: The maximum recoverable pressure that may be applied without changing performance beyond specification: ±0.5% Zero Shift, Typical

AccuSense™ Model ASM

ORDERING INFORMATION

Code all blocks in table.

Example: Part No. ASM1050PG2M1103A00 for an ASM Transducer 0 to 50 PSI, Gauge, 1/4" NPT Male Pressure Fitting, 4 to 20 mA Output, 3 Feet of Cable, $\pm 0.05\%$ FS RSS <math>< 0.25\%</math> TEB, None, Standard

A	S	M	1						
Model ASM1 = ASM	Pressure Ranges		Type	Pressure Port	Output	Elec. Termination	Accuracy	Option	
	PSI	BAR	G = Gauge C = Compound Gauge A = Absolute V = Vacuum Gauge (Z01 Range Code Only)	1F = 1/8" NPT Female 1M = 1/8" NPT Male 2F = 1/4" NPT Female 2M = 1/4" NPT Male J7 = 7/16"-20 SAE Male	2B = 0 to 5 VDC 2C = 0 to 10 VDC 11 = 4 to 20 mA	03 = 3 ft., 1m Std Cable B3 = Std 6-PIN Male Bayonet Connector, Standard Wiring B4, B5, B6 = 6 Pin Male Bayonet Connector, Optional Wiring (see table)	A = $\pm 0.05\%$ FS RSS <math>< 0.25\%</math> TEB B = $\pm 0.1\%$ Reading <math>< 0.25\%</math> TEB C = $\pm 0.1\%$ FS RSS <math>< 0.5\%</math> TEB D = $\pm 0.1\%$ FS RSS <math>< 1.5\%</math> TEB	00 = None, Standard 01 = High Overpressure (See Table)	
	Z01P = 0 to -14.7 PSI 015P = 0 to 15 PSI 025P = 0 to 25 PSI 050P = 0 to 50 PSI 100P = 0 to 100 PSI 150P = 0 to 150 PSI 200P = 0 to 250 PSI 300P = 0 to 300 PSI 500P = 0 to 500 PSI 750P = 0 to 750 PSI 10CP = 0 to 1000 PSI	Z01B = -1 BAR 002B = 2 BAR 005B = 5 BAR 010B = 10 BAR 020B = 20 BAR 040B = 40 BAR 050B = 50 BAR 070B = 70 BAR							

6-Pin Bayonet Connector Assembly w/Strain Relief
Order Separately: Part No. 600751



SecureCal™ Calibration Key



Specifications

Display

Type	LCD STN Gray Reflective
Number of Characters	8 CH x 2 Lines
Character Size	1.845 mm W x 2.595 mm H

Environmental

Temperature	
Operating °F (°C)	+32 to +122 (0 to +50)
Storage °F (°C)	-4 to +158 (-20 to +70)

Electrical Data

Nominal Excitation	24 VDC
Excitation Range	15 - 30 VDC
Interface with Sensor	RS232 Communications

Outline Drawing

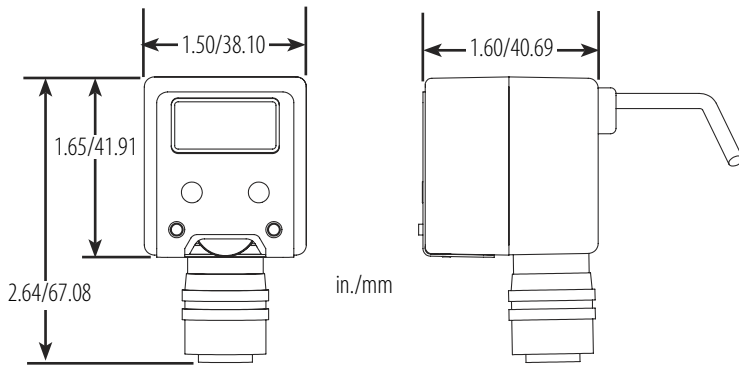

ORDERING INFORMATION

Code all blocks in table.

Example: Part No: SSC1VB3B03R00 for SecureCal Accessory, Voltage Input, 6-Pin Bayonet, Female, Bottom, 3ft. cable, None, Standard

S	S	C	1						
Model SSC1 = SSC	Input V = Voltage (0 - 5 VDC and 0 - 10 VDC) C = Current (4 - 20 mA)	Connection to AccuSense™ Transducer TBR = Removeable Terminal Block, Rear B3B = Std 6-Pin Bayonet, Female, B3 Wiring Code, Bottom B4B, B5B, B6B = 6-Pin Bayonet, Female, Optional Wiring, B4, B5, B6 Wiring Code, Bottom (see table)		Connection to Power Supply 03R = 3 ft. (1m) Cable (for Code TBR), Rear		Options 00 = None, Standard			

While we provide application assistance on all Setra products both personally and through our literature, it is the customer's responsibility to determine the suitability of the product in the application.