

Process Camera for Live, Remote Viewing into Vessels

Data Sheet 05-0010 04/01



For live, remote viewing inside a vessel or a tank, the new easy-mount camera from L.J. Star Incorporated combines high performance video imaging capability with unparalleled durability. This compact, lightweight camera can be mounted onto virtually any existing sight port or sanitary connection. Or, L.J. Star can provide an integrated video/sight glass assembly to meet your specific application requirements.

It can be used to monitor cleaning, spray patterns, mixing, foaming, reactions and level in non-hazardous areas. Using it, an operator can exercise remote visual control over a process, safely and efficiently, whether the application entails one vessel or a number of vessels. The addition of a standard video recorder makes it possible to create visual, real-time records of these processes.

The camera is available in black & white or color versions, with resolutions up to 450 TV lines. Lenses are available in 6 sizes with focal lengths ranging from 2.9mm to 16.0mm to optimize the desired field of view. The package measures 5-3/4 inches high by 3-1/2 inches in diameter and the unit weight is only 4 lbs.

The housing is made of corrosion resistant anodized aluminum and is dust and waterjet tight. An adjustable stainless steel mounting bracket is provided to allow for accurate adjustment of the camera view. A 4" clamp connection is available for sanitary applications.

To maintain a clear view, we recommend combining the viewing sight port with the appropriate L.J. Star spray device to wash or purge debris from the product side of the glass window. For very difficult applications, a wiper assembly can also be provided to manually clean condensate, product or dust on the inside glass surface.

For additional information and applications assistance contact:

L.J. Star Incorporated

P.O. Box 1116, Twinsburg, OH 44087

Phone: (330) 405-3040 • Fax: (330) 405-3070

Web Page: www.ljstar.com • e-mail: view@ljstar.com

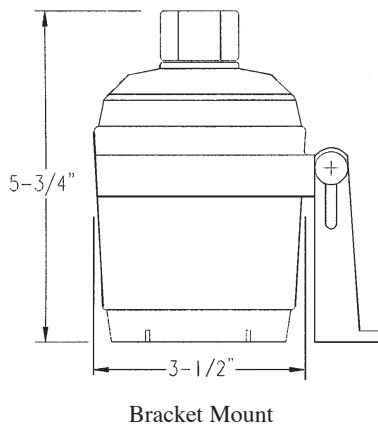

Bracket Mount

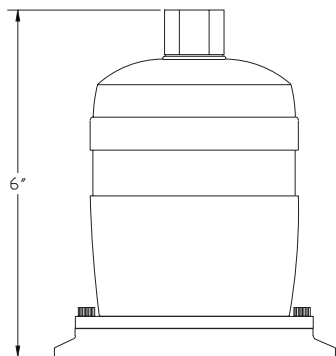

Sanitary Clamp Connection

L.J. STAR
INCORPORATED

CAMERA SPECIFICATIONS

	<u>B&W</u>	<u>DSP Color*</u>	<u>DSP Color Hi Res*</u>
Pick Up Device	1/3" CCD b/w	1/3" CCD color	1/3" CCD color
Resolution	410 TV lines	350 TV lines	450 TV lines
S/N Ratio	50dB	46dB	46dB
Video Output	1Vp-p/75 Ohms	1Vp-p/75 Ohms	1Vp-p/75 Ohms
Light Sensitivity	0.10 lux @ F 2.0	0.09 lux @ F 2.0	0.09 lux @ F 2.0
Electronic Iris	1/60-1/100,000 sec	1/60-1/100,000 sec	1/60-1/100,000 sec
Input voltage	8.5-18 VDC unregulated	10-15 VDC regulated	10-15 VDC regulated
Current Consumption	125 mA @ 12VDC (1.5W)	250 mA @ 12VDC (3.0W)	250 mA @ 12VDC (3.0W)
Surge Suppression	1.5kW transient	1.5kW transient	1.5kW transient
Operating Temperature	-4°F to 140°F	-4°F to 122°F	-4°F to 122°F
Optional Power Supply	9 VDC, 500mA unregulated	15 VDC, 400mA regulated	15 VDC, 400mA regulated

* DSP stands for DIGITAL SIGNAL PROCESSING. The color cameras include a digital signal processor that enhances image quality and light sensitivity.

ENCLOSURE

	<u>Standard Housing</u>	<u>Sanitary Design</u>
Dimensions (D x H)	3-1/2" x 5-3/4"	3-1/2" x 6"
Weight	4 lb.	5 lb.
Material	Marine grade aluminum	Marine grade aluminum
Bracket	Stainless steel	N/A
Window	Polycarbonate	Metaglas® (borosilicate glass)
Enclosure Coating	Clear anodized	Clear anodized
Connection	3" view or greater sight port	4" or greater sanitary clamp connection

TESTS & APPROVALS

Completed and Passed

- High temperature (IEC 68-2-2 Test B)
- Low temperature (IEC 68-2-1 Test A)
- Temperature cycling (IEC 68-2-14 Test N)
- Shock (IEC 68-2-27 Test Ea)
- Vibration (IEC 68-2-6 Test Fc)
- Humidity (IEC 68-2-30 Test Db)
- Salt fog (IEC 68-2-11 Test Ka)

IP 67 - Meets or Exceeds

- Nema Hose Down Test (250-1985)
- Nema Rain Test (250-1985)
- Dust Test (SAE J1211)

LENS CHART

Lens Size (mm)	Viewing Angle		Field of View									
	H	V	5 feet away		10 feet away		15 feet away		25 feet away		50 feet away	
			H	V	H	V	H	V	H	V	H	V
2.9	90°	67°	10.0	6.6	20.0	13.2	30.0	19.9	50.0	33.1	100.0	66.2
3.6	74°	55°	7.5	5.2	15.1	10.4	22.6	15.6	37.7	26.1	75.4	52.1
6.0	42°	32°	3.8	2.9	7.7	5.7	11.5	8.6	19.2	14.4	38.4	28.7
8.0	32°	24°	2.9	2.1	5.7	4.3	8.6	6.4	14.4	10.7	28.7	21.3
12.0	22°	17°	1.9	1.5	3.9	3.0	5.8	4.5	9.7	7.5	19.4	14.9
16.0	15°	11°	1.3	1.0	2.6	1.9	3.9	2.9	6.6	4.8	13.2	9.6