

USER'S GUIDE

Installation & Operation
Instructions

Doppler Flow Meter
Model DFM 5.0
Manual Series A.1

Note: This page has been left blank intentionally.

INDEX

Connections	4
Keypad System	5
Calibration Menu	6
Message	7
Status	7
Password	8
Units/Mode	9
Calibration	10
Relay Parameters	11
Special Functions	13
Sensor Mounting	15
Enclosure Installation	19
Synchronization	20
Troubleshooting	21
Common Questions And Answers	24
Applications Hotline	26
Product Return Procedure	27
Warranty	29
Flow Meter Data Sheet	28
Warranty	29
Appendix A – Options	30
Data Logger	35
Specifications	37
Appendix B - Conversion Table	38
Pipe Charts	39

IMPORTANT NOTE: This instrument is manufactured and calibrated to meet product specifications. Please read this manual carefully before installation and operation. Any unauthorized repairs or modifications may result in a suspension of the warranty.

Available in Adobe Acrobat pdf format

CONNECTIONS:

POWER INPUT: The standard model requires AC power input between 100 to 240 VAC 50/60Hz (2 amp fuse is recommended). No adjustments are necessary for voltages within this range.

Optional DC input model requires 9-32 VDC/0.54 Amps. Connect to + and - terminals. Connect L (Live) N (Neutral) and AC Ground.

IMPORTANT NOTE: To comply with CSA/UL electrical safety standards, AC power input and relay connection wires must have conduit entry to the instrument enclosure.

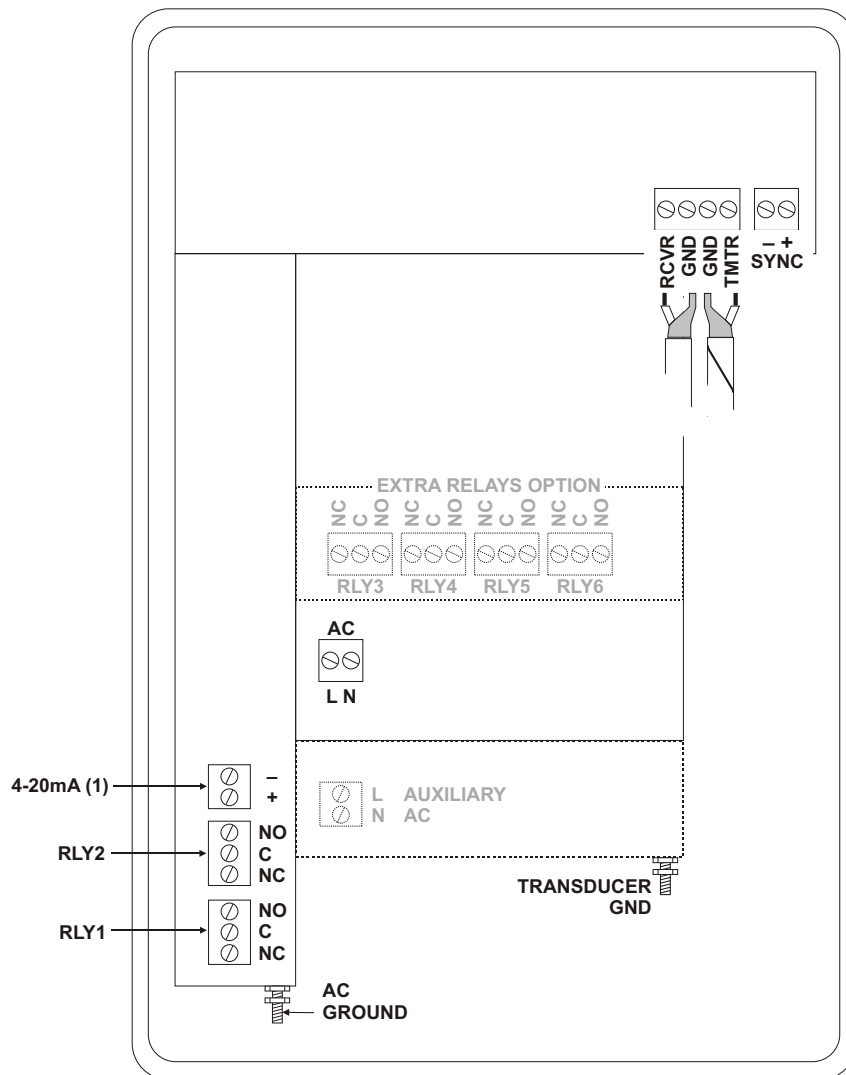

KEYPAD SYSTEM

The following diagram shows the DFM 5.0 menu system. Arrows show the four directions to leave a menu box. Pressing a corresponding keypad arrow will move to the next item in the direction shown. Move the cursor (underline) under numerals and increase or decrease numerals with the **↑** and **↓** keys.

To store calibration values permanently (even through power interruptions), press the **✓**.

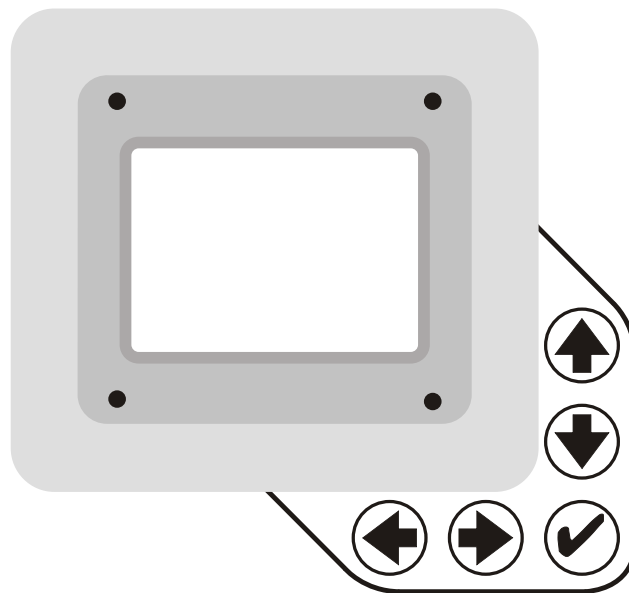

CALIBRATION MENU

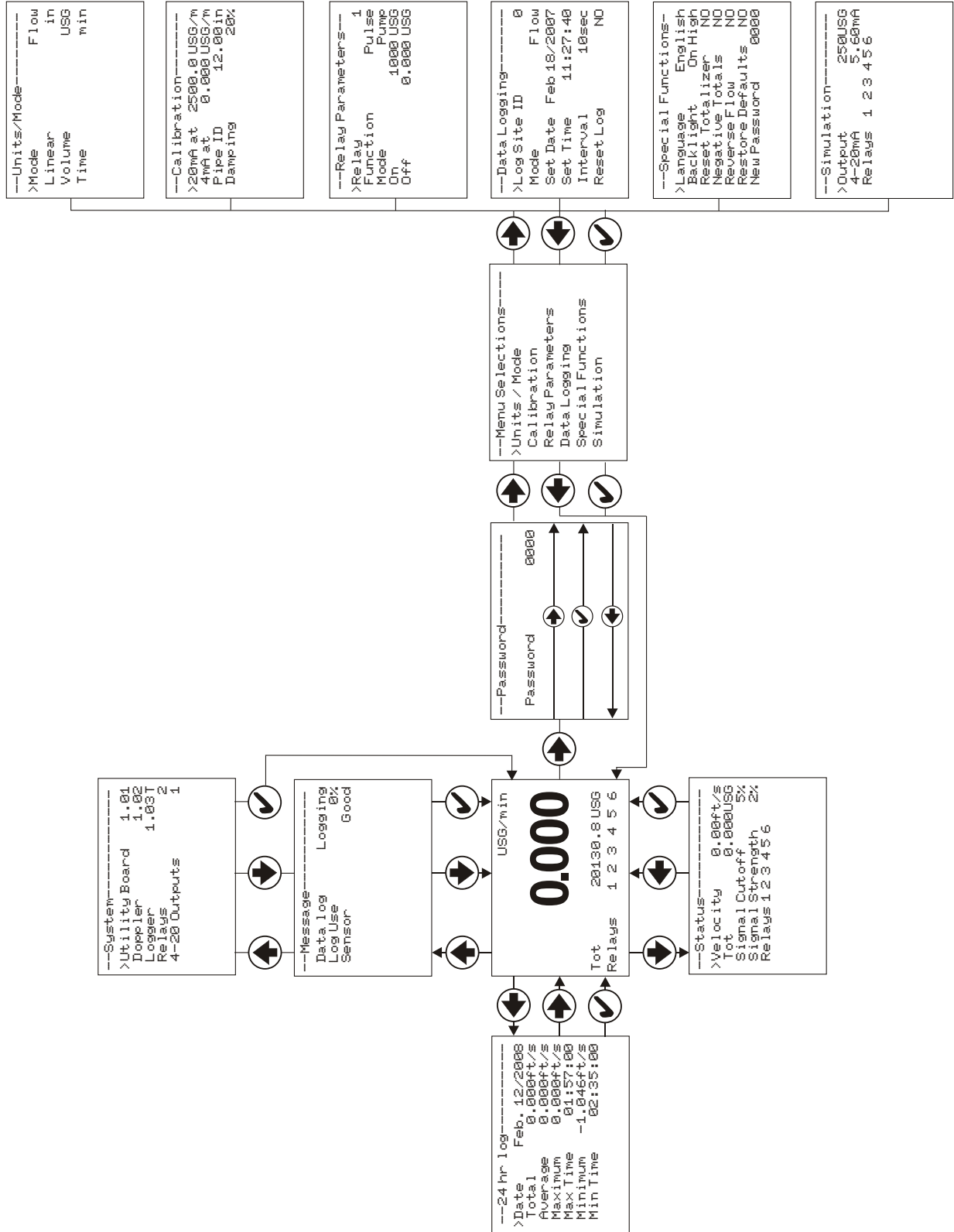

```
USG/min
0.000
Tot      20130.8 USG
Relays   1 2 3 4 5 6
```

RUN

The main display shows the units selected from the Units/Mode menu, Flow or Velocity rate being measured, TOTALIZER and RELAY states. The DFM 5.0 will start-up with this display and will return to this screen after a timeout if keys are not pressed in other menus.

```
--Message-----
Data log      Logging
Log Use       0%
Sensor        Good
```

MESSAGE

Press **↑** from the RUN display to view status of the data logger and error/warning messages provided by the instrument. The word Message will appear on the RUN display if error messages are being generated by the instrument. Refer to the manual section Error/Warning Messages for a description. Press **✓** to return to the main display.

```
--Status-----
>Velocity     0.00ft/s
Tot           0.000USG
Signal Cutoff 5%
Signal Strength 2%
Relays 1 2 3 4 5 6
```

STATUS

Press **↓** from the RUN display to view instrument status. Velocity will be displayed in ft/sec or m/sec.

Tot Displays the current totalizer reading.

Signal Cutoff Adjust the setting in percent to suppress flow readings at zero flow when fluid swirling or pipe vibration may cause the instrument to continue reading. Example: Signal Cutoff at 5% will force the display and outputs to zero when signal strength drops below 5%.

Signal Strength Displays percentage of signal being received by the ultrasonic sensor.

Relays Energized relays will display as a white character on a black background.

20mA = Displays the flow rate set as 20mA in the Calibration menu. Press **✓** to return to the main display.

```
--24 hr log-----
>Date        Feb. 12/2008
Total        0.000ft/s
Average      0.000ft/s
Maximum      0.000ft/s
Max Time     01:57:00
Minimum      -1.046ft/s
Min Time     02:35:00
```

24 HR LOG

Press **←** from the RUN display to view a formatted flow report from instruments with a built-in data logger. Press **↓** to scroll down one day or repeatedly to scroll to a specific date. Up to 365 days can be stored. Newest date will overwrite the oldest. Press **✓** to return to the main display.

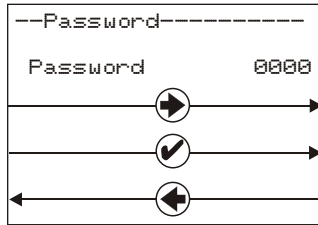

PASSWORD

The password (a number from 0000 to 9999) prevents unauthorized access to the Calibration menu.

From the Run display press the **➡** key to get to **PASSWORD**. Factory default password is 0000 and if it has not been changed press the **✓** to proceed to the Menu Selections screen.

If a password is required, press **➡** to place the cursor under the first digit and **↓** or **↑** to set the number, then **➡** to the second digit, etc. Press **➡** or **✓** to proceed to the Menu Selections screen.

A new password can be stored by going to **Special Functions/New Password**.

```
--Units/Mode-----
>Mode          Flow
Linear         in
Volume        USG
Time          min
```

UNITS/MODE

From >Mode press the **➡** and then the **⬆** or **⬇** to select Flow or Velocity. Flow mode displays the flow rate in engineering units (e.g. gpm, litres/sec, etc.) Press the **✓** to store your selection then the **⬇** to the next menu item and **➡** to enter.

```
--Units/Mode-----
Mode          Flow
>Linear       in
              ft
              %
              M
              MM
```

From >Linear press the **➡** key and then the **⬆** or **⬇** to select your units of measurement. Press the **✓** to store your selection.

Press the **⬇** key to move the **>** symbol to each subsequent menu item and the **✓** to save your selections.

Note: the volume selection "brl" denotes U.S. oil barrel.

```
--Units/Mode-----
>Volume       USG
              ft3
              bbl
              L
              M3
              IMG
              IG
              USMG
```

Press **⬅** or **✓** to return to the Menu Selections screen.

```
--Units/Mode-----
Mode          Flow
Linear         in
Volume        USG
>Time         sec
              day
              hr
              min
```

```
--Calibration-----  
>20mA at 2500.0 USG/m  
4mA at 0.000 USG/m  
Pipe ID 12.00in  
Damping 20%
```

CALIBRATION

Press the **↓** to >Calibration and **→** to enter. Use **↓** or **↑** to position **>** before each menu item and **→** to enter. When settings are completed press **✓** to store and return to the Calibration menu

20mA at Press **→** then **↓** or **↑** to change the numbers and decimal point. Use this menu to set the corresponding flow rate that will be represented by 20mA analog output. If maximum flow is unknown, enter an estimated flow rate and observe actual flow to determine the correct maximum value. Any velocity or flow rate up to +40 ft/sec (12.2 m/sec) may be selected.

4mA at Press **↓** or **↑** to set the flow rate corresponding to 4mA analog output. This setting may be left at zero flow (or velocity or can be raised to any value less than the 20mA setting, or lowered to any velocity or corresponding flow rate down to -40 ft/sec (-12.2 m/sec).

Pipe ID Place the cursor under the digits and then **↓** or **↑** to change the numbers and decimal point. **Pipe ID** should be entered as the exact inside diameter of the pipe where the sensor is mounted. Refer to the Pipe Charts Appendix in this manual for inside diameter of common pipe types and sizes.

Damping - Increase damping to stabilize readings under turbulent flow conditions. Decrease for fast response to small changes in flow. **Damping** is shown in percentage (maximum is 99%). Factory default is 20%.

Press **✓** from the **Units/Mode** display to return to Menu Selections.

```
--Relay Parameters--
>Relay                1
Function              Pulse
Mode                  Pump
On                    1000 USG
Off                   0.000 USG
```

RELAY PARAMETERS

Relay Press **→** and **↓** or **↑** to select a corresponding relay number (2 relays are standard, 4 additional are optional).

Function Press **↓** or **↑** to select **Off**, **Pulse** or **Flow**.

Mode Select **Pump**, **Low Alarm** or **Hi Alarm**.

Pump mode provides separate **On/Off** settings where the relay will energize at one flow rate and de-energize at another.

Low Alarm mode relay will energize at a programmable flow rate and remain energized with flow below the set point. When flow rises above the set point, the relay will de-energize.

Hi Alarm mode relay will energize at a programmable flow rate and remain energized with flow above the set point. When flow falls below the set point, the relay will de-energize.

On Position the cursor under the numerals and press **↓** or **↑** to set digits to the required relay **On** set point

Off set digits to the required **Off** set point.

Return to **Relay** and change settings for each relay number.

Press **✓** to return to **Menu Selections**.

```
--Data Logging-----
>Log Site ID      0
Mode              Flow
Set Date         Feb 18/2007
Set Time         11:27:40
Interval         10sec
Reset Log        NO
```

DATA LOGGING (OPTIONAL)

This menu will appear only if the instrument is equipped with an optional data logger.

Log Site ID A unique ID number which will appear in individual data log files to help identify the instrument the log file was downloaded from.

Mode Select **Flow** or **Velocity**. Logging mode is independent of the instrument calibration.

Flow mode will log readings in volumetric units (e.g. gpm or L/s)

Velocity mode will log readings in ft/sec or m/sec.

Set Date required for data logging

Set Time required for data logging

Interval Select the flow logging interval from 10, 30 seconds, or 1, 2, 5, 10, 30, 60 minutes.

Reset Log Select **Yes** to reset the log and erase all previous stored data. Leave the setting at **No** to retain existing data in the log.

Press **✓** to return to **Menu Selections**.

```
--Special Functions--
>Language      English
Backlight      On High
Reset Totalizer NO
Negative Totals NO
Reverse Flow    NO
Restore Defaults NO
New Password    0000
```

SPECIAL FUNCTIONS

Language Select English, French or Spanish

Backlight Select On High, Medium or Low for continuous backlight.

Select Key Hi/Lo for high backlight for 1 minute after a keypress and then Lo backlight until a key is pressed again.

```
--Special Functions--
Language      English
>Backlight    On High
              On Med
              On Low
Key Hi/Lo
Key High
Key Med
Key Lo
Off
```

Select Key High, Med or Low for backlight for 1 minute after a keypress and then backlight off until a key is pressed again.

Reset Totalizer Press **▶** and select **Yes** to erase and restart the totalizer at zero.

Negative Totals Select **Yes** to have reverse flow readings deducted from the totalizer. Select **No** to totalize forward flow only and ignore reverse flow. [review]

Reverse Flow Select **Yes** to change the display from positive or negative values (e.g. sensor mounted in a direction that shows normal flow as negative values. Use **Reverse Flow** to change readings to positive values.)

Restore Defaults Select **Yes** and press **✓** to erase all user settings and return the instrument to factory default settings. [review]

New Password Select any number from 0000 to 9999 and press **✓**. Default setting of 0000 will allow direct access to the calibration menus. Setting of any password greater than 0000 will require the password to be entered to access the calibration menus.

Press **✓** to return to **Menu Selections**.

```
--Simulation-----  
>Output      250USG  
4-20mA      5.60mA  
Relays  1 2 3 4 5 6
```

SIMULATION

Exercises the 4-20mA output, digital display and control relays (does not affect the totalizer or optional data logger).

Output Press **➡** and then **⬇** or **⬆** to change the simulated output. Press **✓** to begin simulation. The 4-20mA output and relay states will be displayed on the screen below.

Press the **✓** to terminate simulation and return to the **Menu Selections** screen.

SENSOR MOUNTING LOCATION

The position of the sensor is one of the most important considerations for accurate Doppler flow measurement. The same location guidelines apply to Doppler as most other types of flow meters.

Before permanently mounting a Doppler sensor onsite testing is recommended to determine optimum mounting position. Use the sensor coupling compound (supplied with each Greyline flow meter, or petroleum gel, acoustic compound or electrocardiograph gel). Take several readings around the axis of the pipe and then at several points upstream and downstream from the selected position, checking for consistent readings. Avoid high or low reading areas. Mount the sensor where consistent (average) readings were obtained or continue testing on another pipe section.

VERTICAL OR HORIZONTAL PIPE - Vertical pipe runs generally provide evenly distributed flow. On Horizontal pipes and liquids with high concentrations of gas or solids, the sensor should be mounted on the side (3 or 9 o'clock position) to avoid concentrations of gas at the top of the pipe, or solids at the bottom. For liquids with minimal gas bubbles (e.g. potable water) the sensor should be mounted on the top of a horizontal pipe (12 o'clock position) to obtain the best signal strength.

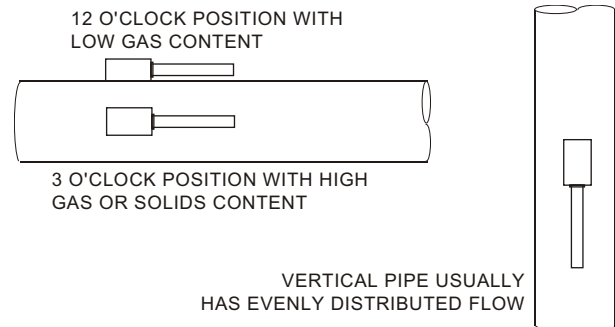

VELOCITY INCREASING DEVICES: Generally the sensor must be mounted away from flow disturbances such as valves, pumps, orifice plates, venturis or pipe inlets and discharges which tend to increase flow velocity. Velocity increasing devices often cause cavitation, or rapid release of gas bubbles, and readings both up and downstream may show much higher velocity. As a guideline, mount the sensor at least 20 diameters upstream or 30 diameters downstream from velocity increasing devices.

Required distance from a velocity increasing device will vary in applications depending on the flow velocity and the characteristics of the liquid itself.

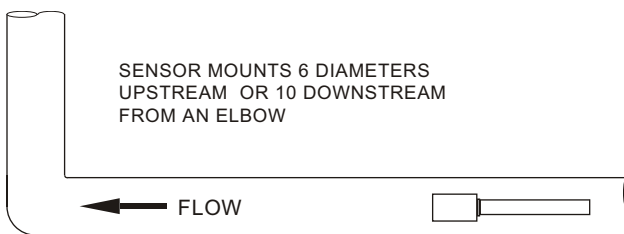

TURBULENCE INCREASING DEVICES: Elbows, flanged connections and tees tend to introduce desirable conditions of an evenly distributed flow profile with some air or gases entrained in the flow. Sensor mounting 6 pipe diameters upstream and 10 diameters downstream from these disturbances is generally optimum.

The sensor is designed to mount longitudinally on a straight section of pipe. Do not attempt to mount it on bends, elbows or fittings.

SENSOR MOUNTING

Prepare an area 2" wide by 4" long (50mm x 100mm) for sensor bonding by removing loose paint, scale and rust. The objective of site preparation is to eliminate any discontinuity between the sensor and the pipe wall, which would prevent acoustical coupling.

A PC4 Sensor Mounting Kit is supplied with each Greyline flow meter. It includes recommended coupling compound in a plastic applicator and a stainless steel mounting bracket with adjustable pipe straps.

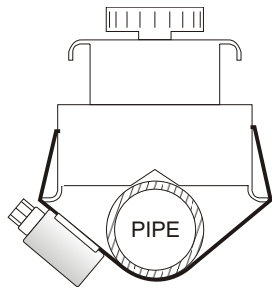

END VIEW

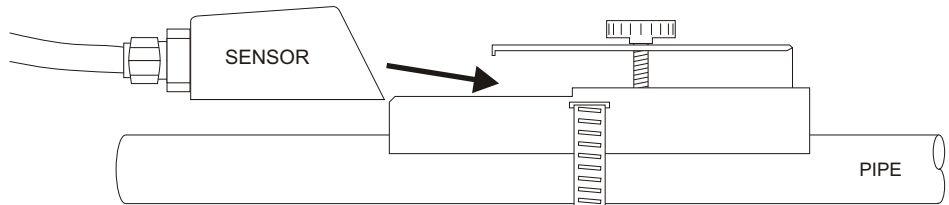

Mount the PC4 pipe clamp as illustrated on pipes 0.6" / 15 mm OD or larger. Stainless steel bands are included for mounting on pipes up to 32" / 81 cm OD.

Additional stainless steel bands (by customer) may be combined to mount on pipes up to 180" / 4.5 m OD.

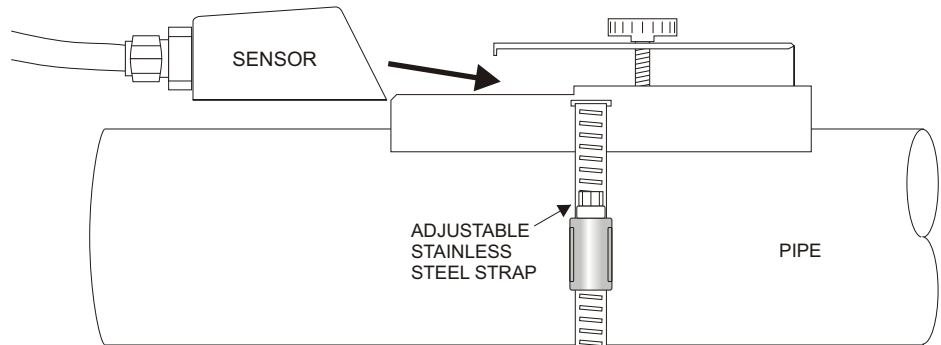
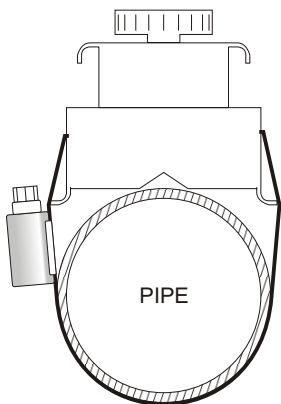

SENSOR COUPLING

For permanent or temporary bonding, the following are recommended:

- a) Dow Corning silicon compound #4 (supplied)
Additional supply: order Greyline Option CC
- b) High Temperature compound (supplied with Sensor Option SE3H)
Additional supply: order Greyline Option AP-1W
- c) Water-based sonic compound: Order Greyline Option CC30
- d) Electrocardiograph gel
- e) Petroleum gel (Vaseline)

The above are arranged in their order of preferred application.

d & e are only good for temporary bonding at room temperature.

DO NOT USE: Silicon RTV caulking compound (silicon rubber).

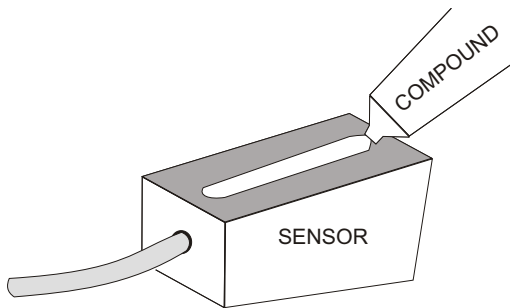

Use the PC4 pipe clamp (supplied) as illustrated above or use a loop of electrical tape for temporary mounting. Apply silicon coupling compound #4 to the coloured face of the sensor. A bead, similar to toothpaste on a toothbrush, is ideal. Do not overtighten (crush the sensor).

The sensor must be fixed securely to the pipe with coupling material between the sensor face and the pipe. Sensor installation with excessive coupling compound can result in gaps or voids in the coupling and cause errors or loss of signal. Insufficient coupling compound will create similar conditions.

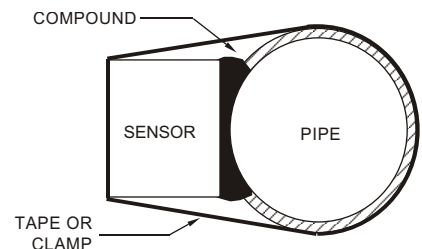

Over time temporary coupling compounds (e.g. Petroleum Gel) may gradually sag away from the sensor resulting in reduced signal strength and finally complete loss of signal. Warm temperatures, moisture and vibration will accelerate this process. Dow Corning Silicone Compound #4 as supplied with the DFM 5.0 (and available from Greyline Instruments) is recommended for semi-permanent installations.

SENSOR MOUNTING/COUPLING RECOMMENDATIONS

BAD

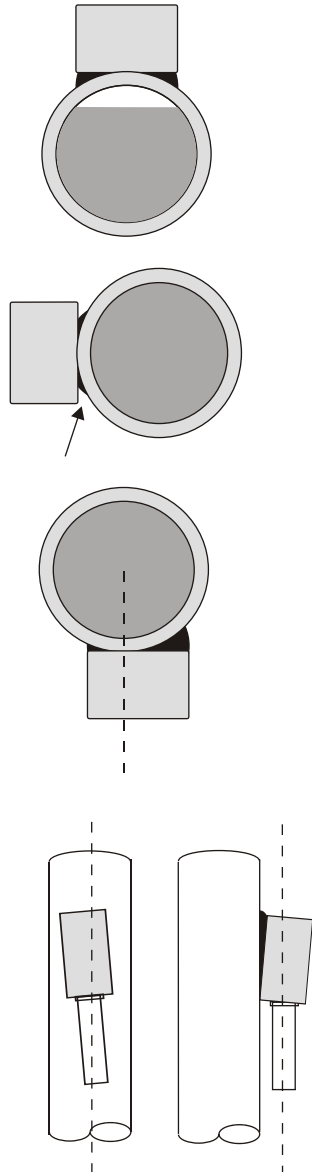

GOOD

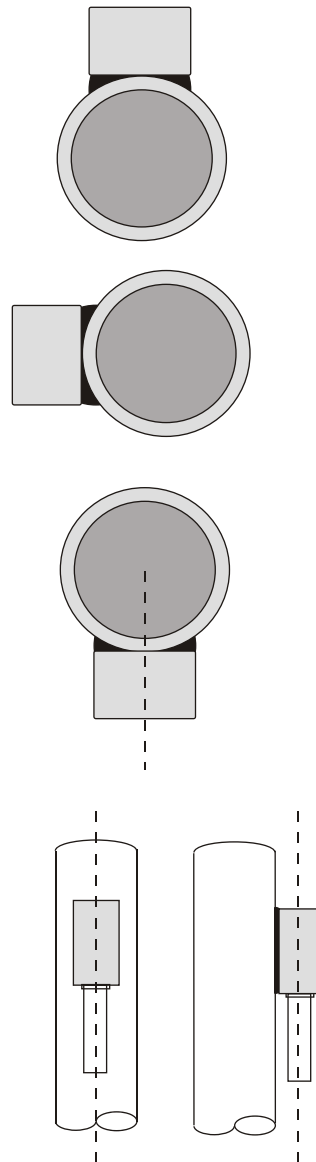

ENCLOSURE INSTALLATION

Locate the enclosure within 20 ft (6 m) of the sensor (500 ft -150 m optional). The enclosure can be wall mounted with the four mounting screws (included) or panel mounted with Option PM Panel Mount kit from Greyline Instruments.

Avoid mounting the enclosure in direct sunlight to protect the electronics from damage due to overheating and condensate. In high humidity atmospheres, or where temperatures fall below freezing, Option TH Enclosure Heater and Thermostat is recommended. Seal conduit entries to prevent moisture from entering enclosure.

NEMA4X (IP66) WITH CLEAR COVER

1. Open hinged enclosure cover.
2. Insert #8 screws (supplied) through the four enclosure mounting holes to secure the enclosure to the wall or mounting stand.

Additional conduit holes can be cut in the bottom of the enclosure when required. Use a hole saw or Greenlee-type hole cutter to cut the required holes.

DO NOT make conduit/wiring entries into the top of the enclosure.

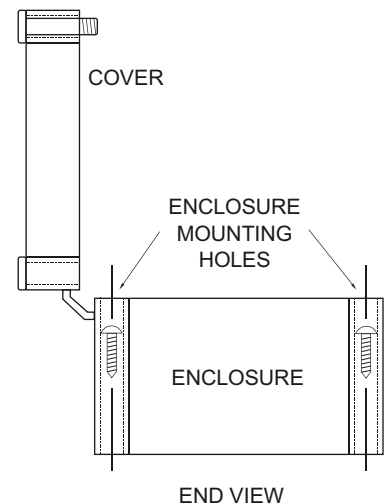

Note: This non-metallic enclosure does not automatically provide grounding between conduit connections. Grounding must be provided as part of the installation. Ground in accordance with the requirements of the National Electrical Code. System grounding is provided by connecting grounding wires from all conduit entries to the steel mounting plate or another point which provides continuity.

SYNCHRONIZATION

Synchronization may be required to prevent interference (readings with no flow or "cross talk") in applications where more than one DFM 5.0 Doppler sensor is used in close proximity. Synchronize DFM 5.0 flow meters only if sensors from separate DFM 5.0 flow meters are mounted on the same pipe.

To synchronize one or more DFM 5.0 flow meters use twisted, shielded pair cable, 22AWG or heavier. Connect SYNC + of one DFM 5.0 to the SYNC + of the next unit. And connect SYNC - of one DFM 5.0 to the SYNC - of the next unit, etc. Connect shield to Transducer GND on all units as illustrated below.

No changes in DFM 5.0 hardware setup or software are required. The instruments manage synchronization connections automatically.

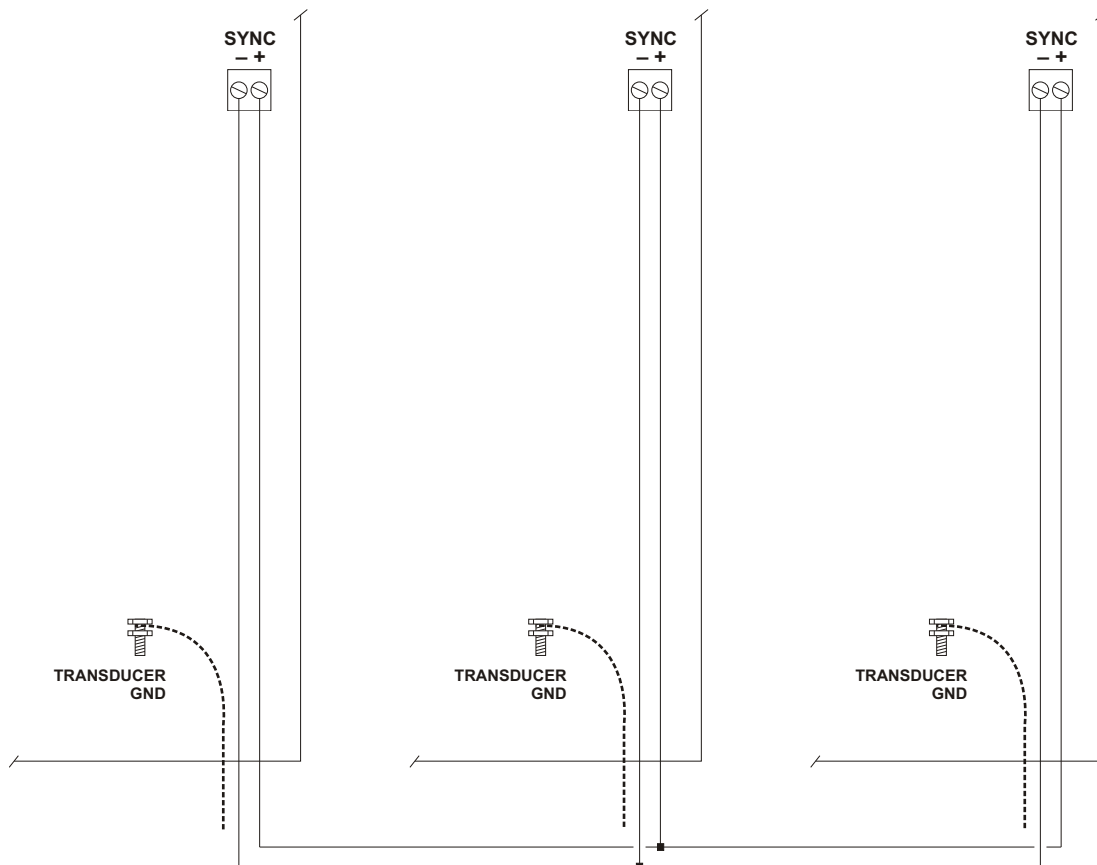

FIELD TROUBLESHOOTING

<i>Possible Causes:</i>	<i>Corrective Action:</i>
<i>METER READING LOWER THAN EXPECTED</i>	
Calibration Error	<ul style="list-style-type: none"> • Review UNITS/MODE menu and Pipe ID
Lower flow rate than expected	<ul style="list-style-type: none"> • Investigate pump/valves. Compare velocity with alternate instrument
Signal not penetrating far enough into the flow stream	<ul style="list-style-type: none"> • Relocate sensor closer to elbows or flow disturbances
Improper mounting of sensor	<ul style="list-style-type: none"> • Reinstall Sensor with careful application of Coupling Compound
Pipe is not full	<ul style="list-style-type: none"> • Remount Sensor on vertical pipe
<i>METER READING WHEN THERE IS NO FLOW</i>	
Vibration on pipe	<ul style="list-style-type: none"> • Adjust Status / Signal Cutoff setting • Install in another location
Local electrical noise	<ul style="list-style-type: none"> • Ensure all Flowmeter wiring is in METAL conduit and sensor shield is properly grounded. • Ensure correct power input Ground connection (<1 ohm resistance). • Ensure 4-20mA Shield connected to Instrument Ground stud.
Cross talk between two or more DFM 5.0 flowmeters on same pipe	<ul style="list-style-type: none"> • Refer to Synchronization instructions
Variable Speed Drive interference	<ul style="list-style-type: none"> • Follow Drive manufacturers wiring and Grounding instructions • Relocate Flowmeter electronics, Sensor and wiring away from VSD
Sensor connections incorrect	<ul style="list-style-type: none"> • Refer to Connections diagram

<i>Possible Causes:</i>	<i>Corrective Action:</i>
<i>METER READING ERRATIC</i>	
Sensor mounted too close to valve, pump or elbow	<ul style="list-style-type: none"> • Change sensor placement. Recommended 6-10 diameters from elbows, and 30 diameters from pumps, controlling valves, orifice plates, nozzles or open pipe discharge
<i>NO FLOW INDICATION</i>	
Not enough suspended particles or gases in the fluid	<ul style="list-style-type: none"> • Relocate sensor in more turbulent pipe section. Mount sensor at 12 o'clock position on horizontal pipe
Coupling compound washed out, or sensor loose on pipe	<ul style="list-style-type: none"> • Remount sensor • Use Dow Corning Silicone #4
Power interruption. No flow.	<ul style="list-style-type: none"> • Check fuse/breaker. Confirm flow
<i>METER READING TOO HIGH</i>	
Calibration error	<ul style="list-style-type: none"> • Review UNITS/MODE menu and Pipe ID
Vibration or noise on the pipeline	<ul style="list-style-type: none"> • Install in another location.
Pipe is not full	<ul style="list-style-type: none"> • Remount Sensor on vertical pipe
Nearby velocity increasing device (pump, valve, orifice plate)	<ul style="list-style-type: none"> • Relocate sensor >30 pipe diameters from velocity increasing device
Local electrical noise	<ul style="list-style-type: none"> • Ensure all Flowmeter wiring is in METAL conduit and sensor cable shield is connected to Ground stud
Variable Speed Drive interference	<ul style="list-style-type: none"> • Follow Drive manufacturers wiring and Grounding instructions • Relocate Flowmeter electronics, Sensor and wiring away from VSD

<i>Possible Causes:</i>	<i>Corrective Action:</i>
<i>METER READING DOES NOT TRACK FLOW</i>	
Sensor and GND wires reversed or not properly connected	<ul style="list-style-type: none"> • Check Sensor connections
Improper AC power input Ground	<ul style="list-style-type: none"> • Use direct connection with 12 AWG wire to nearest Ground pole (<1 ohm resistance).

COMMON QUESTIONS AND ANSWERS

The pipe vibrates. Will it affect the flow meter?

Common vibration frequencies are far lower than the sonic frequencies used by the Greyline flow meter, and will not normally affect accuracy or performance. However, applications where very weak Doppler signal is present (when sensitivity is adjusted to maximum and signal strength is low), accuracy may be affected by pipe vibration, or the flow meter may show readings under no-flow conditions. Attempt to relocate the sensor on a pipe section where vibration is reduced, or arrange pipe mounting brackets to reduce vibration at the sensor mounting location.

The flow meter must be installed in a high noise environment. Will this affect operation?

Greyline flow meters are designed to discriminate between environmental noise and the Doppler signal. High noise environments may affect the flow meter's performance where low signal strength and/or low flow velocities are being measured. Relocate the sensor in a more quiet environment if possible.

Will pipe corrosion affect accuracy of the flow meter?

Yes. Rust, loose paint etc. must be removed from the outside of the pipe to provide a clean mounting position when installing a Doppler sensor. Severe corrosion/oxidation on the inside of the pipe may prevent the Doppler signal from penetrating into the flow. If the pipe cannot be cleaned, a spool piece (PVC recommended) should be installed for sensor mounting.

What effect do pipe liners have on the flow meter?

The air gap between loose insertion liners and the pipe wall prevent the Doppler signal from entering the flow. Better results can be expected with bonded liners such as cement, epoxy or tar, however an on site test is recommended to determine if the application is suitable for a Doppler flow meter.

Why is Doppler only recommended for liquids containing suspended solids or gases?

The Doppler sensor transmits sound into the flow stream which must be reflected back to the sensor to indicate flow velocity. Gas bubbles or suspended solids act as reflectors for the Doppler signal. As a guideline, Greyline Doppler flow meters are recommended for liquids containing solids or bubbles with a minimum size of 100 microns and a minimum concentration of 75 ppm. Most applications (except potable, distilled or deionized water) will meet this minimum requirement.

Can the sensor be submerged in water?

Yes, for short periods of time or by accident, but it is not recommended for continuous operation. The sensor is constructed to withstand submersion to 10 psi without damage, but external liquid moving in contact with the sensor can be interpreted as flow and cause false readings.

What is the purpose of the Signal Strength Display?

Doppler signals of very low strength are not accepted or processed by the instrument. This feature assists in rejection of environmental noise and vibration. Use the display to evaluate signal strength in your application. Strong signals will increase in percentage to a maximum of 100%.

Can I change the length of the sensor cable?

Yes. Technological advances in Greyline Doppler design allow cable lengths up to 500 ft (152 m) with no loss of signal strength. Extended cable (Greyline Option DXC) should be installed in rigid or flexible conduit for mechanical protection. Use only Greyline shielded coaxial pair (RG174U) cable. Cable junctions should be made through a terminal block and housed in a watertight metal junction box (Greyline Option DJB). BNC coaxial connectors (TV cable type) are not recommended for cable splices.

Does the DFM 5.0 require periodic recalibration?

No. DFM 5.0 calibration does not drift over time. The solid state sensor has no moving parts to wear and affect calibration. The Doppler flow technique generates an ultrasonic signal proportional to the velocity of flow. All Greyline timing/counting circuits use crystal-controlled frequency references to eliminate any drift in the processing circuitry.

APPLICATIONS HOTLINE

For applications assistance, advice or information on any Greyline Instrument contact your Sales Representative, write to Greyline or phone the Applications Hotline below:

United States:	Tel: 315-788-9500	Fax: 315-764-0419
Canada:	Tel: 613-938-8956	Fax: 613-938-4857
Toll Free:	888-473-9546	
Email:	info@greyline.com	
Web Site:	www.greyline.com	

Greyline Instruments Inc.

Canada
16456 Sixsmith Drive
Long Sault, Ont. K0C 1P0

USA:
105 Water Street
Massena, NY 13662

PRODUCT RETURN PROCEDURE

Instruments may be returned to Greyline for service or warranty repair.

1 Obtain an RMA Number from Greyline -

Before shipping a product to the factory please contact Greyline by telephone, fax or email to obtain an RMA number (Returned Merchandise Authorization). This ensures fast service and correct billing or credit.

When you contact Greyline please have the following information available:

1. Model number / Software Version
2. Serial number
3. Date of Purchase
4. Reason for return (description of fault or modification required)
5. Your name, company name, address and phone number

2 Clean the Sensor/Product -

Important: unclean products will not be serviced and will be returned to the sender at their expense.

1. Rinse sensor and cable to remove debris.
2. If the sensor has been exposed to sewage, immerse both sensor and cable in a solution of 1 part household bleach (Javex, Clorox etc.) to 20 parts water for 5 minutes. Important: do not immerse open end of sensor cable.
3. Dry with paper towels and pack sensor and cable in a sealed plastic bag.
4. Wipe the outside of the enclosure to remove dirt or deposits.
5. Return to Greyline for service.

3 Ship to Greyline -

After obtaining an RMA number please ship the product to the appropriate address below:

Canadian and International
Customers:

Greyline Instruments Inc.
16456 Sixsmith Drive
Long Sault, Ont. K0C 1P0

RMA#

USA
Customers:

Greyline Instruments Inc.
204 150th Avenue
Madeira Beach, FL 33708

RMA#

FLOW METER DATA SHEET

<p>Greyline Instruments Inc.</p> <p><input type="checkbox"/> 16456 Sixsmith Dr., Long Sault, Ont. K0C 1P0 Tel: 613-938-8956 / Fax: 613-938-4857</p> <p><input type="checkbox"/> 105 Water Street, Massena NY 13662 Tel: 315-788-9500 / Fax: 315-764-0419</p>	<p><i>Please complete and return this form to Greyline. It is important. We use this information to check our database for performance of Greyline flow meters in similar applications, and to provide advice and recommendations to you. Thanks for your cooperation.</i></p>
<p>Contact: _____ Title/Dept.: _____</p> <p>Company: _____ Project: _____</p> <p>Address: _____</p> <p>Tel: _____ Fax: _____</p>	
<p>SENSOR:</p> <p>Model/Type: _____ Cable Length: _____</p> <p>Elec. Class: _____ Type of Pump: _____</p> <p>Distance from nearest Pump, Controlling Valve, Orifice or open Discharge: _____</p>	
<p>INSTRUMENT:</p> <p>Model/Type: _____ Power Input: _____</p> <p>Calibrated Range: _____ Indication: _____</p> <p>Operating Temp.: _____ Alarm: _____</p> <p>Enclosure Class: _____ Pulse/Unit: _____</p> <p>Elec. Class: _____ Output: _____</p>	
<p>SERVICE CONDITIONS:</p> <p>Pipe ID: _____ <input type="checkbox"/> Vertical <input type="checkbox"/> Horizontal</p> <p>Pipe Mat'l: _____ % Solids: _____</p> <p>Fluid: _____ Material Build-up: _____</p> <p>Oper. Flow: _____ Vibration: _____</p> <p>Max. Flow: _____ Max. Pressure: _____</p> <p>Min. Flow: _____ Max. Temp: _____</p>	
<p>Notes / Sketch Pipe Run:</p>	
<p>By: _____ Date: _____</p>	

LIMITED WARRANTY

Greyline Instruments warrants, to the original purchaser, its products to be free from defects in material and workmanship for a period of one year from date of invoice. Greyline will replace or repair, free of charge, any Greyline product if it has been proven to be defective within the warranty period. This warranty does not cover any expenses incurred in the removal and re-installation of the product.

If a product manufactured by Greyline should prove defective within the first year, return it freight prepaid to Greyline Instruments along with a copy of your invoice.

This warranty does not cover damages due to improper installation or handling, acts of nature, or unauthorized service. Modifications to or tampering with any part shall void this warranty. This warranty does not cover any equipment used in connection with the product or consequential damages due to a defect in the product.

All implied warranties are limited to the duration of this warranty. This is the complete warranty by Greyline and no other warranty is valid against Greyline. Some states do not allow limitations on how long an implied warranty lasts or limitation of incidental or consequential damages, so the above limitations or exclusions may not apply to you.

This warranty gives you specific legal rights, and you may also have other rights which vary from state to state.

Greyline Instruments Inc.

APPENDIX A – OPTIONS

**EXTRA SENSOR CABLE
(OPTION DXC)**

Each Greyline flow meter includes 20 ft / 6m (or 50 ft / 15 m optional) continuous shielded coaxial pair cable. Additional cable and Cable Junction Box (Option DJB) may be ordered with the Flow Meter, or the cable may be spliced and extended up to 500 ft (152m) as required during installation. No adjustment is required when the sensor cable is extended or shortened. Use only Greyline shielded coaxial pair (RG174U) cable.

Extended sensor cable should be installed in conduit for mechanical protection. Recommended installation with a metal junction box (Option DJB) is illustrated below:

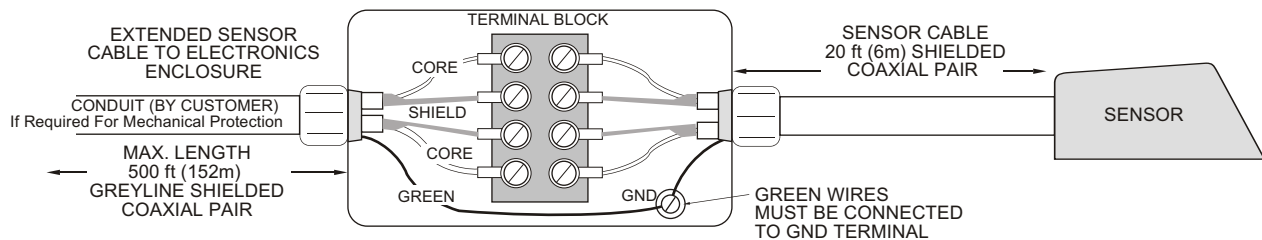

COAXIAL CABLE PREPARATION

DXC Doppler sensor cable can be cut and spliced up to a maximum length of 500 ft (152 m). Cable ends must be prepared as illustrated below.



**SENSOR CABLE JUNCTION BOX
(OPTION DJB)**

Optional Watertight steel NEMA4 Junction Boxes with terminal strips are available from Greyline Instruments.

**DIMENSIONS
OPTION DJB - JUNCTION BOX**

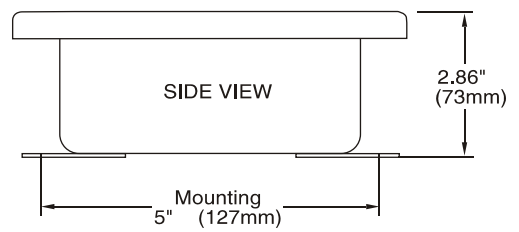
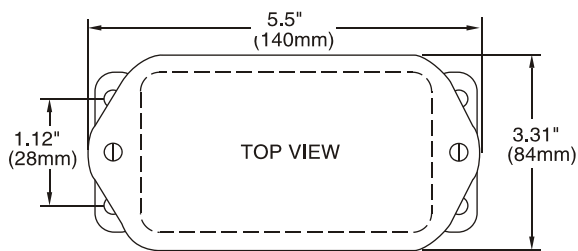

**SENSOR INTRINSIC SAFETY
(OPTION 2ISB)**

When connected through Intrinsic Safety Barriers, the Greyline Sensor Model SE4 is CSA certified for installation in a hazardous location rated:

- Class I, Groups C,D
- Class II, Groups E,F,G
- Class III

Intrinsic Safety Barriers may be ordered with the Greyline instrument and are supplied mounted in the Greyline instrument enclosure. Replacement barrier fuses (Part No. ISB- 011239) may be purchased separately. The Instrument Enclosure containing the 2ISB Intrinsic Safety Barriers must be installed in a non-hazardous location. The Sensor, connecting cable and Junction boxes may be located in the hazardous rated area.

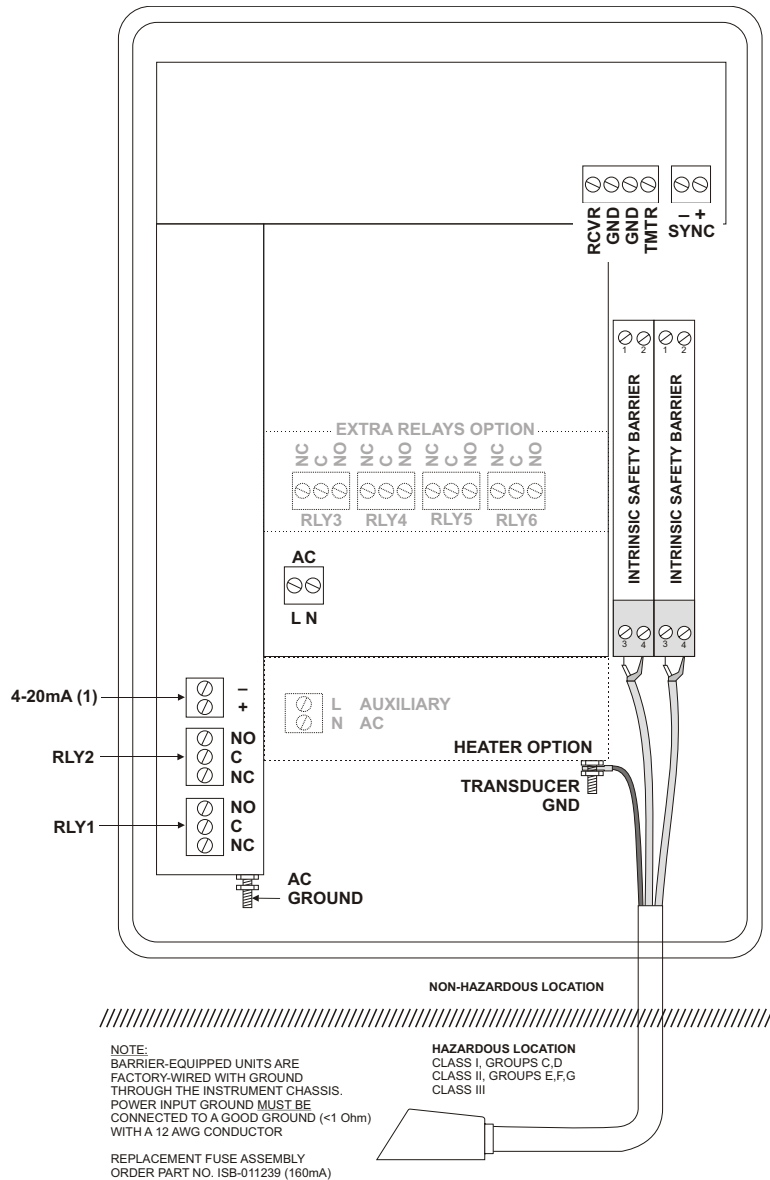

Intrinsic Safety Barrier Specifications: Certified, rated 9.3V max, 25 ohms min. (Recommended: Stahl Model 9001/02-093-390-10).

ENCLOSURE SUNSCREEN - Option SCR

Do not mount instrument electronics in direct sunlight. Overheating will reduce the life of electronic components and condensate may form during the heat/cool cycles and cause electrical shorts.

Note:

Exposure to direct sunlight can cause overheating and moisture condensation which will reduce the operating life of electronics.

Protect Instruments from direct sunlight with this iridite finished aluminum sun screen (Greyline Option SCR).

Seal conduit entries with caulking compound to further reduce moisture condensation.

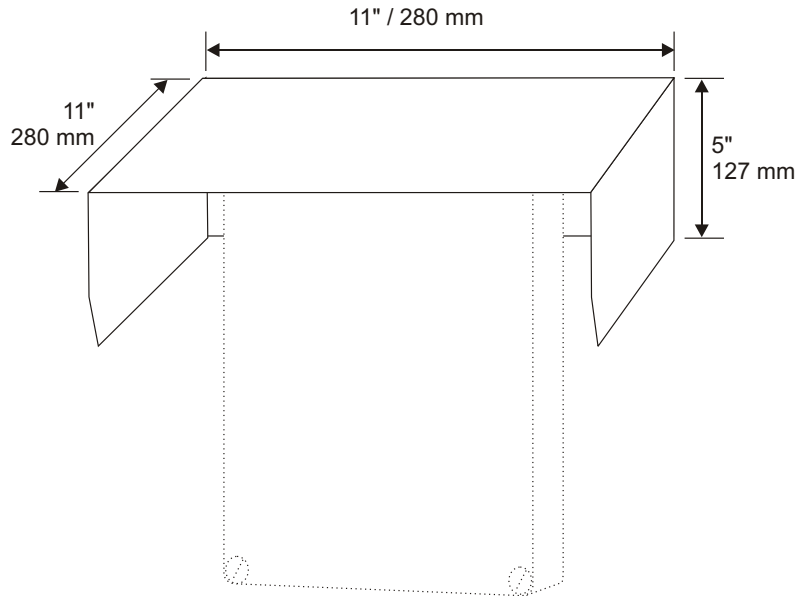

**INSERTION FLOW SENSOR
(OPTION ISE)**

Insertion Depth: 1/8th pipe inside diameter plus 3/4" (20 mm).

Orientation: Screw head marks the active face and should point upstream ±5°.

Average Flow Rate: Before permanent tightening of swage lock fitting, the probe can be inserted to variable depths to determine the flow profile. Theoretical average flow occurs at 1/8 pipe diameter.

Installation Procedure: Install a 1" NPT Female Nipple on the Pipe. Insert probe. Tighten swage lock until it just grips the Probe - then tighten 3/4 of a turn. Do not use above 100 psi.

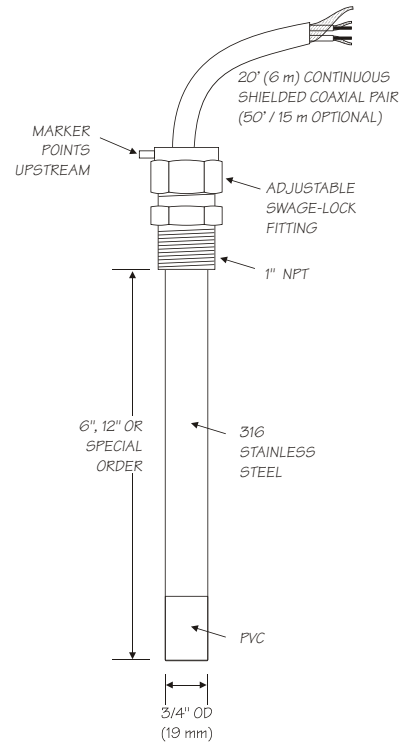

**HIGH TEMPERATURE SENSOR
(OPTION SE3H)**

Mount with coupling compound and stainless steel pipe clamp (supplied). Protect Sensor cable from contact with hot pipes.

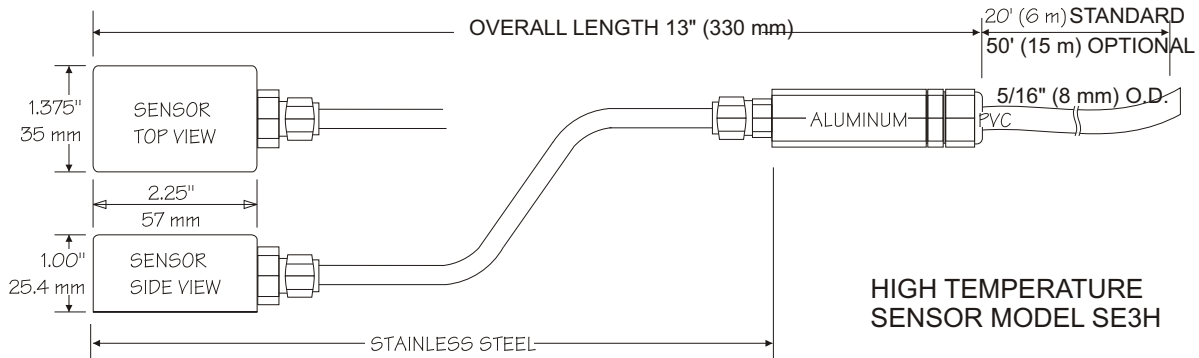

SE3H Specifications:

- Operating Temperature: -40° to 302°F (-40° to 150°C)
- Minimum Pipe Diameter: 0.5" (12.5 mm) ID, 0.6" (15 mm) OD
- Maximum Pipe Diameter: 180" (4.5 m) O.D.
- Operating Frequency: 640 KHz
- Exposed Materials: stainless steel with epoxy face
- Sensor Cable: 20 ft (6 m) RG174U shielded coaxial pair

```

--Data Logging-----
>Log Site ID      00
                  99
Mode              Flow
                  Velocity
Set Date Feb 18/2008
              Mar 19/2009
Set Time  11:27:40
              12:28:41
Interval   10sec
              60min
              30min
              10min
              5min
              2min
              1min
              30sec
Reset Log   NO
              YES
  
```

DATA LOGGING (Optional)

Setup

Select Data Logging from Menu Selections.

- Log Site ID** Enter a number from 00 to 99. The site ID will become part of the downloaded file name to help distinguish downloads from different instruments.
- Mode** Select Velocity (e.g. ft/sec or m/sec). Flow (e.g. USGPM or l/sec). Press ✓ to store the setting.

Set Date Press ↑ or ↓ to scroll and select Month, Day and Year.

Set Time Press ↑ or ↓ to select the current time in Hours, Minutes and Seconds.

Interval Press ↑ or ↓ to select the logging interval. Flow rate reading will be stored at each time interval.

RETRIEVE LOG FILE

Plug a USB Flash Memory Drive (not supplied by Greyline) into the USB output cable from the instrument. The instrument display will show the message `Downloading` until the log file is transferred to the memory card and then display `Completed`. The USB flash drive may be removed.

Download file names will appear in this format:



Tag is set according to the Log Site ID entered in the instrument Data Logging menu.

Download letter will be A for the first download from an instrument. B for the second, then C etc. At the letter Z a – character will appear indicating that the maximum number of downloads for that instrument are on the USB flash drive. Older files can be erased or moved from the flash memory drive or a new memory drive can be used.

OPENING LOG FILES

Install Greyline Logger on your PC or laptop. Refer to the Help menu in the program for detailed instructions.

Select File/Open/Instrument Log (.log) to open the log file from your USB flash drive.

SPECIFICATIONS

- Flow Rate Range:** -40 to -0.25 ft/sec, +0.25 to +40 ft/sec (-12.2 to -0.076 m/sec, +0.076 to +12.2 m/sec,) in most applications
- Pipe Size:** Any pipe ID from ½ " to 180" (12.7 mm to 4.5 m)
- Accuracy:** ±2% of full scale. Requires solids or bubbles minimum size of 100 microns, minimum concentration 75 ppm. Repeatability: ±0.1%, Linearity ±0.5% of full scale
- Displays:** White, backlit matrix - displays flow rate, totalizer, relay states, operating mode and calibration menu
- Calibration:** built-in 5-key calibrator with English, French or Spanish language selection
- Power Input:** 100-240VAC, 50/60 Hz (see Options), 3 Watts maximum (with standard features)
- Output:** Isolated 4-20mA (1000 ohm load max.)
- Control Relays:** Qty 2, rated 5 amp SPDT, programmable flow alarm and/or proportional pulse
- Enclosure:** watertight, dust tight NEMA4X (IP66) fiberglass with a clear shatter-proof face
- Electronics Operating Temp:** -10° to 140°F (-23° to 60°C)
- Sensitivity:** adjustable. Damping: adjustable
- Electrical Surge Protection:** Sensor, 4-20mA output and AC power input
- Shipping Weight:** 14 lbs (6.3 kg)

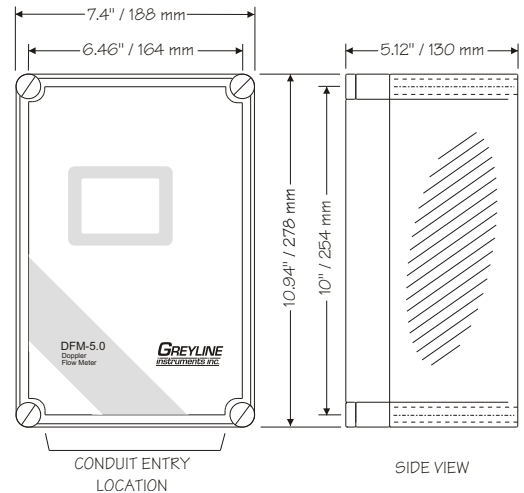

SE4 Doppler Sensor

- Minimum Pipe Diameter:** 0.5" (12.5 mm) ID, 0.6" (15 mm) OD
- Maximum Pipe Diameter:** 180" (4.5 m) ID
- Operating Temperature:** -40° to 200°F (-40° to 93°C)
- Operating Frequency:** 1.2 MHz
- Sensor Housing:** Stainless Steel
- Sensor Cable:** 20 ft. (6 m) shielded coaxial pair (RG174U)
Optional 50 ft (15 m) or 100 ft (30 m) continuous
- Submersion Rating:** Withstands accidental submersion pressure up to 10 psi (0.7 Bar)
- Hazardous Locations:** Pending - Rated for sensor and cable installation in Class I, Div. I,II, Groups C,D,E,F,G
Hazardous locations with optional Intrinsic Safety Barriers

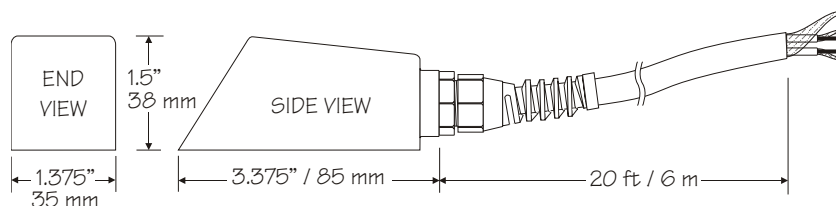

APPENDIX B - CONVERSION TABLE

CONVERSION GUIDE		
FROM	TO	MULTIPLY BY
US GALLONS	CUBIC FEET	0.1337
US GALLONS	IMPERIAL GALS	0.8327
US GALLONS	LITRES	3.785
US GALLONS	CUBIC METERS	0.003785
LITRES/SEC	GPM	15.85
LITRES	CUBIC METERS	0.001
BARRELS	US GALLONS	42
BARRELS	IMPERIAL GALS	34.9726
BARRELS	LITRES	158.9886
INCHES	MM	25.4
DEGREES F	DEGREES C	$(^{\circ}\text{F}-32) \times 0.556$
POUNDS	KILOGRAMS	0.453
PSI	BAR	0.0676
FOOT ²	METER ²	0.0929

Note: BARRELS are U.S. oil barrels.

PIPE CHARTS

Carbon Steel & PVC Pipe

Pipe Size	Pipe O.D.	Standard Schedule 40		Extra Heavy Schedule 80		Dbl. Extra Heavy		Schedule 10		Schedule 20		Schedule 30		Schedule 40	
		I.D.	WALL	I.D.	WALL	I.D.	WALL	I.D.	WALL	I.D.	WALL	I.D.	WALL	I.D.	WALL
1/2	.840	.622	.109	.546	.147	.252	.294							.622	.109
3/4	1.050	.824	.113	.742	.154	.434	.308							.824	.113
1	1.315	1.049	.133	.957	.179	.599	.358							1.049	.133
1 1/4	1.660	1.380	.140	1.278	.191	.896	.382							1.380	.140
1 1/2	1.900	1.610	.145	1.500	.200	1.100	.400							1.610	.145
2	2.375	2.067	.154	1.939	.218	1.503	.436							2.067	.154
2 1/2	2.875	2.469	.203	2.323	.276	1.771	.552							2.469	.203
3	3.500	3.068	.216	2.900	.300	2.300	.600							3.068	.216
3 1/2	4.000	3.548	.226	3.364	.318	2.728	.636							3.548	.226
4	4.500	4.026	.237	3.826	.337	3.152	.674							4.026	.237
5	5.563	5.047	.258	4.813	.375	4.063	.750							5.047	.258
6	6.625	6.065	.280	5.761	.432	4.897	.864							6.065	.280
8	8.625	7.981	.322	7.625	.500	6.875	.875			8.125	.250	8.071	.277	7.981	.322
10	10.750	10.020	.365	9.750	.500	8.750	1.000			10.250	.250	10.136	.307	10.020	.365
12	12.750	12.000	.375	11.750	.500	10.750	1.000			12.250	.250	12.090	.330	11.938	.406
14	14.000	13.250	.375	13.000	.500			13.500	.250	13.376	.312	13.250	.375	13.124	.438
16	16.000	15.250	.375	15.000	.500			15.500	.250	15.376	.312	15.250	.375	15.000	.500
18	18.000	17.250	.375	17.000	.500			17.500	.250	17.376	.312	17.124	.438	16.876	.562
20	20.000	19.250	.375	19.000	.500			19.500	.250	19.250	.375	19.000	.500	18.814	.593
22	22.000	21.250	.375	21.000	.500			21.500	.250	21.250	.375	21.000	.500		
24	24.000	23.250	.375	23.000	.500			23.500	.250	23.250	.375	22.876	.562	22.626	.687
26	26.000	25.250	.375	25.000	.500			25.376	.312	25.000	.500				
28	28.000	27.250	.375	27.000	.500			27.376	.312	27.000	.500	26.750	.625		
30	30.000	29.250	.375	29.000	.500			29.376	.312	29.000	.500	28.750	.625		
32	32.000	31.250	.375	31.000	.500			31.376	.312	31.000	.500	30.750	.625		
34	34.000	33.250	.375	33.000	.500			33.376	.312	33.000	.500	32.750	.625		
36	36.000	35.250	.375	35.000	.500			35.376	.312	35.000	.500	34.750	.625		
42	42.000	41.250	.375	41.000	.500					41.000	.500	40.750	.625		

Ductile Iron Pipe - Standard Classes

Size INCH	OUTSIDE DIA. INCH	Class 50		Class 51		Class 52		Class 53		Class 54		Class 55		Class 56		CEMENT LINING	
		WALL	I.D.	WALL	I.D.	WALL	I.D.	WALL	I.D.	WALL	I.D.	WALL	I.D.	WALL	I.D.	**STD THICKNESS	**DOUBLE THICKNESS
3	3.96			0.25	3.46	0.28	3.40	0.31	3.34	0.34	3.28	0.37	3.22	0.41	3.14		
4	4.80			0.26	4.28	0.29	4.22	0.32	4.16	0.35	4.10	0.38	4.04	0.44	3.93		
6	6.90	0.25	6.40	0.28	6.34	0.31	6.28	0.34	6.22	0.37	6.16	0.40	6.10	0.43	6.04	.125	.250
8	9.05	0.27	8.51	0.30	8.45	0.33	8.39	0.36	8.33	0.39	8.27	0.42	8.21	0.45	8.15		
10	11.10	0.39	10.32	0.32	10.46	0.35	10.40	0.38	10.34	0.41	10.28	0.44	10.22	0.47	10.16		
12	13.20	0.31	12.58	0.34	12.52	0.37	12.46	0.40	12.40	0.43	12.34	0.46	12.28	0.49	12.22		
14	15.30	0.33	14.64	0.36	14.58	0.39	14.52	0.42	14.46	0.45	14.40	0.48	14.34	0.51	14.28		
16	17.40	0.34	16.72	0.37	16.66	0.40	16.60	0.43	16.54	0.46	16.48	0.49	16.42	0.52	16.36		
18	19.50	0.35	18.80	0.38	18.74	0.41	18.68	0.44	18.62	0.47	18.56	0.50	18.50	0.53	18.44	.1875	.375
20	21.60	0.36	20.88	0.39	20.82	0.42	20.76	0.45	20.70	0.48	20.64	0.51	20.58	0.54	20.52		
24	25.80	0.38	25.04	0.41	24.98	0.44	24.92	0.47	24.86	0.50	24.80	0.53	24.74	0.56	24.68		
30	32.00	0.39	31.22	0.43	31.14	0.47	31.06	0.51	30.98	0.55	30.90	0.59	30.82	0.63	30.74		
36	38.30	0.43	37.44	0.48	37.34	0.62	37.06	0.58	37.14	0.63	37.04	0.68	36.94	0.73	36.84		
42	44.50	0.47	43.56	0.53	43.44	0.59	43.32	0.65	43.20	0.71	43.08	0.77	42.96	0.83	42.84	.250	.500
48	50.80	0.51	49.78	0.58	49.64	0.65	49.50	0.72	49.36	0.79	49.22	0.86	49.08	0.93	48.94		
54	57.10	0.57	55.96	0.65	55.80	0.73	55.64	0.81	55.48	0.89	55.32	0.97	55.16	1.05	55.00		

**REDUCE I.D. BY DIMENSION SHOWN

Stainless Steel, Hastelloy "C" & Titanium Pipe

Pipe Size	Pipe O.D.	Schedule 5 S (a)		Schedule 10 S (a)		Schedule 40 S		Schedule 80 S	
		I.D.	WALL	I.D.	WALL	I.D.	WALL	I.D.	WALL
½	.840	.710	.065	.674	.083	.622	.109	.546	.147
¼	1.050	.920	.065	.884	.083	.824	.113	.742	.154
1	1.315	1.185	.065	1.097	.109	1.049	.133	.957	.179
1¼	1.660	1.530	.065	1.442	.109	1.380	.140	1.278	.191
1½	1.900	1.770	.065	1.682	.109	1.610	.145	1.500	.200
2	2.375	2.245	.065	2.157	.109	2.067	.154	1.939	.218
2½	2.875	2.709	.083	2.635	.120	2.469	.203	2.323	.276
3	3.500	3.334	.083	3.260	.120	3.068	.216	2.900	.300
3½	4.000	3.834	.083	3.760	.120	3.548	.226	3.364	.318
4	4.500	4.334	.083	4.260	.120	4.026	.237	3.826	.337
5	5.563	5.345	.109	5.295	.134	5.047	.258	4.813	.375
6	6.625	6.407	.109	6.357	.134	6.065	.280	5.761	.432
8	8.625	8.407	.109	8.329	.148	7.981	.322	7.625	.500
10	10.750	10.482	.134	10.420	.165	10.020	.365	9.750	.500
12	12.750	12.438	.156	12.390	.180	12.000	.375	11.750	.500
14	14.000	13.688	.156	13.624	.188				
16	16.000	15.670	.165	15.624	.188				
18	18.000	17.670	.165	17.624	.188				
20	20.000	19.634	.188	19.564	.218				
22	22.000	21.624	.188	21.564	.218				
24	24.000	23.563	.218	23.500	.250				

Pipe Size	Pipe O.D.	Schedule 60		Schedule 80		Schedule 100		Schedule 120		Schedule 140		Schedule 160	
		I.D.	WALL	I.D.	WALL	I.D.	WALL	I.D.	WALL	I.D.	WALL	I.D.	WALL
½	.840			.546	.147							.466	.187
¼	1.050			.742	.154							.614	.218
1	1.315			.957	.179							.815	.250
1¼	1.660			1.278	.191							1.160	.250
1½	1.900			1.500	.200							1.338	.281
2	2.375			1.939	.218							1.689	.343
2½	2.875			2.323	.276							2.125	.375
3	3.500			2.900	.300							2.624	.438
3½	4.000			3.364	.318								
4	4.500			3.826	.337			3.624	.438			3.438	.531
5	5.563			4.813	.375			4.563	.500			4.313	.625
6	6.625			5.761	.432			5.501	.562			5.189	.718
8	8.625	7.813	.406	7.625	.500	7.439	.593	7.189	.718	7.001	.812	6.813	.906
10	10.750	9.750	.500	9.564	.593	9.314	.718	9.064	.843	8.750	1.000	8.500	1.125
12	12.750	11.626	.562	11.376	.687	11.064	.843	10.750	1.000	10.500	1.125	10.126	1.312
14	14.000	12.814	.593	12.500	.750	12.126	.937	11.814	1.093	11.500	1.250	11.188	1.406
16	16.000	14.688	.656	14.314	.843	13.938	1.031	13.564	1.218	13.124	1.438	12.814	1.593
18	18.000	16.500	.750	16.126	.937	15.688	1.156	15.250	1.375	14.876	1.562	14.438	1.781
20	20.000	18.376	.812	17.938	1.031	17.438	1.281	17.000	1.500	16.500	1.750	16.064	1.968
22	22.000	20.250	.875	19.750	1.125	19.250	1.375	18.750	1.625	18.250	1.875	17.750	2.125
24	24.000	22.064	.968	21.564	1.218	20.938	1.531	20.376	1.812	19.876	2.062	19.314	2.343

Cast Iron Pipe - ASA Standard

Pipe Size	Pipe O.D.	Class 50		Class 100		Class 150		Class 200		Class 250		Class 300		Class 350	
		WALL	I.D.	WALL	I.D.	WALL	I.D.	WALL	I.D.	WALL	I.D.	WALL	I.D.	WALL	I.D.
3	3.96	0.32	3.32	0.32	3.32	0.32	3.32	0.32	3.32	0.32	3.32	0.32	3.32	0.32	3.32
4	4.80	0.35	4.10	0.35	4.10	0.35	4.10	0.35	4.10	0.35	4.10	0.35	4.10	0.35	4.10
6	6.90	0.38	6.14	0.38	6.14	0.38	6.14	0.38	6.14	0.38	6.14	0.38	6.14	0.38	6.14
8	9.05	0.41	8.23	0.41	8.23	0.41	8.23	0.41	8.23	0.41	8.23	0.41	8.23	0.41	8.23
10	11.10	0.44	10.22	0.44	10.22	0.44	10.22	0.44	10.22	0.44	10.22	0.48	10.14	0.52	10.06
12	13.20	0.48	12.24	0.48	12.24	0.48	12.24	0.48	12.24	0.52	12.16	0.52	12.16	0.56	12.08
14	15.30	0.48	14.34	0.51	14.28	0.51	14.28	0.55	14.20	0.59	14.12	0.59	14.12	0.64	14.02
16	17.40	0.54	16.32	0.54	16.32	0.54	16.32	0.58	16.24	0.63	16.14	0.68	16.04	0.68	16.04
18	19.50	0.54	18.42	0.58	18.34	0.58	18.34	0.63	18.24	0.68	18.14	0.73	18.04	0.79	17.92
20	21.60	0.57	20.46	0.62	20.36	0.62	20.36	0.67	20.26	0.72	20.16	0.78	20.04	0.84	19.92
24	25.80	0.63	24.54	0.68	24.44	0.73	24.34	0.79	24.22	0.79	24.22	0.85	24.10	0.92	23.96

Cast Iron Pipe - AWWA Standard

Pipe Size	Class A 100 Ft. 43 PSIG			Class B 200 Ft. 86 PSIG			Class C 300 Ft. 130 PSIG			Class D 400 Ft. 173 PSIG		
	O.D.	WALL	I.D.	O.D.	WALL	I.D.	O.D.	WALL	I.D.	O.D.	WALL	I.D.
3	3.80	0.39	3.02	3.96	0.42	3.12	3.96	0.45	3.06	3.96	0.48	3.00
4	4.80	0.42	3.96	5.00	0.45	4.10	5.00	0.48	4.04	5.00	0.52	3.96
6	6.90	0.44	6.02	7.10	0.48	6.14	7.10	0.51	6.08	7.10	0.55	6.00
8	9.05	0.46	8.13	9.05	0.51	8.03	9.30	0.56	8.18	9.30	0.60	8.10
10	11.10	0.50	10.10	11.10	0.57	9.96	11.40	0.62	10.16	11.40	0.68	10.04
12	13.20	0.54	12.12	13.20	0.62	11.96	13.50	0.68	12.14	13.50	0.75	12.00
14	15.30	0.57	14.16	15.30	0.66	13.98	15.65	0.74	14.17	15.65	0.82	14.01
16	17.40	0.60	16.20	17.40	0.70	16.00	17.80	0.80	16.20	17.80	0.89	16.02
18	19.50	0.64	18.22	19.50	0.75	18.00	19.92	0.87	18.18	19.92	0.96	18.00
20	21.60	0.67	20.26	21.60	0.80	20.00	22.06	0.92	20.22	22.06	1.03	20.00
24	25.80	0.76	24.28	25.80	0.89	24.02	26.32	1.04	24.22	26.32	1.16	24.00
30	31.74	0.88	29.98	32.00	1.03	29.94	32.40	1.20	30.00	32.74	1.37	30.00
36	37.96	0.99	35.98	38.30	1.15	36.00	38.70	1.36	39.98	39.16	1.58	36.00
42	44.20	1.10	42.00	44.50	1.28	41.94	45.10	1.54	42.02	45.58	1.78	42.02
48	50.50	1.26	47.98	50.80	1.42	47.96	51.40	1.71	47.98	51.98	1.96	48.06
54	56.66	1.35	53.96	57.10	1.55	54.00	57.80	1.90	54.00	58.40	2.23	53.94
60	62.80	1.39	60.02	63.40	1.67	60.06	64.20	2.00	60.20	64.82	2.38	60.06
72	75.34	1.62	72.10	76.00	1.95	72.10	76.88	2.39	72.10			
84	87.54	1.72	84.10	88.54	2.22	84.10						

Pipe Size	Class E 500 Ft. 217 PSIG			Class F 600 Ft. 260 PSIG			Class G 700 Ft. 304 PSIG			Class H 800 Ft. 347 PSIG		
	O.D.	WALL	I.D.	O.D.	WALL	I.D.	O.D.	WALL	I.D.	O.D.	WALL	I.D.
6	7.22	0.58	6.06	7.22	0.61	6.00	7.38	0.65	6.08	7.38	0.69	6.00
8	9.42	0.66	8.10	9.42	0.71	8.00	9.60	0.75	8.10	9.60	0.80	8.00
10	11.60	0.74	10.12	11.60	0.80	10.00	11.84	0.86	10.12	11.84	0.92	10.00
12	13.78	0.82	12.14	13.78	0.89	12.00	14.08	0.97	12.14	14.08	1.04	12.00
14	15.98	0.90	14.18	15.98	0.99	14.00	16.32	1.07	14.18	16.32	1.16	14.00
16	18.16	0.98	16.20	18.16	1.08	16.00	18.54	1.18	16.18	18.54	1.27	16.00
18	20.34	1.07	18.20	20.34	1.17	18.00	20.78	1.28	18.22	20.78	1.39	18.00
20	22.54	1.15	20.24	22.54	1.27	20.00	23.02	1.39	20.24	23.02	1.51	20.00
24	26.90	1.31	24.28	26.90	1.45	24.00	27.76	1.75	24.26	27.76	1.88	24.00
30	33.10	1.55	30.00	33.46	1.73	30.00						
36	39.60	1.80	36.00	40.04	2.02	36.00						