



ORIGA T100 / R100

User Manual



T100 Transmitter

The ORIGA T100 is an easy to use Frequency Hopping Spread Spectrum weatherproof Transmitter with eight function controls. The green [Power] button can act as a ninth function control when the Transmitter is in use. Each T100 uses a unique ID code to ensure that no two systems will conflict on a job site. It also features five configuration modes that control how the system will power up and shut down.

R100 Receiver

The R100 is an eight-output Receiver designed to be powered from a 12VDC or a 24VDC system. The R100 Receiver has an EN418 compliant E-Stop relay that allows a safe emergency shutdown of power to the outputs and external circuits. The eight function outputs may be configured for a variety of switching modes. The R100 Receiver also features a momentary ninth function and a "Link" output (output 10) that operates in one of five modes. The R100 Receiver is available with either an internal or an external antenna. For wiring details, refer to the **R100 Receiver Wiring Diagram** on the third page.

Preparing the ORIGA System

1) Power the R100 Receiver

Refer to the **R100 Receiver Wiring Diagram** on the third page of this manual to correctly power the Receiver.

2) Power the T100 Transmitter

Batteries are installed in the Transmitter by removing the battery cover using a slotted screwdriver and inserting 4 "AA" alkaline batteries. Orientation of the batteries is embossed inside the battery housing.

Turn on the Transmitter by pressing the green [Power] button.
Turn off the Transmitter by pressing the red [E-Stop] button.

3) Test the Transmitter / Receiver Link

In order to determine if there is a Link between the Transmitter and Receiver:

- 1) Ensure that the Transmitter is off and supply power to the Receiver. Three lights will come on: the green (Status) light, the (E-Stop) light and the left (+) light in the center of the unit.
- 2) Turn on the Transmitter by pressing and releasing the green [Power] button. The yellow (Active) light will come on and begin flashing. If both the yellow (Active) light on the Transmitter and the green (Link) light on the Receiver are flashing, a Link between the two exists.

The ORIGA System is now ready for use.

If the Transmitter's yellow (Active) light does not flash, check the battery orientation.
If the Receiver's green (Link) light does not flash, then it may be necessary to download the ID Code as explained below.

Download ID Code (Use in case of Link Test failure)

Follow these steps to establish a Link between the Receiver and Transmitter by downloading the Transmitter's unique ID Code into the Receiver
NOTE: It is necessary to download the ID Code when replacing either the Transmitter or the Receiver.

- 1) Ensure that the Transmitter is off and supply power to the Receiver. Three lights will come on: the green (Status) light, the (E-Stop) light and the left (+) light in the center of the unit.
- 2) Turn on the Transmitter by pressing and holding the red [E-Stop] button and the green [Power] button, and then releasing first the red [E-Stop] button and then the green [Power] button. This will power up the Transmitter into Download Mode. The yellow (Active) light will begin flashing slowly (once per second).
- 3) Press and hold the blue [SETUP] button on the Receiver. The yellow (Setup) light will flash slowly. Continue to hold the blue [SETUP] button until the yellow (Setup) light starts flashing rapidly (approximately 5 seconds) and then release; it will now remain on steady. NOTE: If left idle in setup mode for over 30 seconds, the Receiver will time out, indicated by the red (Status) light flashing rapidly. Cycle the power off and on again and restart the procedure.
- 4) Press and release the green [Power] button on the Transmitter to start sending the ID Code and the Configuration Information to the Receiver. On the Transmitter, the red (Battery) light will come on and the yellow (Active) light will flash rapidly; on the Receiver, the (Link) light will flash. Once the ID Code has been downloaded, the red (Battery) light and the yellow (Active) light on the Transmitter will go out. The (Link) light on the Receiver will go out and the green (Status) light will begin flashing.
- 5) Cycle the power off and on again on the Receiver and power up the Transmitter. The two units will now be linked.



R100 Receiver Wiring Diagram

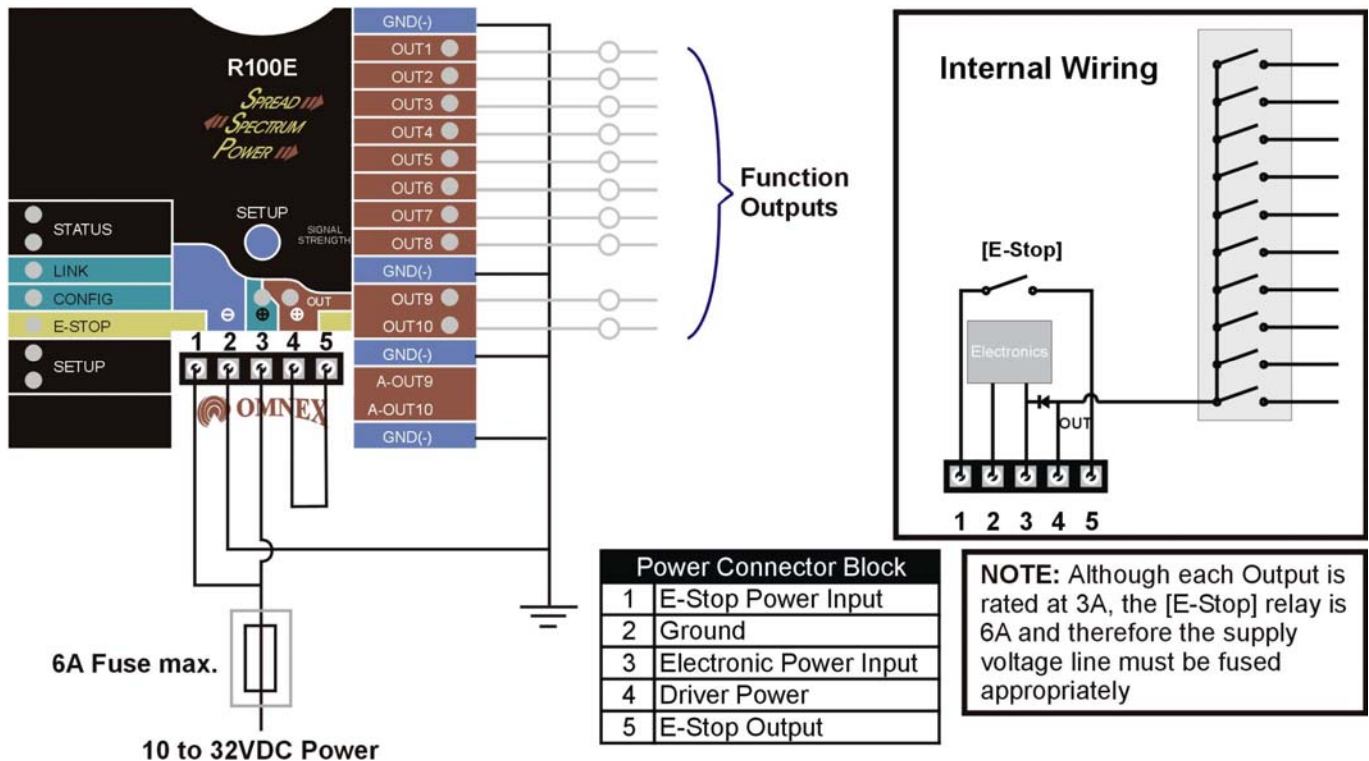

Diagnostics

R100 Receiver Indicator Lights	
green (Status)	Solid- Output status is correct Flashing- Wiring error in outputs
green (Status) and red (Status)	Flashing Together- No power available to outputs
red (Status)	Status Alert
(Link)	Transmitter and Receiver are linked
(Config)	Receiver is in Configuration Check Mode
(E-Stop)	E-Stop relay is open when light is on and closed when off
(E-Stop) and red (Status)	(E-Stop) flashing with red (Status) solid- E-Stop sub-system failure
yellow (Setup)	Receiver is in Setup Mode
red (Setup)	Solid- Configuration data corrupted Flashing- Configuration download failure
left (+)	Power to electronics
right (+)	Power available to outputs
(Outputs 1-10)	Active outputs

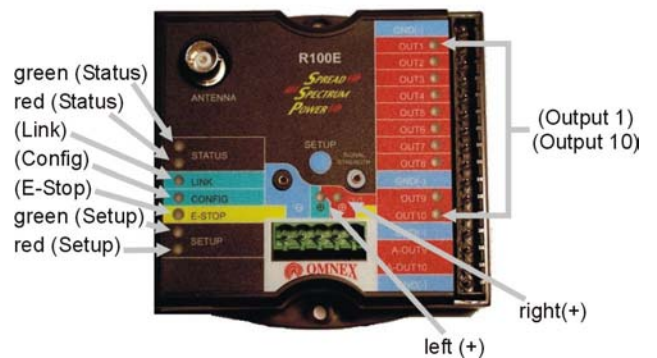

T100 Transmitter Indicator Lights	
yellow (Active)	Flashes during normal operation. Will remain on momentarily whenever a function button is pressed or released Slow Flash- Download Mode
red (Battery)	Slow Flash- low battery Fast Flash (10 seconds)- Transmitter failure
yellow (Active) and red (Battery)	Fast Flash together- Configuration Mode Slow Flash together- Stuck button detected

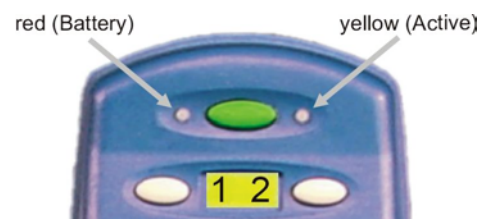

Installation Considerations

There are a number of considerations that should be made when installing the ORIGA T100 / R100 system. These include mounting location, power supply, wiring and filtering of undesired transients.

Mounting and Installation

The Receiver can be mounted by fastening two #8 screws with flat washers through the two mounting holes in the unit's enclosure. When mounting, ensure that the Receiver is oriented so that the text is reading right.

When selecting a mounting point for the Receiver, it is recommended that the location require only a minimal length of wiring to connect it to the control panel, that it will be in a visible area where it has good exposure to the operator and that it is mounted on a surface that is protected from the weather and sustains minimal vibration. It is also recommended that the Receiver (or the external antenna, if applicable) have the best possible line of sight with the Transmitter.

If custom work requires that welding be performed, be sure to observe proper grounding practices before welding and make sure all connectors to the Receiver have been disconnected.

Power Connections and Wiring

Whenever a power connection is made to an electronic device, it is a good practice to make both the Power (+) and Ground (-) connections directly to the Battery and avoid connecting the power from the charging side of existing wiring or making use of existing "ACC" or other peripheral connection points.

Make sure that wire of sufficient gauge and insulator type is used when connecting the outputs of the Receiver to the control panel. Observe any component manufacturer's instructions and recommendations for proper integration of their product. This includes the power ratings and requirements of such components as relays, valves, solenoids, etc.

Filtering and Noise Suppression

Whenever a solenoid or electromagnetic switch is controlled by the Receiver, it is a good practice to install a Diode across its terminals to ensure that surges and spikes do not continue back into the circuit. Appropriate 36V Bi-directional Diodes Kits can be ordered under the OMNEX part number "AKIT-2492-01".

OMNEX Replaceable Parts & Accessories

Part	OMNEX Part Number	Description
Batteries	B0010	4 x AA alkaline
Leather Pouch	FMEC-2234-01	see illustration below
Belt Clip	AKIT-2428-03	see illustration below
Magnets	AKIT-2428-01	see illustration below
Keypad Label T100	FLBL-1726-01	see illustration below
Bipolar Diode Kit	AKIT-2492-01	36V, Bi-directional, Motorola P6KE36CA
Dash Cradle	Call OMNEX	see illustration below



Dash Cradle



Leather Pouch



Belt Clip

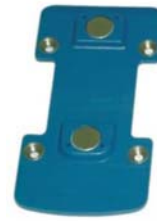

Magnets

FCC Rules and Compliance

This device complies with Part 15 of the FCC Rules. Operation is subject to the following two conditions: (1) This device may not cause harmful interference, and (2) this device must accept any interference received, including interference that may cause undesired operation.

FCC Part 15.247
 ISC RSS 210

Warranty

OMNEX Control Systems Inc. warrants to the original purchaser that the OMNEX products are free from defects in materials and workmanship under normal use and service for a period of ONE YEAR, parts (EXCLUDING: SWITCHES, CRYSTALS, OR PARTS SUBJECT TO UNAUTHORIZED REPAIR OR MODIFICATION) and labor from the date of delivery as evidenced by a copy of the receipt. OMNEX's entire liability and your exclusive remedy shall be, at OMNEX's option, either the (a) repair or (b) replacement of the OMNEX product which is returned within the warranty period to OMNEX freight collect by the OMNEX APPROVED carrier with a copy of the purchase receipt and with the return authorization of OMNEX. If failure has resulted from accident, abuse or misapplication, OMNEX shall have no responsibility to repair or replace the product under warranty. In no event shall OMNEX be responsible for incidental or consequential damage caused by defects in its products, whether such damage occurs or is discovered before or after replacement or repair and whether or not such damage is caused by the negligence of OMNEX Control Systems Inc.