

# DPM 912

## 3½ Digit LCD 2-Wire Voltmeter with LED Backlighting

### FEATURES

- 19mm (0.75") Digit Height
- 2-wire operation
- 3 to 60V operation
- Screw terminal connection
- IP-67 bezel available (BEZ 900-IP)

The DPM 912 is a large 3½ Digit LCD Voltmeter. The signal being measured is also used to power the meter, including the backlight. The meter features a 3 to 60V measurement range, with a resolution of 10mV between 3.00 and 19.99V and 100mV between 20.0 and 60.0V. When the voltage drops below 3V, LO is displayed (down to 2.8V, when the display will turn off). 'HI' is displayed when the voltage goes above 60V.

Screw terminals allow for quick and easy connection. The meter is housed in a robust carrier which can be bolted in place or panel mounted using the low profile bezel and clips provided. An IP67 / NEMA 4X bezel is also available for protection against dust and moisture.

### ORDERING INFORMATION

Standard Instrument (panel meter, fixing kit, data sheet)	DPM 912
IP-67 Metal Alloy Bezel	BEZ 900-IP



### SPECIFICATIONS

	Minimum	Typical	Maximum	Unit
Accuracy (overall error)		0.05	0.1	% (±1 count)
Linearity			±1	count
Sample rate		3		samples/second
Operating temperature range	0		50	°C (°F)
Temperature stability		100		ppm/°C
Supply voltage	3		60	V
Supply current	8		100	mA
Input leakage current (VIN = 0V)			10	µA

### PIN FUNCTIONS

V+	Positive power supply connection
0V	Negative power supply connection

### LCD SYMBOLS

LO	Supply Voltage is below 3V (Note: Below 2.8V display will turn off)
HI	Supply Voltage is above 60V (Note: Do not exceed 60V)

### TYPICAL SUPPLY CURRENT

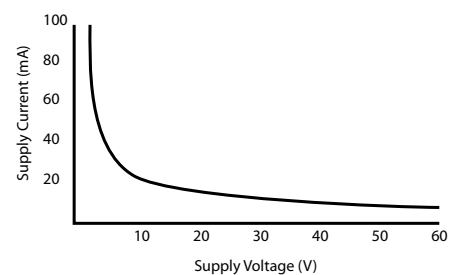

# DPM 912

## 3½ Digit LCD 2-Wire Voltmeter with LED Backlighting

### DIMENSIONS

All dimensions in mm (inches)

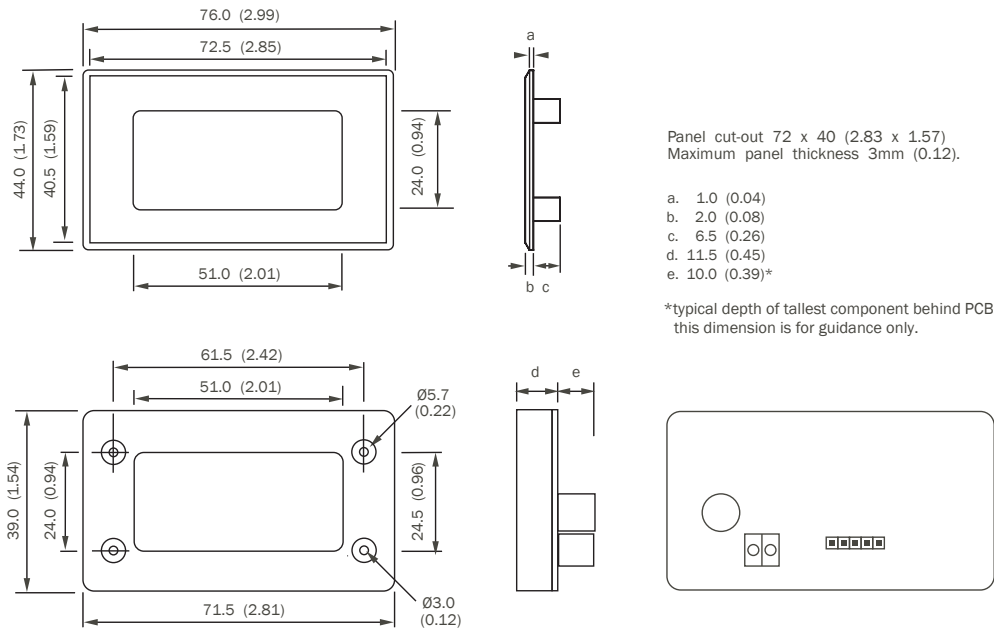

### SAFETY

To comply with the Low Voltage Directive (LVD 93/68/EEC), input voltages to the module's pins must not exceed 60v d.c. The user must ensure that the incorporation of the DPM into the user's equipment conforms to the relevant sections of BS EN 61010 (Safety Requirements for Electrical Equipment for Measuring, Control and Laboratory Use).

### OPERATING MODE

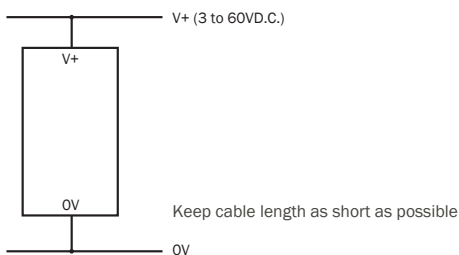

Measuring a supply voltage

NB: If you experience an error in the reading this may be due to voltage being dropped in the connecting leads. To minimise this effect use a thicker cable to reduce resistance.

Module House  
Whiteparish, Salisbury  
Wiltshire SP5 2SJ  
UK  
T +44 (1794) 884567  
F +44 (1794) 884616  
E sales@lascar.co.uk

4258 West 12th Street  
Erie  
PA 16505  
USA  
T +1 (814) 835 0621  
F +1 (814) 838 8141  
E us-sales@lascarelectronics.com

8th Floor, China Aerospace Centre  
143 Hoi Bun Road  
Kwun Tong, Kowloon  
HONG KONG  
T +852 2389 6502  
F +852 2389 6535  
E saleshk@lascar.com.hk

www.lascarelectronics.com

