



FLAME WATCH

FLAME DETECTOR & VIDEO CAMERA

Models:

FW-IR3S-A, FW-IR3S-R,
FW-IR3S-D, FW-IR3S-AD,
FW-UV/IRS-A, FW-UV/IRS-AR,
FW-UVS-A & FW-UVS-AR

FW-IR3S-X Shown



ISO 9001:2000



Part Number: MAN-0079 Rev 01
December 2008

IMPORTANT INFORMATION

This manual is for informational purposes only. Although every effort has been made to ensure the correctness of the information, technical inaccuracies may occur and periodic changes may be made without notice. Net Safety Monitoring Inc., assumes no responsibility for any error contained within this manual.

This manual is guide for use of the Flame Watch unit (IR3S, UV/IRS or UVS model Flame Detector with the VID-C or VID-C-50 Video Camera) and the data and procedures contained within this document have been verified and are believed to be adequate for the intended use of the device. If the device or procedures are used for purposes other than as described in the manual without receiving prior confirmation of validity or suitability, Net Safety Monitoring Inc. does not guarantee the results and assumes no obligation or liability.

No part of this manual may be copied, disseminated or distributed without the express consent of Net Safety Monitoring Inc.

Net Safety Monitoring Inc. products are carefully designed and manufactured from high quality components and can be expected to provide many years of trouble free service. Each product is thoroughly tested, inspected and calibrated prior to shipment. Failures can occur which are beyond the control of the manufacturer. Failures can be minimized by adhering to the operating and maintenance instructions herein. Where the absolute greatest of reliability is required, redundancy should be designed into the system.

WARRANTY

Net Safety Monitoring Inc warrants this device against defective parts and workmanship for a period of for 36 months from date of purchase. No other warranties or liability, expressed or implied, will be honoured by Net Safety Monitoring Inc.

Contact Net Safety Monitoring Inc. or an authorized representative for details.

We welcome your input at Net Safety Monitoring Inc. If you have any comments please contact us at the telephone number or address below or visit our web-site, www.net-safety.com, and complete our on-line customer survey.

CONTACT INFORMATION

Net Safety Monitoring Inc
Corporate Headquarters
2721 Hopewell Place NE

Direct: (403) 219-0688
Facsimile: (403) 219-0694
E-mail: nsmsales@net-safety.com

TABLE OF CONTENTS

| | |
|--|----|
| IMPORTANT INFORMATION | 2 |
| WARRANTY | 2 |
| CONTACT INFORMATION | 2 |
| SECTION 1: INTRODUCTION | 4 |
| Description | 4 |
| 1.1 Flame Watch Dimensional Drawing | 5 |
| 1.2 Mounting Flame Watch Unit | 6 |
| 1.3 Unpacking | 7 |
| 1.4 Field Installation..... | 7 |
| 1.4.1 Wiring | 7 |
| 1.4.2 Grounding | 7 |
| 1.4.3 Sealing | 7 |
| SECTION 2: CONNECTING FLAME WATCH | 8 |
| 2.1 IR3S Flame Watch Junction Box Terminal Board | 8 |
| 2.2 UVS or UV/IRS Flame Watch Junction Box Terminal Board..... | 9 |
| 2.3 DIP Switch (SW1) Positions..... | 10 |
| 2.4 Troubleshooting | 11 |
| 2.5 Maintenance | 11 |
| 2.6 How to Return Equipment | 12 |

| | |
|--|----|
| APPENDIX | 13 |
| Appendix A: ELECTROSTATIC SENSITIVE DEVICE (ESD) | 13 |
| Appendix B: RESISTANCE TABLE (OHMS) | 14 |
| Appendix C: TECHNICAL SPECIFICATION OF VIDEO CAMERA | 15 |
| Appendix D: IR3S SPECIFICATION | 16 |
| Appendix E: UV/IRS SPECIFICATION | 17 |
| Appendix F: UVS SPECIFICATION | 18 |

SECTION 1: INTRODUCTION

Description

Net Safety's Flame Watch has two component products; a Flame Detector and Video Camera mounted as a unit. With this combination and configuration the user is allowed to monitor a possible fire as well as intrusion in a specific coverage area. Furthermore, the user is provided with options in selecting the model Flame Detector to be used with the Video Camera.

The FW-IR3S is the valuable integration of a multi-spectral (3IR) Infrared Flame Detector and a Video Camera which is mounted in an explosion proof housing. The FW-UV/IRS and FW-UVS models are combinations of the Video Camera with the UV/IRS Flame Detector or the UVS Flame Detector.

The (IR3S) Phoenix, Net Safety's latest flame detection product, is a triple spectrum IR detector designed to respond to infrared radiation emitted by a wide range of hydrocarbon based fires. Refer to the (IR3S) Phoenix's manual (MAN-0044) for detailed operation.

The UV/IRS Flame Detector incorporates UV and IR detection circuitry to detect specific wavelengths in the UV and IR spectrum whenever a fire is present. This detector is designed to detect a wide range of hydrocarbon based fires. Refer to MAN-0015 for detailed operation. The UVS Flame Detector is also a member of Net Safety's line of fire detection products and is designed to detect a wide range of hydrocarbon, hydrogen and metal based fires. See MAN-0039 for more details.

The type of Flame Detector used, which determines the model Flame Watch, is dependent on the user's choice, environment and application.

The VID-C or VID-C-50 explosion proof Video Camera is ideally suited for safety monitoring systems in hazardous locations. The colour video camera is mounted in an explosion proof housing and delivers a composite video output for use with most VCR's or video monitors. The wide viewing angle provides for large area of coverage by one camera. Refer to the Video Camera's manual (MAN-0036) for detailed operation.

The Flame-Watch's two components are available with standard explosion proof (XP) housing. As a result, the Flame-Watch provides integrated security and performance required for high risk industrial installations.

1.1 Flame Watch Dimensional Drawing

Figure 1: Dimensional Drawing (Measurements are in Millimeters and Inches)

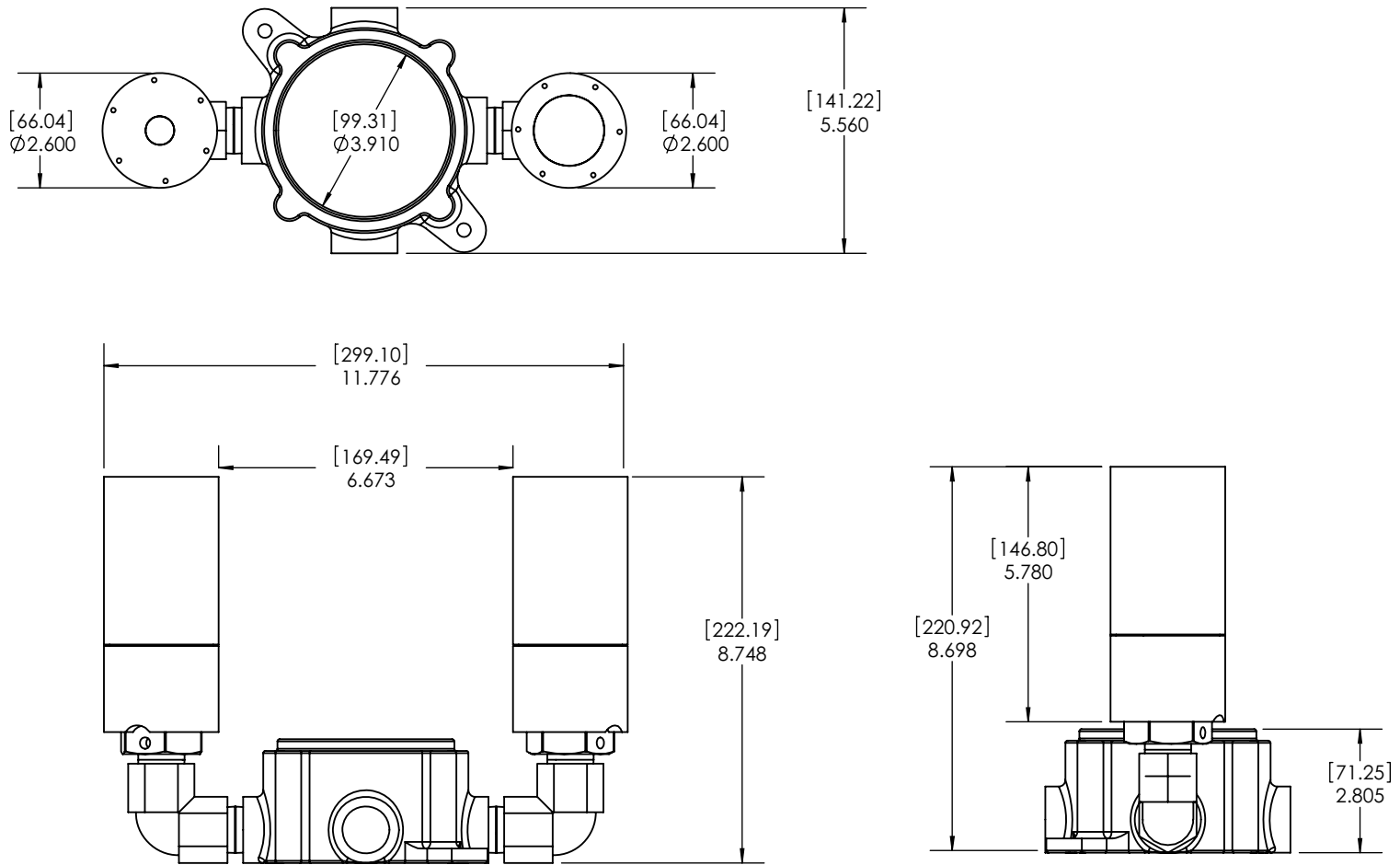

1.2 Mounting Flame Watch Unit

The Flame-Watch unit must be mounted and orientated exactly as shown below and be easily accessible for maintenance and calibration purposes. Ensure the Flame-Watch unit is securely mounted, taking into consideration all requirements.

Figure 2: Mounting

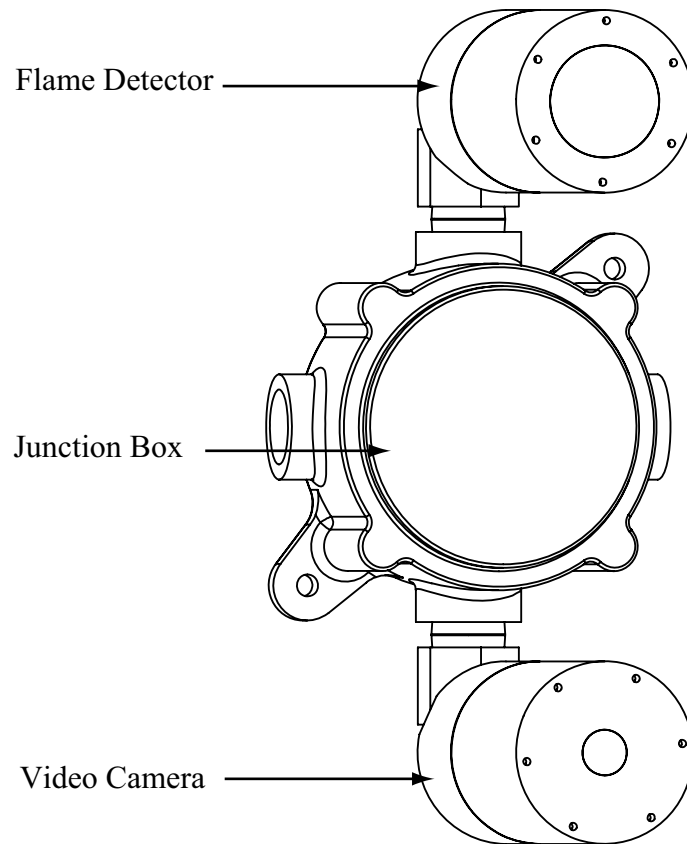

1.3 Unpacking

Remove all packaging components from the box. Carefully remove the Flame-Watch unit from its box and hold by the Junction box to prevent damage. Use Net Safety's lens cleaner to clean the lens of the Flame Detector and Video Camera before installation and operation.

WARNING:  The alignment of the Video Camera and Flame Detector has been factory set, care must be taken when handling the Flame-Watch system. Do not hold or apply excessive force to the mounted video camera and flame detector.

1.4 Field Installation

WARNING:  Compliance with regulations is the responsibility of the installer. Wiring must comply with applicable regulations relating to the installation of electrical equipment in a hazardous area.

1.4.1 Wiring

The use of shielded cable running through conduit is highly recommended for power input and signal wires to protect against interference caused by extraneous electrical 'noise'. When cable is installed in conduit, the conduit must not be used for wiring to other electrical equipment.

1.4.2 Grounding

Proper shielding and grounding procedures, for the specific area of installation, should always be followed.

1.4.3 Sealing

Water-proof and explosion-proof conduit seals are recommended to prevent the accumulation of moisture within the junction box. Seals should be located as close to the device as possible and not more than 18 inches (46 cm) away. Explosion-proof installations may require an additional seal where conduit enters a non-hazardous area. When pouring a seal, use a fibre dam to ensure proper formation of the seal. Seals should never be poured at temperatures below freezing. The jacket and shielding of the cable should be stripped back to permit the seal to form around the individual wires. This will prevent air, gas and water leakage through the inside of the shield and into the enclosure. It is recommended that explosion-proof drains and conduit breathers be used. Changes in temperature and barometric pressure can cause 'breathing' which allows moist air to enter the conduit.

SECTION 2: CONNECTING FLAME WATCH

2.1 IR3S Flame Watch Junction Box Terminal Board

The type Flame Detector and hence model Flame Watch chosen will depend on the particular application, environment and response needed. The IR3S model Flame Detectors available are analog, digital, analog/digital and relay. If the IR3S Flame Watch is being used, refer to Figure 3 and 4. The Flame Detector and Video Camera wires(except for the RCA cable) are factory fitted to the terminal board. User interface is made to terminal blocks J4 and J5. The male RCA video output cable from the camera should be connected to the user's video monitoring system. For operational details on each product, see specific manual.

Figure 3: Junction Box terminals for IR3S Flame detector

| FW-IR3S-A (analog unit)wiring | |
|-------------------------------|----------------------|
| Terminal J4 | Designation/Function |
| 1 | +Vin (Power +) |
| 2 | GND (Power -) |
| 3 | SIG(4-20 mA signal) |
| 4 | Not used |
| 5 | Not used |
| 6 | Earth |

| FW-IR3S-AD (analog/digital unit)wiring | |
|--|----------------------|
| Terminal J4 | Designation/Function |
| 1 | +Vin (Power +) |
| 2 | GND (Power -) |
| 3 | SIG (4-20mA signal) |
| 4 | Not used |
| 5 | Not used |
| 6 | Earth |

| Terminal J5 | Designation/Function |
|-------------|------------------------------|
| 1 | A(Blue digital signal wire) |
| 2 | B(Brown digital signal wire) |
| 3 | Not used |
| 4 | Not used |
| 5 | Not used |
| 6 | Not used |

Note: For IR3S-A and IR3S-AD, if isolated power configuration is being used, move jumper on IR3S unit to EXT position and connect purple wire (+ ISO wire) to external power supply. See IR3S manual.

| FW-IR3S-D (digital unit)wiring | |
|--------------------------------|----------------------|
| Terminal J4 | Designation/Function |
| 1 | +Vin (Power +) |
| 2 | GND (Power -) |
| 3 | Not used |
| 4 | Not used |
| 5 | Not used |
| 6 | Earth |

| Terminal J5 | Designation/Function |
|-------------|------------------------------|
| 1 | A(Blue digital signal wire) |
| 2 | B(Brown digital signal wire) |
| 3 | Not used |
| 4 | Not used |
| 5 | Not used |
| 6 | Not used |

| FW-IR3S-R (relay unit)wiring | |
|------------------------------|----------------------|
| Terminal J4 | Designation/Function |
| 1 | +Vin (Power +) |
| 2 | GND (Power -) |
| 3 | Not used |
| 4 | Not used |
| 5 | Not used |
| 6 | Earth |

| Terminal J5 | Designation/Function |
|-------------|-----------------------------------|
| 1 | (NO)Normally Open relay contact |
| 2 | COM (relay common) |
| 3 | (NC)Normally Closed relay contact |
| 4 | (NO)Normally Open relay contact |
| 5 | COM (relay common) |
| 6 | (NC)Normally Closed relay contact |

Figure 4: Flame Watch Terminal Board.

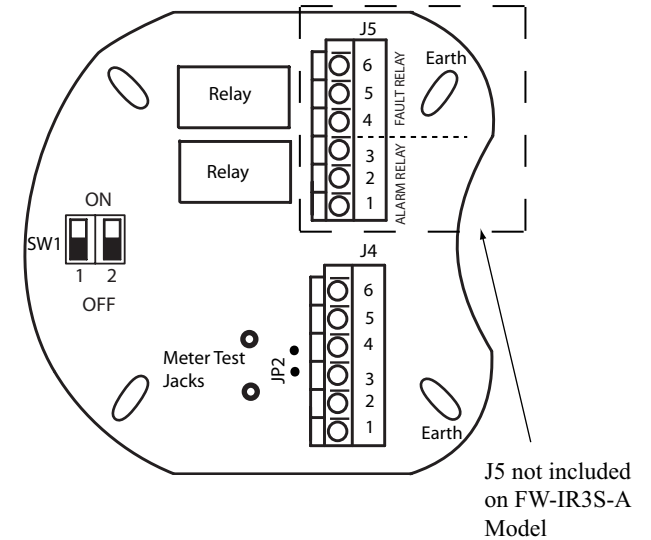

Note: The figure above is a general representation of the Flame Watch terminal board. If only relays are being used, place jumper over pins marked JP2.

2.2 UVS or UV/IRS Flame Watch Junction Box Terminal Board

The UVS or UV/IRS Flame Detector can be used instead of the IR3S Flame Detector as a part of the Flame Watch configuration. The UVS or UV/IRS model Flame Detector is available as a analog unit or analog with relays. If the UVS or UV/IRS Flame Detector is being used, refer to Figure 5 and 6 below. The detector and camera wires(except for the RCA cable) are factory fitted to the terminal board. The terminal blocks (J4 and J5) are designated for user interface(power, output, etc). The male RCA video output cable from the camera should be connected to the user’s video monitoring system. For operational details on each product, see specific manual.

Figure 5: Junction Box terminals for UVS or UV/IRS Flame detector

| FW-UVS-A or FW-UV/IRS-A(analog unit)wiring | |
|--|----------------------|
| Terminal J4 | Designation/Function |
| 1 | +Vin (Power +) |
| 2 | GND (Power -) |
| 3 | SIG(4-20 mA signal) |
| 4 | MVI (Manual VI) |
| 5 | Not used |
| 6 | Earth |

| FW-UVS-AR or FW-UV/IRS-AR(analog/ralay unit)wiring | |
|--|-----------------------------------|
| Terminal J4 | Designation/Function |
| 1 | +Vin (Power +) |
| 2 | GND (Power -) |
| 3 | SIG(4-20 mA signal) |
| 4 | MVI (Manual VI) |
| 5 | Not used |
| 6 | Earth |
| Terminal J5 | Designation/Function |
| 1 | (NO)Normally Open relay contact |
| 2 | COM (relay common) |
| 3 | (NC)Normally Closed relay contact |
| 4 | (NO)Normally Open relay contact |
| 5 | COM (relay common) |
| 6 | (NC)Normally Closed relay contact |

Figure 6: Flame Watch Terminal Board

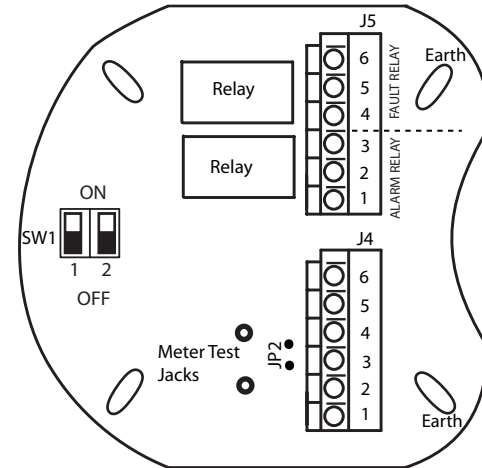

Note: The figure above is a general representation of the Flame Watch terminal board. If only relays are being used, place jumper over pins marked JP2

2.3 DIP Switch(SW1) Positions

The UVS-AR and UV/IRS-AR Flame Watch Terminal Board has a two position DIP Switch to define the Coil and Latch Status for the Fire Relay. Refer to Figure 7 for DIP Switch positions.

The default setting for the Fire Relay is Normally De-energized/Non-latching. The Fault Relay is factory set to Normally Energized/Non-latching and cannot be modified.

Figure 7: SW1 DIP Switch positions

| Coil and Latch Status | | |
|------------------------------|-------------------|-------------------|
| Fire Relay | Position 1 | Position 2 |
| De-energized / Non-latching | ON | ON |
| Energized / Non-latching | ON | OFF |
| De-energized / Latching | OFF | ON |
| Energized / Latching | OFF | OFF |

The IR3S Flame Watch Terminal Board doesn't have selectable DIP switches on the junction box terminal board. Relay conditions and coil status are determined by the DIP Swithes and jumper on the electronic IR3S Flame Detector module, see the IR3S manual (MAN-0044).

2.4 Troubleshooting

The Flame Watch is not designed to be repaired in the field. If a problem should develop, carefully check for correct wiring and refer to individual product manuals. If it is determined that the problem is caused by an electronic defect, the device should be returned to the factory for repair. See 'How to Return Equipment'.

2.5 Maintenance

To ensure reliable viewing and detecting, it is important to periodically clean the camera and flame detector window. Although the frequency of this cleaning is determined by the requirements of the particular process, it is recommended that the Flame Watch (flame detector and camera) be cleaned every year. See individual product manuals on maintenance.

2.6 How to Return Equipment

A Material Return Authorization number is required in order to return this equipment. Please contact Net Safety Monitoring at **(403) 219-0688** before returning equipment or consult our Service Department to possibly avoid returning equipment.

If you are required to return equipment, include the following information:

- 1 A Material Return Authorization number (provided over the phone to you by Net Safety).
- 2 A detailed description of the problem. The more specific you are regarding the problem, the more quickly our Service department can determine and correct the problem.
- 3 A company name, contact name and telephone number.
- 4 A Purchase Order, from your company, authorizing repairs or request for quote.
- 5 Ship all equipment, prepaid to:

Net Safety Monitoring Inc
2721 Hopewell Place NE
Calgary, Alberta, Canada
T1Y 7J7

6. Mark all packages: **RETURN for REPAIR**
7. Waybills, for shipments from outside Canada, must state:

Equipment being returned for repair
All charges to be billed to the sender

Please also ensure a duplicate copy of the packing slip is enclosed inside the box indicating item 1-4 along with the courier and account number for returning the goods.

All Equipment must be Shipped prepaid. Collect shipments will not be accepted.

Pack items to protect them from damage and use anti-static bags or aluminum-backed cardboard as protection from electrostatic discharge.

APPENDIX

Appendix A: ELECTROSTATIC SENSITIVE DEVICE - ESD

Electrostatic discharge (ESD) is the transfer, between bodies, of an electrostatic charge caused by direct contact or induced by an electrostatic field.

The most common cause of ESD is physical contact. Touching an object can cause a discharge of electrostatic energy—ESD! If the charge is sufficient and occurs near electronic components, it can damage or destroy those components.

In some cases, damage is instantaneous and an immediate malfunction occurs. However, symptoms are not always immediate—performance may be marginal or seemingly normal for an indefinite period of time, followed by a sudden failure.

To eliminate potential ESD damage, review the following guidelines:

- Handle boards by metal shields—taking care not to touch electronic components
- Wear grounded wrist or foot straps, or ESD shoes or heel grounders to dissipate unwanted static energy
- Prior to handling boards, dispel any charge in your body or equipment
- Ensure components are transported and stored in static safe packaging
- When returning boards, carefully package in the original carton and static protective wrapping
- Ensure ALL personnel are educated and trained in ESD Control Procedures

In general, exercise accepted and proven precautions normally observed when handling electrostatic sensitive devices.

A warning label is placed on the packaging, identifying product using electrostatic sensitive semiconductor devices.



Appendix B: RESISTANCE TABLE (OHMS)

Note: Resistance shown is one way. This figure should be doubled when determining closed loop resistance.



| Distance (Feet) | AWG #20 | AWG #18 | AWG #16 | AWG #14 | AWG #12 | AWG #10 | AWG #8 |
|-----------------|---------|---------|---------|---------|---------|---------|--------|
| 100 | 1.02 | 0.64 | 0.40 | 0.25 | 0.16 | 0.10 | 0.06 |
| 200 | 2.03 | 1.28 | 0.80 | 0.51 | 0.32 | 0.20 | 0.13 |
| 300 | 3.05 | 1.92 | 1.20 | 0.76 | 0.48 | 0.30 | 0.19 |
| 400 | 4.06 | 2.55 | 1.61 | 1.01 | 0.64 | 0.40 | 0.25 |
| 500 | 5.08 | 3.20 | 2.01 | 1.26 | 0.79 | 0.50 | 0.31 |
| 600 | 6.09 | 3.83 | 2.41 | 1.52 | 0.95 | 0.60 | 0.38 |
| 700 | 7.11 | 4.47 | 2.81 | 1.77 | 1.11 | 0.70 | 0.44 |
| 800 | 8.12 | 5.11 | 3.21 | 2.02 | 1.27 | 0.80 | 0.50 |
| 900 | 9.14 | 5.75 | 3.61 | 2.27 | 1.43 | 0.90 | 0.57 |
| 1000 | 10.20 | 6.39 | 4.02 | 2.53 | 1.59 | 1.09 | 0.63 |
| 1250 | 12.70 | 7.99 | 5.03 | 3.16 | 1.99 | 1.25 | 0.79 |
| 1500 | 15.20 | 9.58 | 6.02 | 3.79 | 2.38 | 1.50 | 0.94 |
| 1750 | 17.80 | 11.20 | 7.03 | 4.42 | 2.78 | 1.75 | 1.10 |
| 2000 | 20.30 | 12.80 | 8.03 | 5.05 | 3.18 | 2.00 | 1.26 |
| 2250 | 22.80 | 14.40 | 9.03 | 5.68 | 3.57 | 2.25 | 1.41 |
| 2500 | 25.40 | 16.00 | 10.00 | 6.31 | 3.97 | 2.50 | 1.57 |
| 3000 | 30.50 | 19.20 | 12.00 | 7.58 | 4.76 | 3.00 | 1.88 |
| 3500 | 35.50 | 22.40 | 14.10 | 8.84 | 5.56 | 3.50 | 2.21 |
| 4000 | 40.60 | 25.50 | 16.10 | 10.00 | 6.35 | 4.00 | 2.51 |
| 4500 | 45.70 | 28.70 | 18.10 | 11.40 | 7.15 | 4.50 | 2.82 |
| 5000 | 50.10 | 32.00 | 20.10 | 12.60 | 7.94 | 5.00 | 3.14 |
| 5500 | 55.80 | 35.10 | 22.10 | 13.91 | 8.73 | 5.50 | 3.46 |
| 6000 | 61.00 | 38.30 | 24.10 | 15.20 | 9.53 | 6.00 | 3.77 |

Appendix C: Technical Specifications of Video Camera.

(Refer to the VID-C/VID-C-50 manual(MAN-0036) for more detailed description of its operations and specifications)



| |
|--|
| Operating Voltage: 10.5 VDC to 32 VDC |
| Power Consumption (at 24 VDC): 2.0 Watts nominal. 70 mA nominal. |
| Operating Temperature: -25°C to +60°C (-13°F to +140°F). |
| Storage Temperature: -40°C to +60°C (-40°F to +140°F). |
| Resolution: Horizontal 420 TV lines. |
| Number of Pixels: Effective pixels: 512(H) 429(V) |
| Camera Enclosure Material: Powder coated or anodized aluminum (Optional Stainless Steel). |
| Certification: Housing is certified to CSA. Certified ratings are; NEMA 4X for environmental protection and CSA, Class I, Division 1 Groups B, C and D for hazardous locations. |
| Viewing Angle: VID-C (3.6 mm Lens): Horizontal 52° , VID-C-50 (25 mm Lens): Horizontal 9.14° with a scene of 8 feet by 10 feet located at a distance of 50 feet from the camera. |
| S/N (Signal to Noise ratio): > 48dB. |
| Output: 1Vp-p, 75 ohms composite signal (NTSC). |
| Connector: Standard RCA Video Signal Connector. |

Appendix D : IR3S SPECIFICATION

| Models | IR3S-A (Analog) | I3RS-R (Relay) | IR3S-AD (Analog/Digital) |
|------------------------------|---|--|--|
| Operating Voltage | 10 to 32 VDC measured at the detector | | |
| Power Consumption (@ 24Vdc) | Nominal 30mA/ 0.72W Maximum 64mA/ 1.44W | De-Energized: Nominal 39mA/0.96W. Maximum 73mA/ 1.68W Energized: Nominal- 51mA, =1.20w). Maximum- 86mA, 2.16W | Nominal 30mA/ 0.72W Maximum 64mA/ 1.44W |
| Power Consumption (@ 12Vdc) | Nominal 45mA/ 0.60W Maximum 113mA/ 1.32W | De-Energized: Nominal- 66mA/0.84W. Maximum- 138mA/ 1.68W Energized: Nominal- 93mA, =1.08w) Maximum- 165mA, 2.04W | Nominal 45mA/ 0.60W Maximum 113mA/ 1.32W |
| In Rush Current (at 24Vdc) | Up to 2.6 A for 2.ms (varies with power supply) | | |
| Output | 0 to 20 mA – Into a max loop impedance of 800Ohms @ 32Vdc or 150Ohms @ 11.0Vdc. Non-Isolated loop supply | Normally open/Normally closed contacts rated for 5A @ 30Vdc/125Vac. Selectable energized/ de-energized Fire relay. Fault relay fixed as energized and both Fire & Fault relays fixed as non-latching | 0 to 20 mA – Into a max loop impedance of 800Ohms @ 32Vdc or 150Ohms @ 11.0Vdc. Non-Isolated loop supply. RS-485 RTU Modbus protocol. |
| Field of View | FM Performance tested: 100° horizontal / 100° vertical @ 50% of the on-axis detection distance for N-Heptane. 70° horizontal / 70° vertical at a distance of 200ft(Not FM Performance tested) | | |
| Spectral Range | The IR3S fire detector measures at three distinct Infrared Wavelengths | | |
| Time Delay | DIP switch selectable 0, 3, 5, 10 seconds, | | |
| Sensitivity Settings | Two (2) adjustable setting via DIP switch (High/Low) | | |
| Temperature/ RH | FM Certified (-40°C to +75°C / -40°F to 167°F). Operational (-50°C to +75°C / -58°F to 167°F). 0 – 95% RH non condensing | | |
| Metallurgy & IP/Nema Ratings | Aluminum or SS316 (factory sealed housing). IP66 and NEMA 4X | | |
| Weight (with swivel) | 2.1Kg /4.5lbs (SS316 Option @ 3.4Kg/ 7.5lbs) | | |
| Approvals | <p>Performance certified to: Class3260, ANSI/NEMA 250, and IEC60529.</p>   <p>us Class I, Div 1, Grps BCD, T5. Ex d IIB+H2 T5. Class I, Zone 1, Grps IIB+H2, T5; Nema 4X, IP66. For CANADA ONLY, Class I, Div 1, Grps A (Canada ONLY – with special cementing), BCD, T5. Ex d IIB+H2 T5.</p> | | |



NOTE: Performance certified by FM with maximum sensitivity setting and zero second time delay.

APPENDIX E : UV/IRS SPECIFICATION

| Models | UV/IRS-A (Analog) | UV/IRS-AR (Analog/Relay) |
|----------------------|---|---|
| Operating Voltage | 10 to 32 VDC | |
| Power Consumption | At 10Vdc: Nominal 95mA/ 0.95W. Maximum 225mA/ 2.25W *With Heater: Nominal 200mA/ 2.0W. Maximum 345mA/ 3.45W | At 10Vdc: Nominal 95mA/ 0.95W. Maximum 225mA/ 2.25W *With Heater: Nominal 200mA/ 2.0W. Maximum 335mA/ 3.35W |
| | At 24Vdc: Nominal 45mA/ 1.1W. Maximum 115mA/ 2.76W *With Heater: Nominal 90mA/ 2.16W. Maximum 165mA/ 3.96W | At 24Vdc: Nominal 45mA/ 1.1W. Maximum 115mA/ 2.76W *With Heater: Nominal 90mA/ 2.16W. Maximum 165mA/ 3.96W |
| | At 32Vdc: Nominal 35mA/ 1.12W. Maximum 105mA/ 3.36W *With Heater: Nominal 70mA/ 2.24W. Maximum 145mA/ 4.64W | At 32Vdc: Nominal 35mA/ 1.12W. Maximum 105mA/ 3.36W *With Heater: Nominal 70mA/ 2.24W. Maximum 145mA/ 4.64W |
| In Rush Current | 1.5A for 22ms | |
| Current Output | 0 to 20 mA – Into a max loop impedance of 800Ohms @ 32Vdc or 150Ohms @ 11.0Vdc. Non-Isolated loop supply | |
| Relay Output | N/A | Form C contacts rated 1A @ 30Vdc, 0.5A @125Vac. Selectable energized/ de-energized, latching/ non-latching Fire relay. Fault relay fixed as energized/ non-latching |
| Field of View | 120° Horizontal, 95° Vertical @ 50% of maximum on axis distance. | |
| Spectral Range | UV radiation over the range of 185 to 260 nanometres (1850 to 2600 angstroms); IR radiation in the 4.4micron range | |
| Time Delay | DIP switch selectable 0, 3, 5, 7 seconds, | |
| Sensitivity Settings | DIP switch selectable 8, 16, 24 or 32 counts per seconds | |
| Temperature & RH | FM Certified (-40°C to +75°C / -40°F to 167°F). Operational (-50°C to +75°C / -58°F to 167°F). 0 – 95% RH non condensing | |
| Metallurgy & IP/NEMA | Aluminum or SS316 (factory sealed housing). IP66 and NEMA 4X | |
| Weight (with swivel) | 2.1Kg /4.5lbs (SS316 Option @ 3.4Kg/ 7.5lbs) | |
| Approvals | FM Performance certified to: Class3260, ANSI/NEMA 250, and IEC60529.   Class I, Div 1, Grps A,B,C,D, T5. Ex d IIB+H2 T5. Class I, Zone 1, Grps IIB+H2 T5; Nema 4X, IP66. | |

NOTE: Performance certified by FM with maximum sensitivity setting and zero second time delay

APPENDIX F: UVS SPECIFICATION

| Models | UVS-A (Analog) | UVS-AR (Analog/Relay) |
|----------------------|---|---|
| Operating Voltage | 10 to 32 VDC | |
| Power Consumption | At 10Vdc: Nominal 95mA/ 0.95W. Max 225mA/ 2.25W *With Heater: Nominal 200mA/ 2.0W. Maximum 335mA/ 3.35W | At 10Vdc: Nominal 95mA/ 0.95W. Max 225mA/ 2.25W *With Heater: Nominal 200mA/ 2.0W. Maximum 335mA/ 3.35W |
| | At 24Vdc: Nominal 45mA/ 1.1W. Max 115mA/ 2.76W *With Heater: Nominal 90mA/ 2.16W. Maximum 165mA/ 3.96W | At 24Vdc: Nominal 45mA/ 1.1W. Max 95mA/ 2.28W *With Heater: Nominal 90mA/ 2.16W. Maximum 145mA/ 3.48W |
| | At 32Vdc: Nominal 35mA / 1.12W. Max 105mA/ 3.36W *With Heater: Nominal 70mA/ 2.24W. Maximum 140mA/ 4.48W | At 32Vdc: Nominal 35mA/ 1.12W. Max 80mA/ 2.56W *With Heater: Nominal 70mA/ 2.24W. Maximum 115mA/ 3.68W |
| In Rush Current | 1.5A for 22ms | |
| Current Output | 0 to 20 mA – Into a max loop impedance of 800Ohms @ 32Vdc or 150Ohms @ 11.0Vdc. Non-Isolated loop supply | |
| Relay Output | N/A | Form C contacts rated 1A @ 30Vdc, 0.5A @125Vac. Selectable energized/ de-energized, latching/ non-latching Fire relay. Fault relay fixed as energized/ non-latching |
| Field of View | 120° Horizontal, 95° Vertical @ 50% of maximum on axis distance. | |
| Spectral Range | UV radiation over the range of 185 to 260 nanometres (1850 to 2600 angstroms) | |
| Time Delay | DIP switches selectable 0, 3, 5, 7 seconds. | |
| Sensitivity Settings | DIP switch selectable 8, 16, 24 or 32 counts per seconds | |
| Temperature & RH | FM Certified (-40°C to +75°C / -40°F to 167°F). Operational (-50°C to +75°C / -58°F to 167°F). 0 – 95% RH non condensing | |
| Metallurgy & IP/NEMA | Aluminum or SS316 (factory sealed housing). IP66 and NEMA 4X | |
| Weight (with swivel) | 2.1Kg /4.5lbs (SS316 Option @ 3.4Kg/ 7.5lbs) | |
| Approvals | FM Performance certified to: Class3260, ANSI/NEMA 250, IEC60529.   Class I, Div 1, Grps A,B,C,D, T5. Ex d IIB+H2 T5. Class I, Zone 1, Grps IIB+H2 T5; Nema 4X, IP66. | |

NOTE: Performance certified by FM with maximum sensitivity setting and zero second time delay

Net Safety Monitoring Inc.

2721 Hopewell Place NE, Calgary, AB Canada T1Y 7J7

1-866-FIREGAS (347-3427) | ph. (403) 219-0688 | fx. (403) 219-0694

<http://www.net-safety.com> | Email: nsmsales@net-safety.com

PRODUCT SERVICES CONTACT INFORMATION

Telephone [8am - 5pm MDT]: (403) 769-6074 | (403) 717-8219

Fax: (403) 219-0694 Email: productservices@net-safety.com

http://www.net-safety.com/service/product_services.html

