

Operating Manual



16 Series Precision Gas Mass Flow Controller

Notice: Alicat Scientific, Inc. reserves the right to make any changes and improvements to the products described in this manual at any time and without notice. This manual is copyrighted. This document may not, in whole or in part, be copied, reproduced, translated, or converted to any electronic medium or machine readable form, for commercial purposes, without prior written consent from the copyright holder.

Note: Although we provide assistance on Alicat Scientific products both personally and through our literature, it is the complete responsibility of the user to determine the suitability of any product to their application.

Alicat Scientific, Inc.'s Wide-Range Laminar Flow Element Patent: The wide-range laminar flow element and products using the wide-range laminar flow element are covered by U.S. Patent Number: 5,511,416. Manufacture or use of the wide-range laminar flow element in products other than Alicat Scientific products or other products licensed under said patent will be deemed an infringement.

Limited Lifetime Warranty

Alicat Scientific, Inc. warrants to the original purchaser (hereinafter referred to as "Buyer") that instruments manufactured by Alicat Scientific (hereinafter referred to as "Product") shall be free from defects in materials and workmanship for the life of the Products.

Under this warranty, the Product will be repaired or replaced at manufacturer's option, without charge for parts or labor when the Product is carried or shipped prepaid to the factory together with proof of purchase.

The foregoing shall constitute the exclusive and sole remedy in lieu of other remedies of the Buyer for any breach by Alicat Scientific of this warranty to the maximum extent permitted by law.

This warranty does not apply to any Product which has not been installed or used in accordance with the Product operation and installation specifications provided to Buyer verbally or in writing by Alicat Scientific for the proper and normal use of the Product.

Buyer agrees hereunder that Alicat reserves the right to void any warranty, written or implied, if upon Alicat's examination of Product shall disclose to Alicat's satisfaction that the Product failure was due solely, or in part, to accident, misuse, neglect, abuse, alteration, improper installation, unauthorized repair or improper testing by Buyer or agent of Buyer.

Alicat Scientific shall not be liable under any circumstances for indirect, special, consequential, or incidental damages in connection with, or arising out of, the sale, performance, or use of the Products covered by this warranty.

Alicat Scientific does not recommend, warrant or assume responsibility for the use of the Products in life support applications or systems.

Alicat's warranties as herein above set forth shall not be enlarged, diminished or affected by, and no obligation or liability shall arise or grow out of Alicat's rendering of technical advice in connection with Buyer's order of the Products furnished hereunder.

If Product becomes obsolete, Alicat Scientific, at its own discretion, reserves the right to repair the Product with available replacement parts or upgrade the Product to a current, commercially available version of the original Product. Should upgrading the Product be deemed necessary by Alicat, Buyer hereby agrees to pay an upgrade fee equal to seventy percent of the retail value of the replacement Product. Alicat Scientific hereunder makes no claim that replacement Products will look, function or operate in the same or similar manner as the original product.

When a Product is returned to Alicat Scientific for recalibration this service is considered normal preventative maintenance. Recalibration of Product shall not be treated as a warranty service unless recalibration of Product is required as the result of repairs to Product pursuant to this Warranty. **Failure to recalibrate Product on a yearly basis will remove any and all obligations regarding repair or replacement of Product as outlined by this Warranty to Buyer from Alicat Scientific.**

This Warranty is in lieu of all other relevant warranties, expressed or implied, including the implied warranty of merchantability and the implied warranty of fitness for a particular purpose, and any warranty against infringement of any patent.

Continued use or possession of Products after expiration of the applicable warranty period stated above shall be conclusive evidence that the warranty is fulfilled to the full satisfaction of Buyer.

Alicat makes no warranty as to experimental, non-standard or developmental Products.

Accessories purchased from Alicat are not covered by this warranty.

Conformity / Supplemental Information:

The product complies with the requirements of the Low Voltage Directive 73/23/EEC and the EMC Directive 89/336/EEC (including 93/68/EEC) and carries the CE Marking accordingly. Contact the manufacturer for more information.

Table of Contents	Page
Installation	5
Plumbing	5
Mounting	5
Application	5
Power and Signal Connections	6
Input Signals	7
Analog Input Signal	7
RS-232 Input Signal	7
Output Signals	7
RS-232 Digital Output Signal	8
Standard Voltage (0-5 Vdc) Output Signal	8
Optional 0-10 Vdc Output Signal	8
Optional Current (4-20 mA) Output Signal	8
Optional 2nd Analog Output Signal	8
MC Series Mass Flow Controller Operation	10
Main Mode	10
Set-Pt.	10
Gas Absolute Pressure	10
Gas Temperature	11
Volumetric Flow Rate	11
Mass Flow Rate	11
<i>Flashing Error Message</i>	11
Select Menu Mode	11
Control Setup Mode	12
Input	12
Loop	13
Select	13
Gas Select Mode	14
Communication Select Mode	15
Unit ID	15
Baud	15
Data Rate	15
Manufacturer Data Mode	16
Miscellaneous Mode	16
LCD Contrast	17
Display Zero Deadband	17
Pressure Averaging	17
Flow Averaging	17
MCV Controller Operating Notes	18
RS-232 Output and Input	19
Configuring HyperTerminal®	19
Changing from Streaming to Polling Mode	19
Sending a Set-Point via RS-232	20
To adjust the P & D terms via RS-232	20
Gas Select	21
Collecting Data	23
Data Format	23

Table of Contents	Page
Sending a Simple Script File to HyperTerminal®	24
Operating Principle	25
Gas Viscosity	25
Other Gases	26
Volume Flow vs. Mass Flow	26
Volumetric Flow and Mass Flow Conversion	27
Compressibility	27
Standard Gas Data Tables	28
Gas Viscosities, Densities and Compressibilities at 25° C	29
Gas Viscosities, Densities and Compressibilities at 0° C	30
Troubleshooting	31
Maintenance and Recalibration	32
MC Series Technical Specifications	33
MC Series Dimensional Drawings	37
MCV Technical Specifications	40
PROFIBUS Technical Specifications	41
Additional Information	
Option: Totalizing Mode	43
Option: Portable Meters and Gauges	44
Option: Remote Electronics	45
Accessory: BB-9 Multi-Drop Box	45
Accessory: RS-232 to RS-485 Converter	45
Accessory: Flow Vision™ SC	46
Accessories	47
DB15 Pin-Out Diagrams	48

Table of Figures	
Figure 1. 8 Pin Mini-DIN Connector	6
Figure 2. Simple method for providing set-point to controllers	7
Figure 3. Mini-DIN to DB-9 Connection for RS-232 Signals	8
Figure 4. Typical Multiple Device (Addressable) Wiring Configuration	9
Figure 5. Optional Industrial Connector	9
Figure 6. Main Mode Display, MC Series Flow Controller	10
Figure 7. Select Menu Display	11
Figure 8. MC Series Control Setup Display	12
Figure 9. Gas Select Display	14
Figure 10. Communication Select Display	15
Figure 11. Manufacturer Data Displays	16
Figure 12. Miscellaneous Mode Display	17
Figure 13. MCV Controller with Three-Way Solenoid Valve	18

Thank you for purchasing an MC Series Gas Flow Controller. Please take the time to find and read the information contained in this manual. This will help to ensure that you get the best possible service from your instrument. This manual covers the following Alicat Scientific instruments:

MC Series 16 Bit Mass Gas Flow Controllers

MC-XXSCCM-D

MC-XXSLPM-D

MCR-XXXSLPM

MCV Series 16 Bit Mass Gas Flow Controllers

MCV-XXSLPM

Installation

Plumbing

All MC Series Gas Flow Controllers are equipped with female inlet and outlet port connections. Because the flow controllers set up a laminar flow condition within the flow body, no straight runs of pipe are required upstream or downstream of the controller. The inlet and outlet ports are equal in size and symmetric (in-line). The port sizes (process connections) and mechanical dimensions for different flow ranges are shown on pages 37-39.

Controllers with M5 (10-32) ports have o-ring face seals and require no further sealant or tape. On other controllers, avoid the use of pipe dopes or sealants on the ports as these compounds can cause permanent damage to the controller should they get into the flow stream. Use of thread sealing Teflon tape is recommended to prevent leakage around the threads. When applying the tape, avoid wrapping the first thread or two to minimize the possibility of getting a piece of shredded tape into the flow stream. When changing fittings, always clean any tape or debris from the port threads.

It is also recommended that a 20 micron filter be installed upstream of controllers with full scale ranges of 1(S)LPM or less and a 50 micron filter be installed upstream of controllers with full scale ranges above 1(S)LPM.

Mounting

All MC Series Gas Flow Controllers have mounting holes for convenient mounting to flat panels. The sizes and dimensions for the mounting holes are shown on pages 37-39. Position sensitivity is not generally an issue with small valve controllers. Large valve controllers are somewhat position sensitive because of the fairly massive stem assembly. It is generally recommended that they be mounted so that the valve cylinder is vertical and upright. The primary concern in mounting a large valve controller in a position other than the recommended position is the increased risk of leakage when the controller is given a zero set-point and is being held closed by the spring force.

Application

Maximum operating line pressure is 145 PSIG (1 MPa).

Caution: *Exceeding the maximum specified line pressure may cause permanent damage to the solid-state differential pressure transducer.*

If the line pressure is higher than 145 PSIG (1 MPa), a pressure regulator should be used upstream from the flow controller to reduce the pressure to 145 PSIG (1 MPa) or less if possible. Many of our controllers are built after extensive consultations with the customer regarding the specific application. The result is that two controllers with the same flow range and part number may look and act quite differently depending upon the application the controller was built for. Care should be taken in moving a controller from one application to another to test for suitability in the new application.

Power and Signal Connections

Power can be supplied to your MC Series controller through either the power jack or the 8 pin Mini-DIN connector as shown in Figure 1. Power may also be supplied through an AC to DC adapter which converts line AC power to DC voltage and current as specified below. The power jack accepts 2.1 mm female power plugs with positive centers. Cables and AC/DC adaptors may be purchased from the manufacturer (see Accessories page 47) and are commonly available at local electronics suppliers.

Small Valve: If your controller utilizes a small valve (about the size of your thumb), a 12-30Vdc power supply with a 2.1 mm female positive center plug capable of supplying 250 mA is recommended.

Note: 4-20mA output requires at least 15 Vdc.

Large Valve: If your controller utilizes a large valve (about the size of your fist), a 24-30 Vdc power supply with a 2.1 mm female positive center plug capable of supplying at least 750mA is required.

Alternatively, power can be supplied through the Mini-DIN connector as shown below:

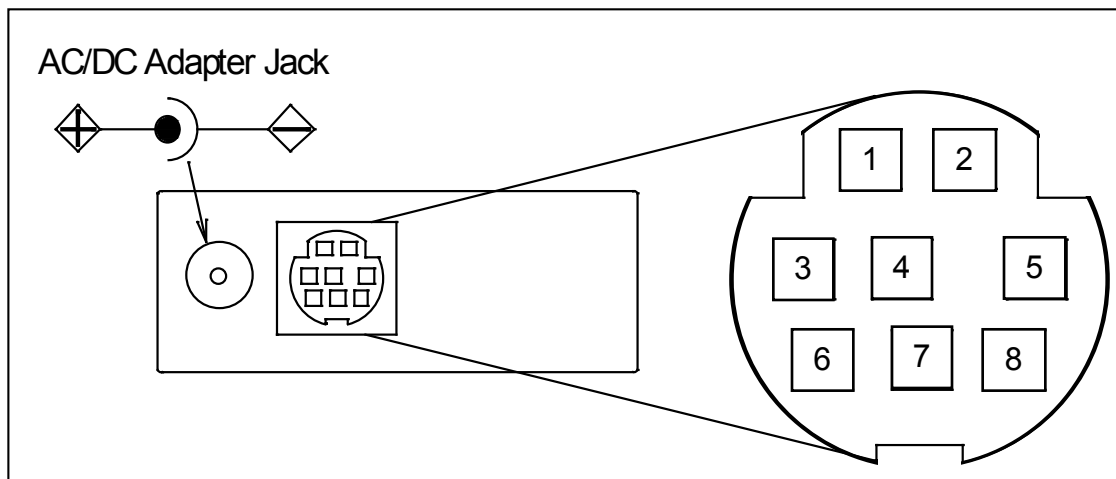

Pin	Function	Mini-DIN cable color
1	Inactive or <u>4-20mA Primary Output Signal</u>	Black
2	Static 5.12 Vdc or <u>Secondary Analog Output (4-20mA, 5Vdc, 10Vdc)</u> or <u>Basic Alarm</u>	Brown
3	RS-232 Input Signal	Red
4	Analog Input Signal	Orange
5	RS-232 Output Signal	Yellow
6	0-5 Vdc (or <u>0-10 Vdc</u>) Output Signal	Green
7	Power In (as described above)	Blue
8	Ground (common for power, communications and signals)	Purple

Note: The above pin-out is applicable to all the flow meters and controllers available with the Mini-DIN connector. The availability of different output signals depends on the options ordered.

Underlined Items in the above table are optional configurations that are noted on the unit's calibration sheet.

Figure 1. 8 Pin Mini-DIN Connector

CAUTION: Do not connect power to pins 1 through 6 as permanent damage can occur!

Note: Upon initial review of the pin out diagram in Figure 1, it is common to mistake Pin 2 (labeled 5.12 Vdc Output) as the standard 0-5 Vdc analog output signal! In fact Pin 2 is normally a constant 5.12 Vdc that reflects the system bus voltage and can be used as a source for the set-point signal.

Input Signals

Analog Input Signal

Apply analog input to Pin 4 as shown in Figure 1.

Standard 0-5 Vdc: Unless ordered otherwise, 0-5 Vdc is the standard analog input signal. Apply the 0-5 Vdc input signal to pin 4, with common ground on pin 8. The 5.12 Vdc output on pin 2 can be wired through a 50K ohm potentiometer and back to the analog input on pin 4 to create an adjustable 0-5 Vdc input signal source as shown below.

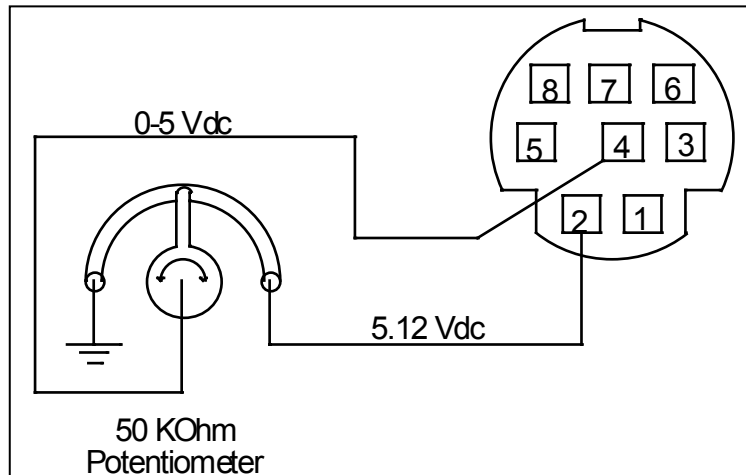

Figure 2. Simple method for providing set-point to controllers

Optional 0-10 Vdc: If specified at time of order, a 0-10 Vdc input signal can be applied to pin 4, with common ground on pin 8.

Optional 4-20 mA: If specified at time of order, a 4-20 mA input signal can be applied to pin 4, with common ground on pin 8. **Note:** 4-20mA output requires at least 15 Vdc power input.

RS-232 Digital Input Signal

If you will be using the RS-232 input signal, it is necessary to connect the RS-232 Output Signal (Pin 5), the RS-232 Input Signal (Pin 3), and Ground (Pin 8) to your computer serial port as shown in Figure 3. Adapter cables are available from the manufacturer or they can be constructed in the field with parts from an electronics supply house. In Figure 3, note that the diagrams represent the “port” side of the connections, i.e. the connector on top of the meter and the physical DB-9 serial port on the back of the computer. The cable ends will be mirror images of the diagram shown in Figure 3. (See page 19 for details on accessing RS-232 input.)

Output Signals

Note: Upon initial review of the pin out diagram in Figure 1 (page 6), **it is common to mistake Pin 2 (labeled 5.12 Vdc Output) as the standard 0-5 Vdc analog output signal!** In fact Pin 2 is normally a constant 5.12 Vdc that reflects the system bus voltage and can be used as a source for the input signal. This allows the user in the field to run this output through a 50K ohm potentiometer and back into the analog set-point pin to create a 0-5 Vdc set-point source.

RS-232 Digital Output Signal

If you will be using the RS-232 output signal, it is necessary to connect the RS-232 Output Signal (Pin 5), the RS-232 Input Signal (Pin 3), and Ground (Pin 8) to your computer serial port as shown in Figure 3. Adapter cables are available from the manufacturer or they can be constructed in the field with parts from an electronics supply house. In Figure 3, note that the diagrams represent the “port” side of

the connections, i.e. the connector on top of the meter and the physical DB-9 serial port on the back of the computer. The cable ends will be mirror images of the diagram shown in Figure 3. (See page 19 for details on accessing RS-232 output.)

Standard Voltage (0-5 Vdc) Output Signal

All MC Series flow controllers have a 0-5 Vdc (optional 0-10 Vdc) output signal available on Pin 6. This is generally available in addition to other optionally ordered outputs. This voltage is usually in the range of 0.010 Vdc for zero flow and 5.0 Vdc for full-scale flow. The output voltage is linear over the entire range. Ground for this signal is common on Pin 8.

Optional 0-10 Vdc Output Signal

If your controller was ordered with a 0-10 Vdc output signal, it will be available on Pin 6. (See the Calibration Data Sheet that shipped with your controller to determine which output signals were ordered.) This voltage is usually in the range of 0.010 Vdc for zero flow and 10.0 Vdc for full-scale flow. The output voltage is linear over the entire range. Ground for this signal is common on Pin 8.

Optional Current (4-20 mA) Output Signal

If your controller was ordered with a 4-20 mA current output signal, it will be available on Pin 1. (See the Calibration Data Sheet that shipped with your controller to determine which output signals were ordered.) The current signal is 4 mA at 0 flow and 20 mA at the controller's full scale flow. The output current is linear over the entire range. Ground for this signal is common on Pin 8. (Current output units require 15-30Vdc power.)

Note: *This is a current sourcing device. Do not attempt to connect it to "loop powered" systems.*

Optional 2nd Analog Output Signal

You may specify an optional 2nd analog output on Pin 2 at time of order. (See the Calibration Data Sheet that shipped with your controller to determine which output signals were ordered.) This output may be a 0-5 Vdc, 0-10 Vdc, or 4-20 mA analog signal that can represent any measured parameter. With this optional output, a volumetric flow controller could output the volumetric flow rate with a 0-5 Vdc signal (on pin 6) and a 4-20 mA signal (on pin 2), or a mass flow controller could output the mass flow rate (0-5 Vdc on pin 6) and the absolute pressure (0-5 Vdc on pin 2).

Note: *This is a current sourcing device. Do not attempt to connect it to "loop powered" systems.*

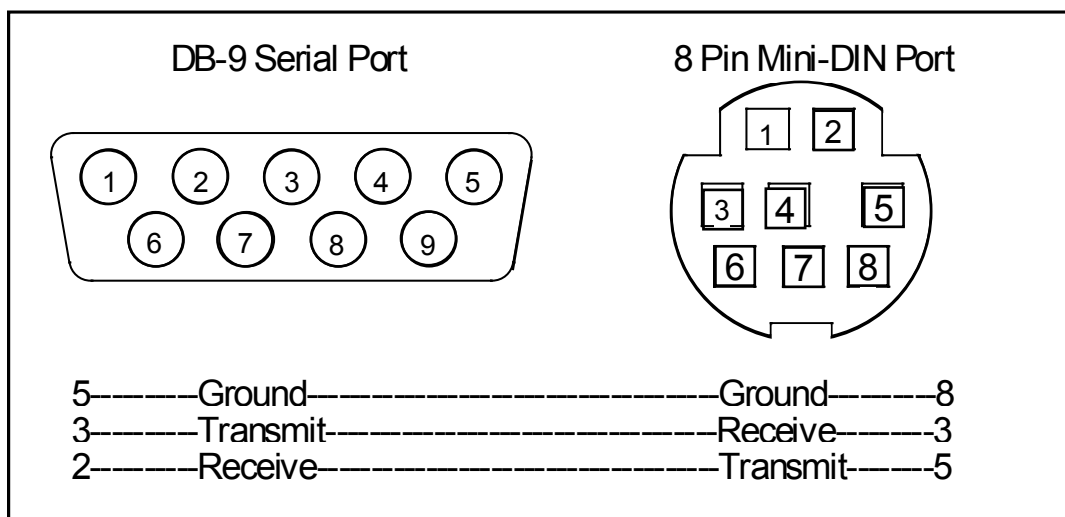

Figure 3. Mini-DIN to DB-9 Connection for RS-232 Signals

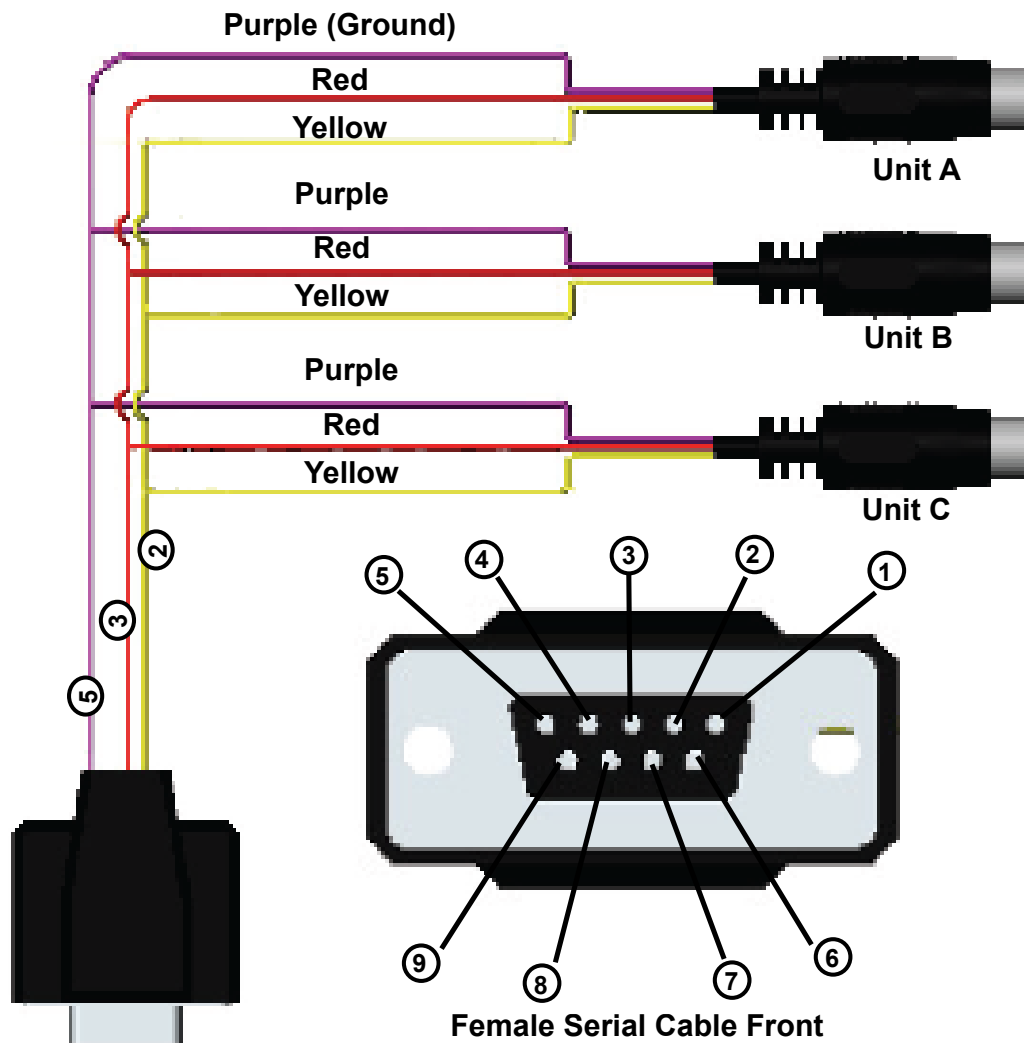

Figure 4. Typical Multiple Device (Addressable) Wiring Configuration

Note: The easiest way to connect multiple devices is with a Multi-Drop Box (see page 45).

An optional industrial connector is also available:

Pin	Function	Cable Color
1	Power In (+)	Red
2	RS-232 Output	Blue
3	RS-232 Input Signal	White
4	Analog Input Signal	Green
5	Ground (common for power, communications and signals)	Black
6	Signal Out (Voltage or Current as ordered)	Brown

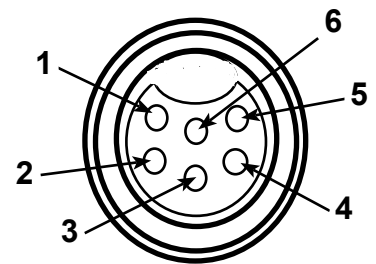

Figure 5. Optional Industrial Connector

Note: The above pin-out is applicable to all the flow meters and controllers ordered with the industrial connector. The availability of different output signals depends on the flow controller options ordered.

DB15 Pin-out Diagrams: Pin-out diagrams for devices ordered with a DB15 connector can be found on pages 48 and 49.

PROFIBUS Pin-out Diagrams: Pin-out diagrams for PROFIBUS configured devices can be found on page 41.

MC Series Mass Flow Controller Operation

The MC Series Mass Flow Controller provides a multitude of useful flow data in one simple, rugged device. The MC Series can have several screen “modes” depending on how the device is ordered. All MC Series controllers have a default Main Mode, Select Menu Mode, Control Set Up Mode, Gas Select Mode (the Gas Select Mode may not be available on controllers calibrated for a custom gas or blend), Communication Select Mode, Manufacturer Data Mode and a Miscellaneous Mode. In addition, your device may have been ordered with the optional Totalizing Mode (page 43). The device defaults to Main Mode as soon as power is applied to the controller.

Main Mode

The main mode screen defaults on power up with the mass flow on the primary display. The following parameters are displayed in the main mode as shown in Figure 6.

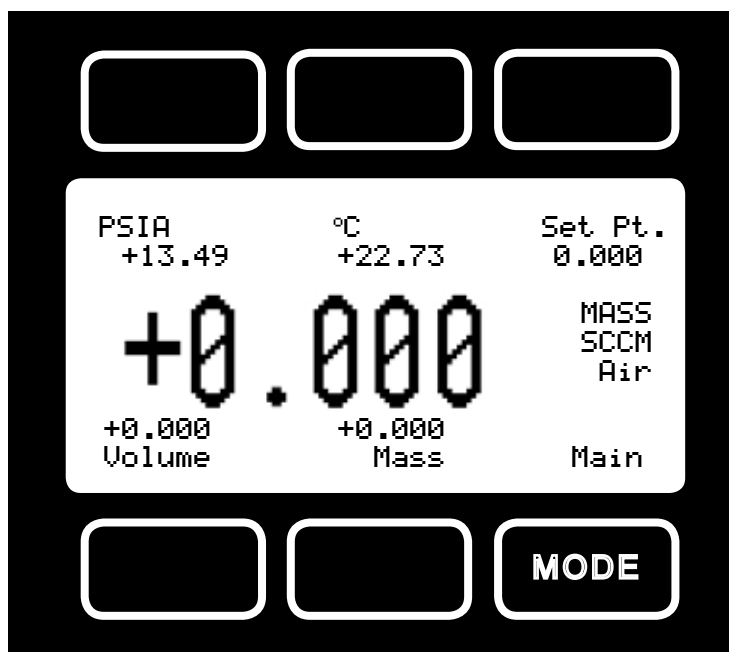

Figure 6. Main Mode Display, MC Series Flow Controller

The “MODE” button in the lower right hand corner toggles the display between modes.

Set Pt. – The set-point is shown in the upper right corner of the display. The set-point cannot be adjusted from the main mode screen. For information on changing the set-point, see “**Set**”, page 13.

Gas Absolute Pressure: The MC Series flow controllers utilize an absolute pressure sensor to measure the line pressure of the gas flow being monitored. This sensor references hard vacuum and accurately reads line pressure both above and below local atmospheric pressure. This parameter is located in the upper left corner of the display under the dynamic label “PSIA”. This parameter can be moved to the primary display by pushing the button just above the dynamic label (top left). The engineering unit associated with absolute pressure is pounds per square inch absolute (PSIA). This can be converted to gage pressure (PSIG = the reading obtained by a pressure gauge that reads zero at atmospheric pressure) by simply subtracting local atmospheric pressure from the absolute pressure reading:

$$\text{PSIG} = \text{PSIA} - (\text{Local Atmospheric Pressure})$$

The flow meters use the absolute pressure of the gas in the calculation of the mass flow rate. If working in metric units, note that 1 PSI = 6.89 kPa.

Gas Temperature: The MC Series flow controllers utilize a temperature sensor to measure the line temperature of the gas flow being monitored. The temperature is displayed in engineering units of degrees Celsius (°C). The flow controllers use the temperature of the gas in the calculation of the mass flow rate. This parameter is located in the upper middle portion of the display under “°C”. This parameter can be moved to the primary display by pushing the top center button above “°C”.

Volumetric Flow Rate: The volumetric flow rate is determined using the Flow Measurement Operating Principle described on page 25. This parameter is located in the lower left corner of the display over “Volume”. This parameter can be moved to the primary display by pushing the “Volume” button (lower left). In order to get an accurate volumetric flow rate, the gas being measured must be selected (see Gas Select Mode). This is important because the device calculates the flow rate based on the viscosity of the gas at the measured temperature. If the gas being measured is not what is selected, an incorrect value for the viscosity of the gas will be used in the calculation of flow, and the resulting output will be inaccurate in direct proportion to the ratio between the two gases viscosities.

Mass Flow Rate: The mass flow rate is the volumetric flow rate corrected to a standard temperature and pressure (typically 14.696 psia and 25°C). This parameter is located in the lower middle portion of the display over “Mass”. This parameter can be moved to the primary display by pushing the button located below “Mass” (bottom center). The controllers uses the measured temperature and the measured absolute pressure to calculate what the flow rate would be if the gas pressure was at 1 atmosphere and the gas temperature was 25°C. This allows a solid reference point for comparing one flow to another.

Flashing Error Message: Our flow meters and controllers display an error message (MOV = mass overrange, VOV = volumetric overrange, POV = pressure overrange, TOV = temperature overrange) when a measured parameter exceeds the range of the sensors in the device. When any item flashes on the display, neither the flashing parameter nor the mass flow measurement is accurate. Reducing the value of the flashing parameter to within specified limits will return the unit to normal operation and accuracy.

Select Menu Mode

Pushing “Mode” once will bring up the “Select Menu” display. Push the button nearest your selection to go to the corresponding screen. Push “Mode” again to return to the Main Mode display. (**Note:** *If your controller was ordered with Totalizing Mode option (page 43), pushing the “Mode” button once will bring up the “Totalizing Mode” display. Pushing “Mode” a second time will bring up the “Select Menu” display.*)

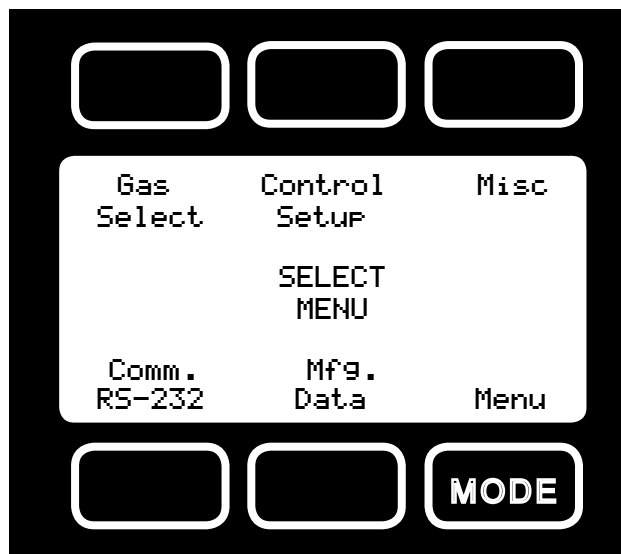

Figure 7. Select Menu Display

Control Setup Mode

The Control Setup Mode is accessed by pressing the center button above “Control Setup” on the Select Menu display (Fig.7) This mode allows the user to set up most parameters commonly associated with PID control. Alicat Scientific flow controllers allow the user to select how the set-point is to be conveyed to the controller, what that set-point is if control is local, and what the Proportional and Differential terms of the PID control loop will be. The UP and DOWN buttons for adjusting variables can be held down for higher speed adjustment or pressed repeatedly for fine adjustment.

Input – Alicat Scientific Flow Controllers normally ship defaulted to analog control as indicated in Figure 8. To change how the set-point will be conveyed to the controller push the button in the upper right hand corner just above the dynamic label “Input” until the arrow is directly in front of the desired option. The controller will ignore any set-point except that of the selected input and it will remember which input is selected even if the power is disconnected.

Analog refers to a remote analog set-point applied to Pin 4 of the Mini-DIN connector as described in the installation section of this manual. To determine what type of analog set-point your controller was ordered with, refer to the Calibration Data Sheet that was included with your controller. 0-5 Vdc is standard unless ordered otherwise. Note that if nothing is connected to Pin 4, and the controller is set for analog control, the set-point will float. **CAUTION! NEVER LEAVE A CONTROLLER WITH ANY NON-ZERO SET-POINT IF NO PRESSURE IS AVAILABLE TO MAKE FLOW. THE CONTROLLER WILL APPLY FULL POWER TO THE VALVE IN AN ATTEMPT TO REACH THE SET-POINT. WHEN THERE IS NO FLOW, THIS CAN MAKE THE VALVE VERY HOT!**

Serial refers to a remote digital RS-232 set-point applied via a serial connection to a computer or PLC as described in the Installation and RS-232 sections of this manual. **CAUTION! NEVER LEAVE A CONTROLLER WITH ANY NON-ZERO SET-POINT IF NO PRESSURE IS AVAILABLE TO MAKE FLOW. THE CONTROLLER WILL APPLY FULL POWER TO THE VALVE IN AN ATTEMPT TO REACH THE SET-POINT. WHEN THERE IS NO FLOW, THIS CAN MAKE THE VALVE VERY HOT!**

Local refers to a set-point applied directly at the controller. For more information on changing the set-point locally refer to the heading “Select” below. Local input must be selected prior to attempting to change the set-point locally. **CAUTION! NEVER LEAVE A CONTROLLER WITH ANY NON-ZERO SET-POINT IF NO PRESSURE IS AVAILABLE TO MAKE FLOW. THE CONTROLLER WILL APPLY FULL POWER TO THE VALVE IN AN ATTEMPT TO REACH THE SET-POINT. WHEN THERE IS NO FLOW, THIS CAN MAKE THE VALVE VERY HOT!**

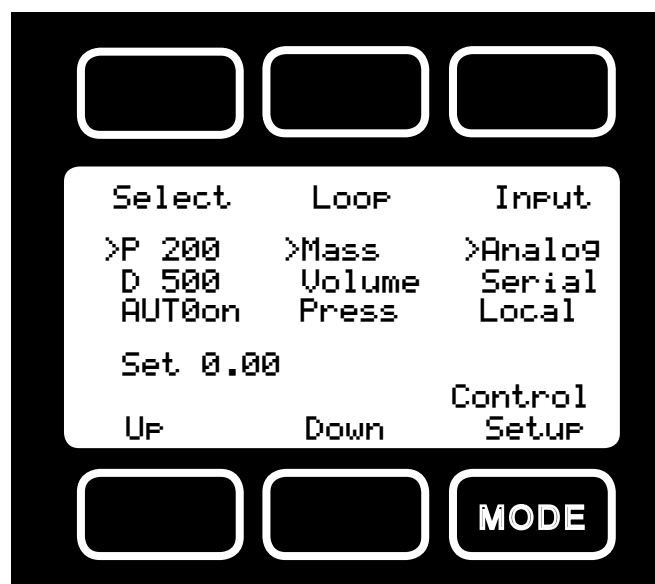

Figure 8. MC Series Control Setup Display

Loop—The selection of what variable to close the loop on is a feature unique to these mass flow controllers. When the mass flow controller is supplied with the control valve upstream of the electronics portion of the system, the unit can be set to control on outlet pressure (absolute pressures only) or volumetric flow rate, instead of mass flow rate. Repeatedly pressing the button adjacent to the word “Loop” on the control setup screen will change what variable is controlled. The change from mass to volume can usually be accomplished without much, if any, change in the P and D settings. When you change from controlling flow to controlling pressure, sometimes fairly radical changes must be made to these variables. **Note:** Full scale pressure is normally 160PSIA. *Consult the factory if you are having difficulties with this procedure.*

Select – To avoid accidental changing of the PID loop parameters or the set-point, the Control Setup mode defaults with the selector on a null position. To change the set-point or the P and D PID loop parameters, push the button in the upper left corner just above the dynamic label “Select” until the selection arrow is pointing to the parameter you wish to change. When the parameter you wish to change is selected, it may be adjusted up or down with the buttons under the display below the dynamic labels “Up” and “Down”. Press the buttons repeatedly to make slow adjustments or hold them down to make fast adjustments.

P refers to the Proportional term of the PID loop. Before changing this parameter, it is good practice to write down the initial value so that it can be returned to the factory settings if necessary.

D refers to the Differential term of the PID loop. Before changing this parameter, it is good practice to write down the initial value so that it can be returned to the factory settings if necessary.

AUTOon / AUTOoff refers to the standard auto-tare or “auto-zero” feature. It is recommended that the controller be left in the default auto-tare ON mode unless your specific application requires that it be turned off. The auto-tare feature automatically tares (takes the detected signal as zero) the unit when it receives a zero set-point for more than two seconds. A zero set-point results in the closing of the valve and a known “no flow” condition. This feature helps to make the device more accurate by periodically removing any cumulative errors associated with drift.

Set refers to the Set-Point. This parameter may only be changed if “Local” is selected as the Input. See above for information on selecting the input. Using the UP and DOWN buttons, the set-point may be adjusted between zero and the full-scale range of the controller. **CAUTION! NEVER LEAVE A CONTROLLER WITH ANY NON-ZERO SET-POINT IF NO PRESSURE IS AVAILABLE TO MAKE FLOW. THE CONTROLLER WILL APPLY FULL POWER TO THE VALVE IN AN ATTEMPT TO REACH THE SET-POINT. WHEN THERE IS NO FLOW, THIS CAN MAKE THE VALVE VERY HOT!**

Gas Select Mode

The gas select mode is accessed by pressing the button above “Gas Select” on the Select Menu display. The screen will appear as shown in Figure 9.

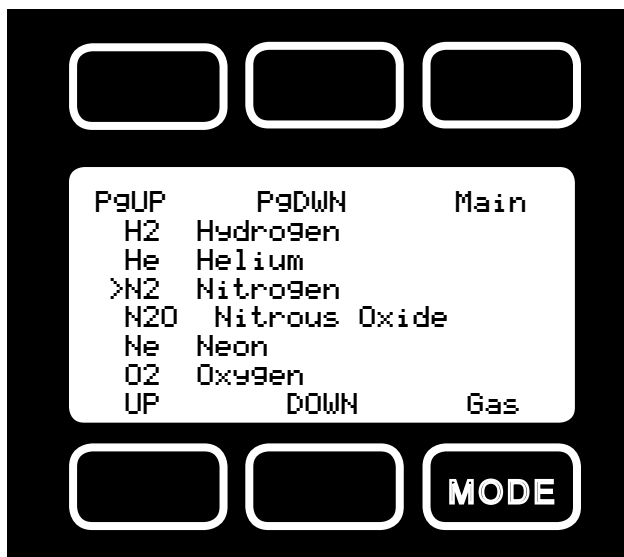

Figure 9. Gas Select Display

The selected gas is displayed on the default main mode screen as shown in Figure 6, and is indicated by the arrow in the Gas Select Mode screen in Figure 9. To change the selected gas, use the buttons under “UP” and “DOWN” or above “PgUP” and “PgDWN” to position the arrow in front of the desired gas. When the mode is cycled back to the Main Mode, the selected gas will be displayed on the main screen. (**Note:** *Gas Select Mode may not be available for units ordered for use with a custom gas or blend.*)

Communication Select Mode

The Communication Select mode is accessed by pressing the button below “Comm. RS-232” on the Select Menu display. The screen will appear as shown in Figure 10.



Figure 10. Communication Select Display

Unit ID – Valid unit identifiers are letters A-Z and @ (see **Note** below). This identifier allows the user to assign a unique address to each device so that multiple units can be connected to a single RS-232 port on a computer. The Communication Select Mode allows you to view and/or change a unit’s unique address. To change the unit ID address, press the “Select” button in the upper left corner of the display until the cursor arrow is in front of the word “Unit ID”. Then, using the UP and DOWN buttons at the bottom of the display, change the unit ID to the desired letter. **Any ID change will take effect when the Communication Select Screen is exited by pushing the MODE button.**

Note: When the symbol @ is selected as the unit ID, the device will go into streaming mode when the Communication Select Mode is exited by pushing the MODE button. See RS-232 Communications (page 21) for information about the streaming mode.

Baud – The baud rate (bits per second) determines the rate at which data is passed back and forth between the instrument and the computer. Both devices must send/receive at the same baud rate in order for the devices to communicate via RS-232. The default baud rate for these devices is 19200 baud, sometimes referred to as 19.2K baud. To change the baud rate in the Communication Select Mode, press the “Select” button in the upper left corner of the display until the cursor arrow is in front of the word “Baud”. Then, using the UP and DOWN buttons at the bottom of the display, select the required baud rate to match your computer or PLC. The choices are 38400, 19200, 9600, or 2400 baud. **Any baud rate change will not take effect until power to the unit is cycled.**

Data Rate – Changing the Data Rate affects the rate at which the instrument dumps its data. Slow is ½ the Fast rate. The speed of the Fast rate is determined by the selected baud rate. It is sometimes desirable to reduce the data rate if the communication speed bogs down the computer’s processor (as is not uncommon in older laptops), or to reduce the size of data files collected in the streaming mode. To change the data rate in the Communication Select Mode, press the “Select” button in the upper left corner of the display until the cursor arrow is in front of the word “Data Rate”. Then, using the UP and DOWN buttons at the bottom of the display, select either Fast or Slow. **Any data rate change will be effective immediately upon changing the value between Fast and Slow.**

Manufacturer Data Mode

“Manufacturer Data” is accessed by pressing the “Mfg. Data” button on the Select Menu display (Figure 11). The “Mfg 1” display shows the name and telephone number of the manufacturer. The “Mfg 2” display shows important information about your flow meter including the model number, serial number, and date of manufacture.

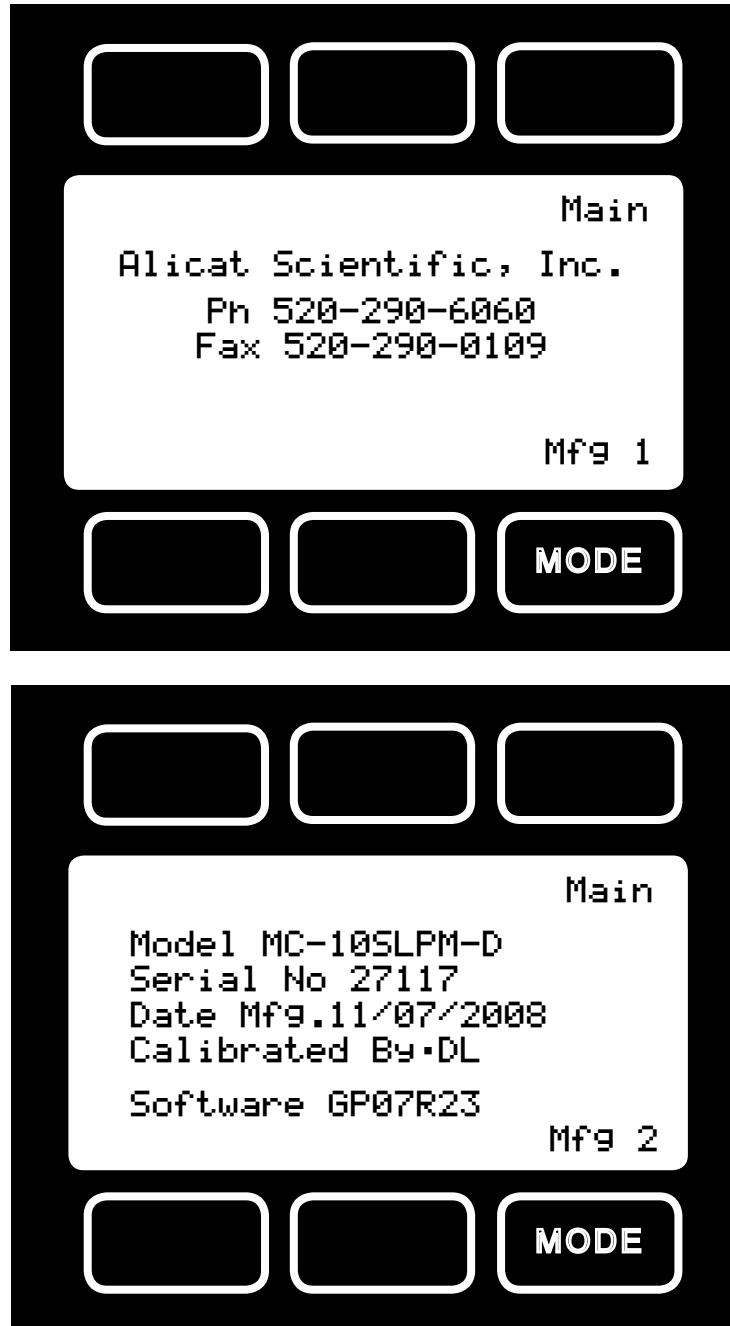

Figure 11. Manufacturer Data Displays

Miscellaneous Mode

The Miscellaneous mode is accessed by pressing the button above the “Misc” label in the upper right hand corner of the Select Menu display. The screen will appear as shown in Figure 12. Push the button above “Select” to move the cursor even with the item you wish to adjust. Then use the “UP” and “DOWN” buttons to make the adjustment.

NOTE: All Miscellaneous changes are recorded when you exit the Miscellaneous display.

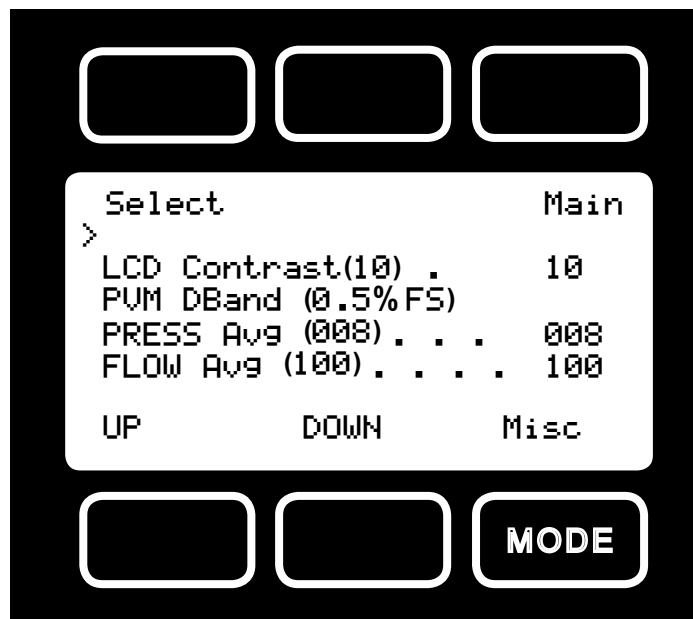

Figure 12. Miscellaneous Display

LCD Contrast: The Liquid Crystal Display Contrast can be adjusted between 0 and 30 with zero being the lightest contrast and 30 being the darkest contrast. To change the contrast, press the “Select” button in the upper left hand corner of the display until the cursor arrow is in front of the words “LCD Contrast (X)”. Then using the UP and DOWN buttons at the bottom of the display, change the contrast value as desired. The change is immediate and the effect can be monitored as the value is changed.

Display Zero Deadband: Zero deadband refers to a value below which the display simply jumps to zero. This deadband is often desired to prevent electrical noise from showing up on the display as minor flows or pressures that do not actually exist, especially in high noise (electrical) environments. This display deadband does not affect the analog or digital signal outputs — there is no zero deadband on the output signals. The display zero deadband can be adjusted between 0 and 3.2% of the Full Scale (FS) of the sensor. PVM refers to Pressure, Volumetric Flow, and Mass Flow, the three parameters to which the deadband applies. To adjust the display zero deadband, press the “Select” button in the upper left hand corner of the display until the cursor arrow is in front of the words “PVM DBand (X %F.S.)”. Then using the UP and DOWN buttons at the bottom of the display, change the display zero deadband value as desired.

Pressure Averaging: It is sometimes advantageous to apply an averaging factor to the pressure output (and display) to make it easier to read and interpret rapidly fluctuating pressures. Pressure averaging can be adjusted between 1 (no averaging) and 256 (maximum averaging). This is a geometric running average where the number between 1 and 256 can be considered very roughly equivalent to the response time constant in milliseconds. This can be very effective at “smoothing” high frequency process oscillations such as those caused by diaphragm pumps. To adjust the pressure averaging, press the “Select” button in the upper left hand corner of the display until the cursor arrow is in front of the words “PRESS Avg (XXX)”. Then using the UP and DOWN buttons at the bottom of the display, change the pressure averaging value as desired.

Flow Averaging: It is sometimes advantageous to apply an averaging factor to the flow output (and display) to make it easier to read and interpret rapidly fluctuating flows. Flow averaging can be adjusted between 1 (no averaging) and 256 (maximum averaging). This is a geometric running average where the number between 1 and 256 can be considered very roughly equivalent to the response time constant in milliseconds. This can be very effective at “smoothing” high frequency process oscillations such as those caused by diaphragm pumps. To adjust the flow averaging, press the “Select” button in the upper left hand corner of the display until the cursor arrow is in front of the words “FLOW Avg (XXX)”. Then using the UP and DOWN buttons at the bottom of the display, change the flow averaging value as desired.

MCV Controller Operating Notes

Alicat's MCV mass flow controller is equipped with an integrated Swagelok® positive shutoff valve.

The normally closed valve is air actuated and will remain closed until it is connected to an air source supplying between 60 and 120 psig of air pressure.

Once the appropriate amount of air pressure is supplied to the shutoff valve, it will open, allowing flow through the mass controller. Air pressure must be removed from the shutoff valve in order for the valve to close.

A common method for actuating the shutoff valve incorporates a three-way solenoid valve (Figure 13). Three-way solenoid valves can be obtained in a variety of configurations to best match your process variables.

Air pressure is applied to one side of the solenoid valve while the other side of the solenoid is left open to atmosphere.

When the solenoid is energized, air pressure is delivered to the shutoff valve, allowing it to open.

When the solenoid is returned to a relaxed state, air pressure is removed from the shutoff valve, allowing it to close. The air pressure is vented to atmosphere.

Solenoid valves can be ordered from Alicat Scientific for use with the MCV series mass flow controller.

Note: All standard MC Series device features and functions are available on the MCV Series and operate in accordance with the standard MC Series operating instructions.

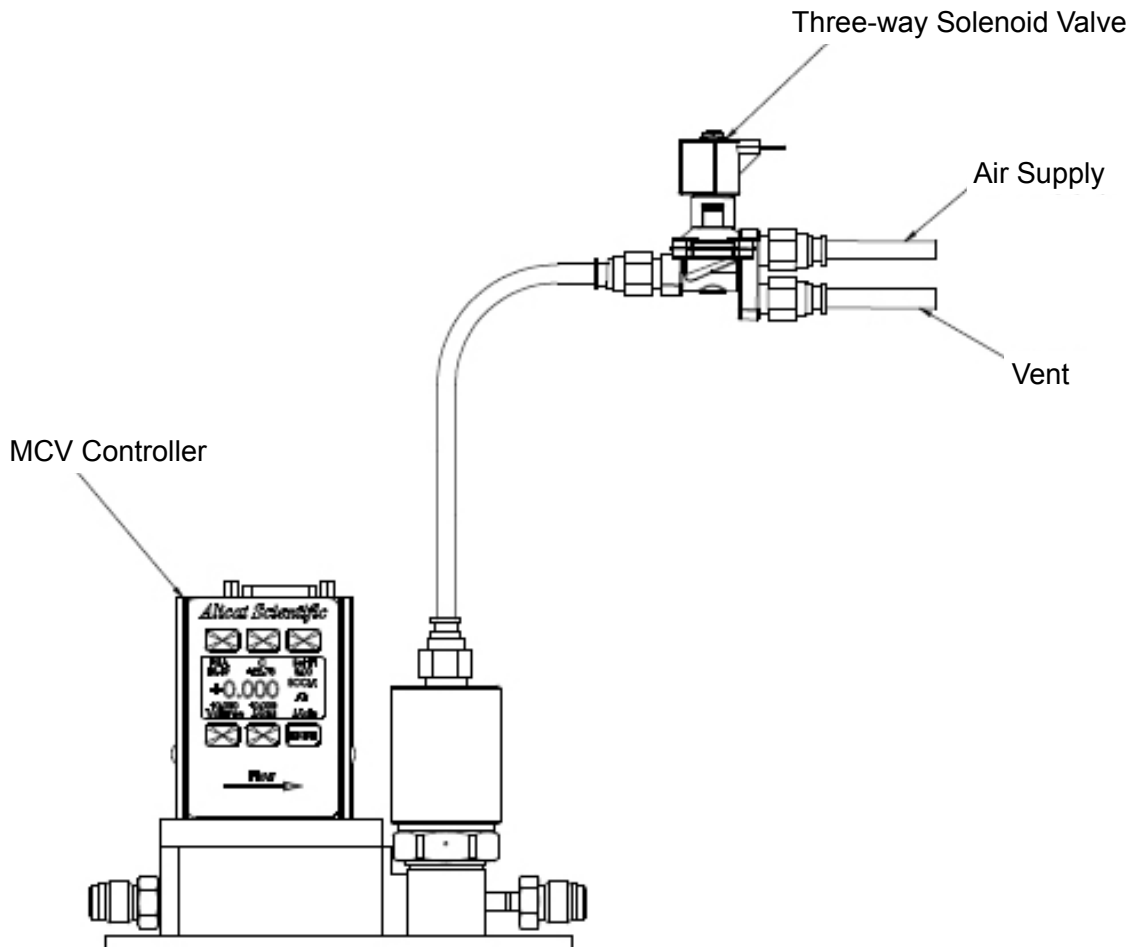

Figure 13. MCV controller and three-way solenoid valve.

RS-232 Output and Input

Configuring HyperTerminal®:

1. Open your HyperTerminal® RS-232 terminal program (installed under the “Accessories” menu on all Microsoft Windows® operating systems).
2. Select “Properties” from the file menu.
3. Click on the “Configure” button under the “Connect To” tab. Be sure the program is set for: 19,200 baud (or matches the baud rate selected in the RS-232 communications menu on the controller) and an 8-N-1-None (8 Data Bits, No Parity, 1 Stop Bit, and no Flow Control) protocol.
4. Under the “Settings” tab, make sure the Terminal Emulation is set to ANSI or Auto Detect.
5. Click on the “ASCII Setup” button and be sure the “Send Line Ends with Line Feeds” box is not checked and the “Echo Typed Characters Locally” box and the “Append Line Feeds to Incoming Lines” boxes are checked. Those settings not mentioned here are normally okay in the default position.
6. Save the settings, close HyperTerminal® and reopen it.

In Polling Mode, the screen should be blank except the blinking cursor. In order to get the data streaming to the screen, hit the “Enter” key several times to clear any extraneous information. Type “* @= @” followed by “Enter” (or using the RS-232 communication select menu, select @ as identifier and exit the screen). If data still does not appear, check all the connections and com port assignments.

Changing From Streaming to Polling Mode:

When the meter is in the Streaming Mode, the screen is updated approximately 10-60 times per second (depending on the amount of data on each line) so that the user sees the data essentially in real time. It is sometimes desirable, and necessary when using more than one unit on a single RS-232 line, to be able to poll the unit.

In Polling Mode the unit measures the flow normally, but only sends a line of data when it is “polled”. Each unit can be given its own unique identifier or address. Unless otherwise specified each unit is shipped with a default address of capital A. Other valid addresses are B thru Z.

Once you have established communication with the unit and have a stream of information filling your screen:

1. Type * @=A followed by “Enter” (or using the RS-232 communication select menu, select A as identifier and exit the screen) to stop the streaming mode of information. Note that the flow of information will not stop while you are typing and you will not be able to read what you have typed. Also, the unit does not accept a backspace or delete in the line so it must be typed correctly. If in doubt, simply hit enter and start again. If the unit does not get exactly what it is expecting, it will ignore it. If the line has been typed correctly, the data will stop.
2. You may now poll the unit by typing A followed by “Enter”. This does an instantaneous poll of unit A and returns the values once. You may type A “Enter” as many times as you like. Alternately you could resume streaming mode by typing * @= @ followed by “Enter”. Repeat step 1 to remove the unit from the streaming mode.
3. To assign the unit a new address, type * @=New Address, e.g. * @=B. Care should be taken not to assign an address to a unit if more than one unit is on the RS232 line as all of the addresses will be reassigned. Instead, each should be individually attached to the RS-232 line, given an address, and taken off. After each unit has been given a unique address, they can all be put back on the same line and polled individually.

Sending a Set-point via RS-232: To send a set-point via RS-232, “Serial” must be selected under the “Input” list in the control set up mode. To give controllers a set-point, or change an existing point, simply type in a number between 0 and 65535 (2% over range), where 64000 denotes full-scale flow rate, and hit “Enter”. The set-point column and flow rates should change accordingly. If they do not, try hitting “Enter” a couple of times and repeating your command. The formula for performing a linear interpolation is as follows:

$$\text{Value} = (\text{Desired Set-point} \times 64000) / \text{Full Scale Flow Range}$$

For example, if your device is a 100 SLPM full-scale unit and you wish to apply a set-point of 35 SLPM you would enter the following value:

$$22400 = (35 \text{ SLPM} \times 64000) / 100 \text{ SLPM}$$

If the controller is in polling mode as described in *Changing from Streaming Mode to Polling Mode*, the set-point must be preceded by the address of the controller. For example, if your controller has been given an address of D, the set-point above would be sent by typing:

D22400 followed by “Enter”

To adjust the Proportional and Differential (P&D) terms via RS-232:

Type *@=A followed by “Enter” to stop the streaming mode of information.

To adjust the “P” or proportional term of the PID controller, type *R21 followed by “Enter”.

Gas Select – The selected gas can be changed via RS-232 input. To change the selected gas, enter the following commands:

In Streaming Mode: `$$#<Enter>`

In Polling Mode: `Address$$#<Enter>` (e.g. `B$$#<Enter>`)

Where # is the number of the gas selected from the table below. Note that this also corresponds to the gas select menu on the flow controller screen:

#	GAS	
0	Air	Air
1	Argon	Ar
2	Methane	CH4
3	Carbon Monoxide	CO
4	Carbon Dioxide	CO2
5	Ethane	C2H6
6	Hydrogen	H2
7	Helium	He
8	Nitrogen	N2
9	Nitrous Oxide	N2O
10	Neon	Ne
11	Oxygen	O2
12	Propane	C3H8
13	normal-Butane	n-C4H10
14	Acetylene	C2H2
15	Ethylene	C2H4
16	iso-Butane	i-C2H10
17	Krypton	Kr
18	Xenon	Xe
19	Sulfur Hexafluoride	SF6
20	75% Argon / 25% CO2	C-25
21	90% Argon / 10% CO2	C-10
22	92% Argon / 8% CO2	C-8
23	98% Argon / 2% CO2	C-2
24	75% CO2 / 25% Argon	C-75
25	75% Argon / 25% Helium	A-75
26	75% Helium / 25% Argon	A-25
27	90% Helium / 7.5% Argon / 2.5% CO2 (Praxair - Helistar® A1025)	A1025
28	90% Argon / 8% CO2 / 2% Oxygen (Praxair - Stargon® CS)	Star29
29	95% Argon / 5% Methane	P-5

For example, to select Propane, enter: `$$12<Enter>`

The computer will respond by reading the current value for register 21 between 0-65535. It is good practice to write this value down so you can return to the factory settings if necessary. Enter the value you wish to try by writing the new value to register 21. For example, if you wished to try a “P” term of 220, you would type *W21=**220** followed by “Enter” where the bold number denotes the new value.

The computer will respond to the new value by confirming that 21=220. To see the effect of the change you may now poll the unit by typing A followed by “Enter”. This does an instantaneous poll and returns the values once. You may type A “Enter” as many times as you like. Alternately you could resume streaming mode by typing *@=@ followed by “Enter”. Repeat step 3 to remove the unit from the streaming mode.

To adjust the “D” or proportional term of the PID controller, type *R22 followed by “Enter”.

The computer will respond by reading the current value for register 22 between 0-65535. It is good practice to write this value down so you can return to the factory settings if necessary. Enter the value you wish to try by writing the new value to register 22. For example, if you wished to try a “D” term of 25, you would type *W22=**25** followed by “Enter” where the bold number denotes the new value.

The computer will respond to the new value by confirming that 22=25. To see the effect of the change you may now poll the unit by typing A followed by “Enter”. This does an instantaneous poll and returns the values once. You may type A “Enter” as many times as you like. Alternately you could resume streaming mode by typing *@=@ followed by “Enter”. Repeat.

You may test your settings for a step change by changing the set-point. To do this type A32000 (A is the default single unit address, if you have multiple addressed units on your RS-232 line the letter preceding the value would change accordingly.) followed by “Enter” to give the unit a ½ full scale set-point. Monitor the unit’s response to the step change to ensure it is satisfactory for your needs. Recall that the “P” term controls how quickly the unit goes from one set-point to the next, and the “D” term controls how quickly the signal begins to “decelerate” as it approaches the new set-point (controls the overshoot).

Collecting Data:

The RS-232 output updates to the screen many times per second. Very short-term events can be captured simply by disconnecting (there are two telephone symbol icons at the top of the HyperTerminal® screen for disconnecting and connecting) immediately after the event in question. The scroll bar can be driven up to the event and all of the data associated with the event can be selected, copied, and pasted into Microsoft® Excel® or other spreadsheet program as described below.

For longer term data, it is useful to capture the data in a text file. With the desired data streaming to the screen, select “Capture Text” from the Transfer Menu. Type in the path and file name you wish to use. Push the start button. When the data collection period is complete, simply select “Capture Text” from the Transfer Menu and select “Stop” from the sub-menu that appears.

Data that is selected and copied, either directly from HyperTerminal® or from a text file can be pasted directly into Excel®. When the data is pasted it will all be in the selected column. Select “Text to Columns...” under the Data menu in Excel® and a Text to Columns Wizard (dialog box) will appear. Make sure that “Fixed Width” is selected under Original Data Type in the first dialog box and click “Next”. In the second dialog box, set the column widths as desired, but the default is usually acceptable. Click on “Next” again. In the third dialog box, make sure the column data format is set to “General”, and click “Finish”. This separates the data into columns for manipulation and removes symbols such as the plus signs from the numbers. Once the data is in this format, it can be graphed or manipulated as desired.

For extended term data capture see: “Sending a Simple Script to HyperTerminal®” on page 24.

Data Format:

The data stream on the screen represents the flow parameters of the main mode in the units shown on the display.

For mass flow controllers, there are 6 columns of data representing pressure, temperature, volumetric flow, mass flow and the selected gas. The first column is absolute pressure (normally in PSIA), the second column is temperature (normally in °C), the third column is volumetric flow rate (in the units specified at time of order and shown on the display), and the fourth column is mass flow (also in the units specified at time of order and shown on the display). For instance, if the meter was ordered in units of SCFM, the display on the meter would read 2.004 SCFM and the last two columns of the output below would represent volumetric flow and mass flow in CFM and SCFM respectively.

```
+014.70 +025.00 +02.004 +02.004 2.004 Air  
+014.70 +025.00 +02.004 +02.004 2.004 Air  
+014.70 +025.00 +02.004 +02.004 2.004 Air  
+014.70 +025.00 +02.004 +02.004 2.004 Air  
+014.70 +025.00 +02.004 +02.004 2.004 Air  
+014.70 +025.00 +02.004 +02.004 2.004 Air
```

MC Series Mass Flow Controller Data Format

Sending a Simple Script File to HyperTerminal®

It is sometimes desirable to capture data for an extended period of time. Standard streaming mode information is useful for short term events, however, when capturing data for an extended period of time, the amount of data and thus the file size can become too large very quickly. Without any special programming skills, the user can use HyperTerminal® and a text editing program such as Microsoft® Word® to capture text at user defined intervals.

1. Open your text editing program, MS Word for example.
2. Set the cap lock on so that you are typing in capital letters.
3. Beginning at the top of the page, type A<Enter> repeatedly. If you're using MS Word, you can tell how many lines you have by the line count at the bottom of the screen. The number of lines will correspond to the total number of times the flow device will be polled, and thus the total number of lines of data it will produce.

For example: A

A
A
A
A
A

will get a total of six lines of data from the flow meter, but you can enter as many as you like.

The time between each line will be set in HyperTerminal.

4. When you have as many lines as you wish, go to the File menu and select save. In the save dialog box, enter a path and file name as desired and in the "Save as Type" box, select the plain text (.txt) option. It is important that it be saved as a generic text file for HyperTerminal to work with it.
5. Click Save.
6. A file conversion box will appear. In the "End Lines With" drop down box, select CR Only. Everything else can be left as default.
7. Click O.K.
8. You have now created a "script" file to send to HyperTerminal. Close the file and exit the text editing program.
9. Open HyperTerminal and establish communication with your flow device as outlined in the manual.
10. Set the flow device to Polling Mode as described in the manual. Each time you type A<Enter>, the meter should return one line of data to the screen.
11. Go to the File menu in HyperTerminal and select "Properties".
12. Select the "Settings" tab.
13. Click on the "ASCII Setup" button.
14. The "Line Delay" box is defaulted to 0 milliseconds. This is where you will tell the program how often to read a line from the script file you've created. 1000 milliseconds is one second, so if you want a line of data every 30 seconds, you would enter 30000 into the box. If you want a line every 5 minutes, you would enter 300000 into the box.
15. When you have entered the value you want, click on OK and OK in the Properties dialog box.
16. Go the Transfer menu and select "Send **Text** File..." (NOT Send File...).
17. Browse and select the text "script" file you created.
18. Click Open.
19. The program will begin "executing" your script file, reading one line at a time with the line delay you specified and the flow device will respond by sending one line of data for each poll it receives, when it receives it.

You can also capture the data to another file as described in the manual under "Collecting Data". You will be simultaneously sending it a script file and capturing the output to a separate file for analysis.

Operating Principle

All M Series Gas Flow Meters (and MC Series Gas Flow Controllers) are based on the accurate measurement of volumetric flow. The volumetric flow rate is determined by creating a pressure drop across a unique internal restriction, known as a Laminar Flow Element (LFE), and measuring differential pressure across it. The restriction is designed so that the gas molecules are forced to move in parallel paths along the entire length of the passage; hence laminar (streamline) flow is established for the entire range of operation of the device. Unlike other flow measuring devices, in laminar flow meters the relationship between pressure drop and flow is linear. The underlying principle of operation of the 16 Series flow meters is known as the Poiseuille Equation:

$$Q = (P_1 - P_2) \pi r^4 / 8 \eta L \quad (\text{Equation 1})$$

Where:

Q	=	Volumetric Flow Rate
P ₁	=	Static pressure at the inlet
P ₂	=	Static pressure at the outlet
r	=	Radius of the restriction
η	=	(eta) absolute viscosity of the fluid
L	=	Length of the restriction

Since π, r and L are constant; Equation 1 can be rewritten as:

$$Q = K (\Delta P / \eta) \quad (\text{Equation 2})$$

Where K is a constant factor determined by the geometry of the restriction. Equation 2 shows the linear relationship between volumetric flow rate (Q) differential pressure (ΔP) and absolute viscosity (η) in a simpler form.

Gas Viscosity: In order to get an accurate volumetric flow rate, the gas being measured must be selected (see Gas Select Mode, page 14). This is important because the device calculates the flow rate based on the viscosity of the gas at the measured temperature. If the gas being measured is not what is selected, an incorrect value for the viscosity of the gas will be used in the calculation of flow, and the resulting output will be inaccurate in direct proportion to the difference in the two gases viscosities.

Gas viscosity, and thus gas composition, can be very important to the accuracy of the meter. Anything that has an effect on the gas viscosity (e.g. water vapor, odorant additives, etc.) will have a direct proportional effect on the accuracy. Selecting methane and measuring natural gas for instance, will result in a fairly decent reading, but it is not highly accurate (errors are typically < 0.6%) because natural gas contains small and varying amounts of other gases such as butane and propane that result in a viscosity that is somewhat different than pure methane.

Absolute viscosity changes very little with pressure (within the operating ranges of these meters) therefore a true volumetric reading does not require a correction for pressure. Changes in gas temperature do affect viscosity. For this reason, the M Series internally compensates for this change.

Other Gases: M Series Flow Meters can easily be used to measure the flow rate of gases other than those listed as long as “non-corrosive” gas compatibility is observed. For example, a flow meter that has been set for air can be used to measure the flow of argon.

The conversion factor needed for measuring the flow of different gases is linear and is simply determined by the ratio of the absolute viscosity of the gases. This factor can be calculated as follows:

$$Q_{og} = Q_1 [\eta_1 / \eta_{og}]$$

Where:

Q_1	=	Flow rate indicated by the flow meter
η_1	=	Viscosity of the calibrated gas at the measured temp.
Q_{og}	=	Flow rate of the alternate gas
η_{og}	=	Viscosity of the alternate gas at the measured temp.

Say we have a meter set for air and we want to flow argon through it. With argon flowing through the meter, the display reads 110 SLPM. For ease of calculation, let us say the gas temperature is 25°C. What is the actual flow of argon?

Q_{og}	=	Actual Argon Flow Rate
Q_1	=	Flow rate indicated by meter (110 SLPM)
η_1	=	Viscosity of gas selected or calibrated for by the meter at the measured temp.
η_{og}	=	Viscosity of gas flowing through the meter at the measured temp.

At 25°C, the absolute viscosity of Air (η_1) is 184.918 micropoise.

At 25°C, the absolute viscosity of Argon (η_{og}) is 225.593 micropoise.

Q_{og}	=	$Q_1 (\eta_1 / \eta_{og})$
Q_{og}	=	110 SLPM (184.918 / 225.593)
Q_{og}	=	90.17 SLPM

So, the actual flow of Argon through the meter is 90.17 SLPM. As you can see, because the Argon gas is more viscous than the Air the meter is set for, the meter indicates a higher flow than the actual flow.

A good rule of thumb is: “At a given flow rate, the higher the viscosity, the higher the indicated flow.”

Volume Flow vs. Mass Flow: At room temperature and low pressures the volumetric and mass flow rate will be nearly identical, however, these rates can vary drastically with changes in temperature and/or pressure because the temperature and pressure of the gas directly affects the volume. For example, assume a volumetric flow reading was used to fill balloons with 250 mL of helium, but the incoming line ran near a furnace that cycled on and off, intermittently heating the incoming helium. Because the volumetric meter simply measures the volume of gas flow, all of the balloons would initially be the same size. However, if all the balloons are placed in a room and allowed to come to an equilibrium temperature, they would generally all come out to be different sizes. If, on the other hand, a mass flow reading were used to fill the balloons with 250 standard mL of helium, the resulting balloons would initially be different sizes, but when allowed to come to an equilibrium temperature, they would all turn out to be the same size.

This parameter is called corrected mass flow because the resulting reading has been compensated for temperature and pressure and can therefore be tied to the mass of the gas. Without knowing the temperature and pressure of the gas and thus the density, the mass of the gas cannot be determined.

This reduces to: $P_a V_a / Z_a T_a = P_s V_s / Z_s T_s$, eliminating R and n.

Alicat mass flow meters model gas flows based upon the non-ideal gas characteristics of the calibrated gas. The flow corrections are normally made to 25 C and 14.696 PSIA and the compressibility factor of the gas under those conditions. This allows the user to multiply the mass flow rate by the density of the real gas at those standard conditions to get the mass flow rate in grams per minute.

Because we incorporate the compressibility factor into our 'full gas model'; attempts to manually compute mass flows from only the P, V, and T values shown on the display will sometimes result in modest errors.

Note: Although the correct units for mass are expressed in grams, kilograms, etc. it has become standard that mass flow rate is specified in SLPM (standard liters / minute), SCCM (standard cubic centimeters / minute) or SmL/M (standard milliliters / minute).

This means that mass flow rate is calculated by normalizing the volumetric flow rate to some standard temperature and pressure (STP). By knowing the density at that STP, one can determine the mass flow rate in grams per minute, kilograms per hour, etc.

STP is usually specified as the sea level conditions; however, no single standard exists for this convention. Examples of common reference conditions include:

0°C	and	14.696 PSIA
25°C	and	14.696 PSIA
0°C	and	760 torr (mmHG)
70°F	and	14.696 PSIA
68°F	and	29.92 inHG
20°C	and	760 torr (mmHG)

MC Series Flow Controllers reference 25°C and 14.696 PSIA (101.32kPa) - unless ordered otherwise and specified in the notes field of the calibration sheet.

Standard Gas Data Tables: Those of you who have older Alicat products (manufactured before October 2005) may notice small discrepancies between the gas property tables of your old and new units. Alicat Scientific, Inc. has incorporated the latest data sets from NIST (including their REFPROP 7 data) in our products' built-in gas property models. Be aware that calibrators that you may be spot checking against may be using older data sets such as the widely distributed Air Liquide data. This may generate apparent calibration discrepancies of up to 0.6% of reading on well behaved gases and as much as 3% of reading on some gases such as propane and butane, unless the standard was directly calibrated on the gas in question. As the older standards are phased out of the industry, this difference in readings will cease to be a problem. If you see a difference between the Alicat meter and your in-house standard, in addition to calling Alicat Scientific at (520) 290-6060, call the manufacturer of your standard for clarification as to which data set they used in their calibration. This comparison will in all likelihood resolve the problem.

Gas Number	Short Form	Long Form	Viscosity* 25 deg C 14.696 PSIA	Density** 25 deg C 14.696 PSIA	Compressibility 25 deg C 14.696 PSIA
0	Air	Air	184.918	1.1840	0.9997
1	Ar	Argon	225.593	1.6339	0.9994
2	CH4	Methane	111.852	0.6569	0.9982
3	CO	Carbon Monoxide	176.473	1.1453	0.9997
4	CO2	Carbon Dioxide	149.332	1.8080	0.9949
5	C2H6	Ethane	93.540	1.2385	0.9924
6	H2	Hydrogen	89.153	0.08235	1.0006
7	He	Helium	198.457	0.16353	1.0005
8	N2	Nitrogen	178.120	1.1453	0.9998
9	N2O	Nitrous Oxide	148.456	1.8088	0.9946
10	Ne	Neon	311.149	0.8246	1.0005
11	O2	Oxygen	204.591	1.3088	0.9994
12	C3H8	Propane	81.458	1.8316	0.9841
13	n-C4H10	normal-Butane	74.052	2.4494	0.9699
14	C2H2	Acetylene	104.448	1.0720	0.9928
15	C2H4	Ethylene	103.177	1.1533	0.9943
16	i-C4H10	iso-Butane	74.988	2.4403	0.9728
17	Kr	Krypton	251.342	3.4274	0.9994
18	Xe	Xenon	229.785	5.3954	0.9947
19	SF6	Sulfur Hexafluoride	153.532	6.0380	0.9887
20	C-25	75% Argon / 25% CO2	205.615	1.6766	0.9987
21	C-10	90% Argon / 10% CO2	217.529	1.6509	0.9991
22	C-8	92% Argon / 8% CO2	219.134	1.6475	0.9992
23	C-2	98% Argon / 2% CO2	223.973	1.6373	0.9993
24	C-75	75% CO2 / 25% Argon	167.451	1.7634	0.9966
25	A-75	75% Argon / 25% Helium	230.998	1.2660	0.9997
26	A-25	75% Helium / 25% Argon	234.306	0.5306	1.0002
27	A1025	90% Helium / 7.5% Argon / 2.5% CO2 (Praxair - Helistar® A1025)	214.840	0.3146	1.0003
28	Star29	90% Argon / 8% CO2 / 2% Oxygen (Praxair - Stargon® CS)	218.817	1.6410	0.9992
29	P-5	95% Argon / 5% Methane	223.483	1.5850	0.9993
*in micropoise (1 Poise = gram / (cm) (sec))			** Grams/Liter	(NIST REFPROP 7 database)	

Gas Viscosities, Densities and Compressibilities at 25° C

Gas Number	Short Form	Long Form	Viscosity* 0 deg C 14.696 PSIA	Density** 0 deg C 14.696 PSIA	Compressibility 0 deg C 14.696 PSIA
0	Air	Air	172.588	1.2927	0.9994
1	Ar	Argon	209.566	1.7840	0.9991
2	CH4	Methane	103.657	0.7175	0.9976
3	CO	Carbon Monoxide	165.130	1.2505	0.9994
4	CO2	Carbon Dioxide	137.129	1.9768	0.9933
5	C2H6	Ethane	86.127	1.3551	0.9900
6	H2	Hydrogen	83.970	0.08988	1.0007
7	He	Helium	186.945	0.17849	1.0005
8	N2	Nitrogen	166.371	1.2504	0.9995
9	N2O	Nitrous Oxide	136.350	1.9778	0.9928
10	Ne	Neon	293.825	0.8999	1.0005
11	O2	Oxygen	190.555	1.4290	0.9990
12	C3H8	Propane	74.687	2.0101	0.9787
13	n-C4H10	normal-Butane	67.691	2.7048	0.9587
14	C2H2	Acetylene	97.374	1.1728	0.9905
15	C2H4	Ethylene	94.690	1.2611	0.9925
16	i-C4H10	iso-Butane	68.759	2.6893	0.9627
17	Kr	Krypton	232.175	3.7422	0.9991
18	Xe	Xenon	212.085	5.8988	0.9931
19	SF6	Sulfur Hexafluoride	140.890	6.6154	0.9850
20	C-25	75% Argon / 25% CO2	190.579	1.8309	0.9982
21	C-10	90% Argon / 10% CO2	201.897	1.8027	0.9987
22	C-8	92% Argon / 8% CO2	203.423	1.7989	0.9988
23	C-2	98% Argon / 2% CO2	208.022	1.7877	0.9990
24	C-75	75% CO2 / 25% Argon	154.328	1.9270	0.9954
25	A-75	75% Argon / 25% Helium	214.808	1.3821	0.9995
26	A-25	75% Helium / 25% Argon	218.962	0.5794	1.0002
27	A1025	90% Helium / 7.5% Argon / 2.5% CO2 (Praxair - Helistar® A1025)	201.284	0.3434	1.0002
28	Star29	90% Argon / 8% CO2 / 2% Oxygen (Praxair - Stargon® CS)	203.139	1.7918	0.9988
29	P-5	95% Argon / 5% Methane	207.633	1.7307	0.9990
*in micropoise (1 Poise = gram / (cm) (sec))			** Grams/Liter	(NIST REFPROP 7 database)	

Gas Viscosities, Densities and Compressibilities at 0° C

TROUBLESHOOTING

Display does not come on or is weak.

Check power and ground connections.

Flow reading is approximately fixed either near zero or near full scale regardless of actual line flow.

Differential pressure sensor may be damaged. Avoid installations that can subject sensor to pressure drops in excess of 10 PSID. A common cause of this problem is instantaneous application of high-pressure gas as from a snap acting solenoid valve upstream of the meter. Damage due to excessive pressure differential is not covered by warranty.

Displayed mass flow, volumetric flow, pressure or temperature is flashing and message MOV, VOV, POV or TOV is displayed:

Our flow meters and controllers display an error message (MOV = mass overrange, VOV = volumetric overrange, POV = pressure overrange, TOV = temperature overrange) when a measured parameter exceeds the range of the sensors in the device. When any item flashes on the display, neither the flashing parameter nor the mass flow measurement is accurate. Reducing the value of the flashing parameter to within specified limits will return the unit to normal operation and accuracy.

After installation, there is no flow.

Alicat Scientific MC controllers incorporate normally closed valves and require a set-point to operate. Check that your set-point signal is present and supplied to the correct pin and that the correct input is selected under the Input list in the control set up mode screen. Also check that the unit is properly grounded.

The flow lags below the set-point.

Be sure there is enough pressure available to make the desired flow rate. If either the set-point signal line and/or the output signal line is relatively long, it may be necessary to provide heavier wires (especially ground wiring) to negate voltage drops due to line wire length. An inappropriate PID tuning can also cause this symptom if the D term is too large relative to the P term.

Meter does not agree with another meter I have in line.

Volumetric meters will often not agree with one another when put in series because they are affected by pressure drops. Volumetric flow meters should not be compared to mass flow meters. Mass flow meters can be compared against one another provided there are no leaks between the two meters and they are set to the same standard temperature and pressure. Both meters must also be calibrated (or set) for the gas being measured. M Series mass flow meters are normally set to Standard Temperature and Pressure conditions of 25° C and 14.696 PSIA. Note: it is possible to special order meters with a customer specified set of standard conditions. The calibration sheet provided with each meter lists its standard conditions.

Controller is slow to react to a set-point change or imparts an oscillation to the flow.

An inappropriate PID tuning can cause these symptoms. Use at conditions considerably different than those at which the device was originally set up can necessitate a re-tuning of the PID loop.

The output signal is lower than the reading at the display.

This can occur if the output signal is measured some distance from the meter as voltage drops in the wires increase with distance. Using heavier gauge wires, especially in the ground wire, can reduce this effect.

RS-232 Serial Communications is not responding.

Check that your meter is powered and connected properly. Be sure that the port on the computer to which the meter is connected is active. Confirm that the port settings are correct per the RS-232 instructions in this manual (Check the RS-232 communications select screen for current meter readings). Close Hyperterminal® and reopen it. Reboot your PC.

Slower response than specified.

MC Series Controllers feature a programmable Geometric Running Average (GRA). Depending on the full scale range of the meter, it may have the GRA set to enhance the stability/readability of the display, which would result in slower perceived response time. Please see “Pressure Averaging” and “Flow Averaging” on page 17.

Jumps to zero at low flow.

MC Series Controllers feature a programmable zero deadband. The factory setting is usually 0.5% of full scale. This can be adjusted between NONE and 3.2% of full scale. See page 17.

Discrepancies between old and new units.

Please see “Standard Gas Data Tables” explanation on page 28.

Maintenance and Recalibration

General: MC Series Flow Controllers require minimal maintenance. They have no moving parts. The single most important thing that affects the life and accuracy of these devices is the quality of the gas being measured. The controller is designed to measure CLEAN, DRY, NON-CORROSIVE gases. A 20 micron filter (50 micron for 50LPM and up) mounted upstream of the controller is highly recommended. Moisture, oil, and other contaminants can affect the laminar flow elements and/or reduce the area that is used to calculate the flow rate. This directly affects the accuracy.

Recalibration: The recommended period for recalibration is once every year. Providing that the CLEAN, DRY, and NON-CORROSIVE mantra is observed, this periodic recalibration is sufficient. A label located on the back of the meter lists the recalibration due date. The meter should be returned to the factory for recalibration near the listed due date. Before calling to schedule a recalibration, please note the serial number on the back of the meter. The Serial Number, Model Number, and Date of Manufacture are also available on the Manufacture Data 2 display (page 16).

Cleaning: MC Series Flow Controllers require no periodic cleaning. If necessary, the outside of the controller can be cleaned with a soft dry rag. Avoid excess moisture or solvents.

For repairs, recalibrations, or recycling of this product, contact:

Alicat Scientific, Inc.
7641 N Business Park Drive
Tucson, Arizona 85743
USA
Ph. 520-290-6060
Fax 520-290-0109
email: info@alicatescientific.com
Web site: www.alicatescientific.com

Technical Data for Micro-Flow and Ultra-Low Flow Mass Flow Controllers

0 to 0.5SCCM Full Scale through 0 to 50SCCM Full Scale

The following specifications are for the standard configuration of the Alicat product. There are many low-cost customization options available.

Specification	Mass Controller	Description
Accuracy	± (0.8% of Reading + 0.2% of Full Scale)	At calibration conditions after tare
High Accuracy Option	± (0.4% of Reading + 0.2% of Full Scale)	At calibration conditions after tare
Repeatability	± 0.2%	Full Scale
Operating Range	1% to 100% Full Scale	Measure and Control
Typical Response Time	100	Milliseconds (Adjustable)
Standard Conditions (STP)	25°C & 14.696PSIA	Mass Reference Conditions
Operating Temperature	-10 to +50	°Celsius
Zero Shift	0.02%	Full Scale / °Celsius / Atm
Span Shift	0.02%	Full Scale / °Celsius / Atm
Humidity Range	0 to 100%	Non-Condensing
Controllable Flow Rate	102.4%	Full Scale
Maximum Pressure	145	PSIG
Input /Output Signal Digital	Mass Flow, VolumetricFlow, Pressure & Temperature	RS-232 Serial or PROFIBUS ¹
Input / Output Signal Analog	Mass Flow	0-5Vdc
Optional Input / Output Signal Secondary Analog	Mass Flow, Volumetric Flow, Pressure or Temperature	0-5 Vdc or 0-10Vdc or 4-20mA
Electrical Connections	8 Pin Mini-DIN or DB-15	
Supply Voltage	12 to 30 Vdc (15-30Vdc for 4-20mA outputs)	
Supply Current	0.250Amp	
Mounting Attitude Sensitivity	None	
Warm-up Time	< 1	Second
Wetted Materials ²	303 & 302 Stainless Steel, Viton®, Silicone RTV (Rubber), Glass Reinforced Nylon, Aluminum, Brass, 410 Stainless Steel, Silicon, Glass.	
1.If selecting PROFIBUS no analog signal is available. PROFIBUS units do not have the display. See page 41 for PROFIBUS specifications for PROFIBUS supply voltages and currents. 2. If your application demands a different material, please contact Application Assistance for available options.		

Mechanical Specifications

Full Scale Flow Mass Controller	Mechanical Dimensions	Process Connections ¹	Pressure Drop ² (PSID)
0.5SCCM to 50SCCM	3.9"H x 3.4"W x 1.1"D	M-5 (10-32) Female Thread*	1.0
<p>Units ≤50SCCM F.S. are shipped with M-5 (10-32) Male Buna-N O-ring face seal to 1/8" Female NPT fittings. These adaptor fittings were selected for customer convenience in process connection. It should be noted that the 1/8" Female NPT introduces additional dead volume. To minimize dead volume, please see Accessories for the M-5 (10-32) Male to 1/8"OD compression fitting.</p> <p>1. Compatible with Beswick®, Swagelok® tube, Parker®, face seal, push connect and compression adapter fittings. 2. Venting to atmosphere. Lower Pressure Drops Available, Please contact Application Assistance.</p>			

Dimensional Drawings: page 37

Technical Data for Low Flow Mass Flow Controllers

0 to 100SCCM Full Scale through 0 to 20SLPM Full Scale

The following specifications are for the standard configuration of the Alicat product. There are many low-cost customization options available.

Specification	Mass Controller	Description
Accuracy	± (0.8% of Reading + 0.2% of Full Scale)	At calibration conditions after tare
High Accuracy Option	± (0.4% of Reading + 0.2% of Full Scale)	At calibration conditions after tare
Repeatability	± 0.2%	Full Scale
Operating Range	1% to 100% Full Scale	Measure and Control
Typical Response Time	100	Milliseconds (Adjustable)
Standard Conditions (STP)	25°C & 14.696PSIA	Mass Reference Conditions
Operating Temperature	-10 to +50	°Celsius
Zero Shift	0.02%	Full Scale / °Celsius / Atm
Span Shift	0.02%	Full Scale / °Celsius / Atm
Humidity Range	0 to 100%	Non-Condensing
Controllable Flow Rate	102.4%	Full Scale
Maximum Pressure	145	PSIG
Input /Output Signal Digital	Mass Flow, Volumetric Flow, Pressure & Temperature	RS-232 Serial or PROFIBUS ²
Input / Output Signal Analog	Mass Flow	0-5Vdc
Optional Input / Output Signal Secondary Analog	Mass Flow, Volumetric Flow, Pressure or Temperature	0-5 Vdc or 0-10Vdc or 4-20mA
Electrical Connections	8 Pin Mini-DIN or DB-15	
Supply Voltage	12 to 30 Vdc (15-30Vdc for 4-20mA outputs)	
Supply Current	0.250Amp (at 12 Vdc, declining with increased supply voltage)	
Mounting Attitude Sensitivity	None	
Warm-up Time	< 1	Second
Wetted Materials ²	303 & 302 Stainless Steel, Viton®, Silicone RTV (Rubber), Glass Reinforced Nylon, Aluminum, Brass, 410 Stainless Steel, Silicon, Glass.	
1. If selecting PROFIBUS no analog signal is available. PROFIBUS units do not have the display. See page 41 for PROFIBUS specifications for PROFIBUS supply voltages and currents.		
2. If your application demands a different material, please contact Application Assistance for available options.		

Mechanical Specifications

Full Scale Flow Mass Controller	Mechanical Dimensions	Process Connections ¹	Pressure Drop ² (PSID)
100SCCM to 500SCCM	4.1"H x 3.6"W x 1.1"D	1/8" NPT Female	1.0
1SLPM			1.5
2SLPM			3.0
5SLPM			2.0
10SLPM			5.5
20SLPM			20.0
1. Compatible with Beswick®, Swagelok® tube, Parker®, face seal, push connect and compression adapter fittings.			
2. Lower Pressure Drops Available, Please contact Application Assistance.			

Technical Data for Moderate Flow Mass Flow Controllers

0 to 50SLPM Full Scale through 0 to 100SLPM Full Scale

The following specifications are for the standard configuration of the Alicat product. There are many low-cost customization options available.

Specification	Mass Controller	Description
Accuracy	± (0.8% of Reading + 0.2% of Full Scale)	At calibration conditions after tare
High Accuracy Option	± (0.4% of Reading + 0.2% of Full Scale)	At calibration conditions after tare
Repeatability	± 0.2%	Full Scale
Operating Range	1% to 100% Full Scale	Measure and Control
Typical Response Time	100	Milliseconds (Adjustable)
Standard Conditions (STP)	25°C & 14.696PSIA	Mass Reference Conditions
Operating Temperature	-10 to +50	°Celsius
Zero Shift	0.02%	Full Scale / °Celsius / Atm
Span Shift	0.02%	Full Scale / °Celsius / Atm
Humidity Range	0 to 100%	Non-Condensing
Controllable Flow Rate	102.4%	Full Scale
Maximum Pressure	145	PSIG
Input /Output Signal Digital	Mass Flow, Volumetric Flow, Pressure & Temperature	RS-232 Serial or PROFIBUS ²
Input / Output Signal Analog	Mass Flow	0-5Vdc
Optional Input / Output Signal Secondary Analog	Mass Flow, Volumetric Flow, Pressure or Temperature	0-5 Vdc or 0-10Vdc or 4-20mA
Electrical Connections	8 Pin Mini-DIN or DB-15	
Supply Voltage	24 to 30 Vdc	
Supply Current	0.750Amp	
Mounting Attitude Sensitivity	Control response somewhat sensitive to inverted operation.	
Warm-up Time	< 1	Second
Wetted Materials ²	303 & 302 Stainless Steel, Viton®, Silicone RTV (Rubber), Glass Reinforced Nylon, Aluminum, 410 & 416 Stainless Steel, Nickel, Silicon, Glass.	
1. If selecting PROFIBUS no analog signal is available. PROFIBUS units do not have the display. See page 41 for PROFIBUS specifications for PROFIBUS supply voltages and currents. 2. If your application demands a different material, please contact Application Assistance for available options.		

Mechanical Specifications

Full Scale Flow Mass Controller	Mechanical Dimensions	Process Connections ¹	Pressure Drop ² (PSID)
50SLPM	4.7"H x 7.3"W x 2.3"D	1/4" NPT Female	9.0
100SLPM			11.7
1. Compatible with Beswick®, Swagelok® tube, Parker®, face seal, push connect and compression adapter fittings. 2. Lower Pressure Drops Available, Please contact Application Assistance.			

Dimensional Drawings: page 38

Technical Data for High Flow Mass Flow Controllers

0 to 250SLPM Full Scale through 0 to 2000SLPM Full Scale

The following specifications are for the standard configuration of the Alicat product. There are many low-cost customization options available.

Specification	Mass Controller	Description
Accuracy	± (0.8% of Reading + 0.2% of Full Scale)	At calibration conditions after tare
High Accuracy Option ¹	± (0.4% of Reading + 0.2% of Full Scale)	At calibration conditions after tare
Repeatability	± 0.2%	Full Scale
Operating Range	1% to 100% Full Scale	Measure and Control
Typical Response Time	100	Milliseconds (Adjustable)
Standard Conditions (STP)	25°C & 14.696PSIA	Mass Reference Conditions
Operating Temperature	-10 to +50	°Celsius
Zero Shift	0.02%	Full Scale / °Celsius / Atm
Span Shift	0.02%	Full Scale / °Celsius / Atm
Humidity Range	0 to 100%	Non-Condensing
Controllable Flow Rate	102.4%	Full Scale
Maximum Pressure	145	PSIG
Input /Output Signal Digital	Mass Flow, Volumetric Flow, Pressure & Temperature	RS-232 Serial or PROFIBUS ²
Input / Output Signal Analog	Mass Flow	0-5Vdc
Optional Input / Output Signal Secondary Analog	Mass Flow, Volumetric Flow, Pressure or Temperature	0-5 Vdc or 0-10Vdc or 4-20mA
Electrical Connections	8 Pin Mini-DIN or DB-15	
Supply Voltage	24 to 30 Vdc	
Supply Current	0.750Amp	
Mounting Attitude Sensitivity	Control response somewhat sensitive to inverted operation.	
Warm-up Time	< 1	Second
Wetted Materials ³	303 & 302 Stainless Steel, Viton®, Silicone RTV (Rubber), Glass Reinforced Nylon, Aluminum, 410 & 416 Stainless Steel, Nickel, Silicon, Glass.	

1. High Accuracy option not available for 2000SLPM units.
 2. If selecting PROFIBUS no analog signal is available. PROFIBUS units do not have the display. See page 41 PROFIBUS specifications for PROFIBUS supply voltages and currents.
 3. If your application demands a different material, please contact Application Assistance for available options.

Mechanical Specifications

Full Scale Flow Mass Controller	Mechanical Dimensions	Process Connections ¹	Pressure Drop ² (PSID)
250SLPM	5.5”H x 7.9”W x 2.3”D	1/2” NPT Female	4.6
500SLPM	5.5”H x 7.4”W x 2.3”D	3/4” NPT Female	6.5
1000SLPM			14.0
1500SLPM			17.0
2000SLPM			30.0

1. Compatible with Beswick®, Swagelok® tube, Parker®, face seal, push connect and compression adapter fittings.
 2. Venting to atmosphere. Lower Pressure Drops Available, Please contact Application Assistance.

Dimensional Drawings: page 39

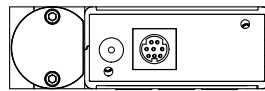

MC Series:

- 0 - 0.5SCCM
- 0 - 1SCCM
- 0 - 2SCCM
- 0 - 5SCCM
- 0 - 10SCCM
- 0 - 20SCCM
- 0 - 50SCCM

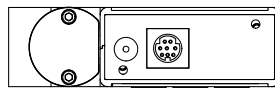
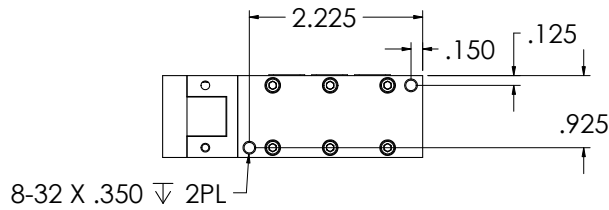
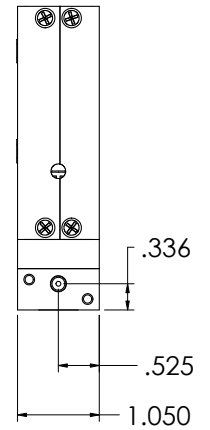
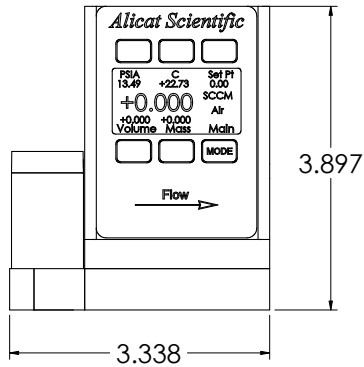
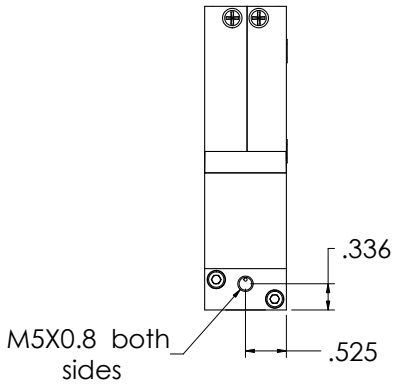

MC Series:

- 0 - 100SCCM
- 0 - 200SCCM
- 0 - 500SCCM
- 0 - 1SLPM
- 0 - 2SLPM
- 0 - 3SLPM
- 0 - 5SLPM
- 0 - 10SLPM
- 0 - 20SLPM

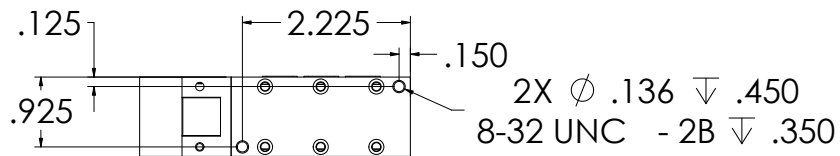
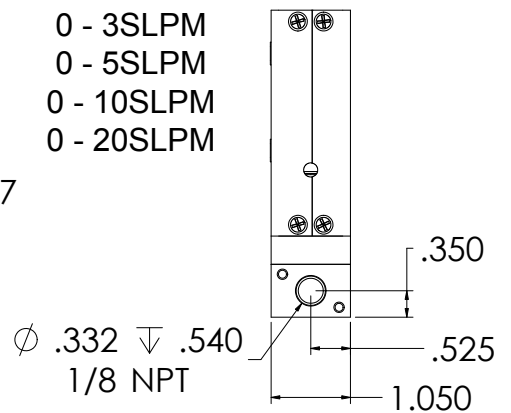
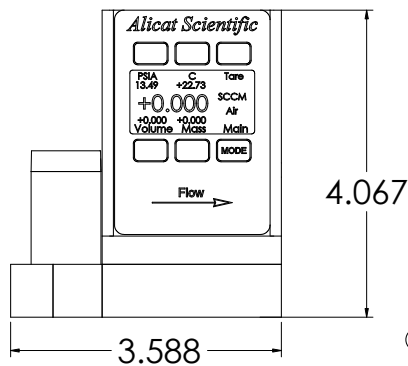
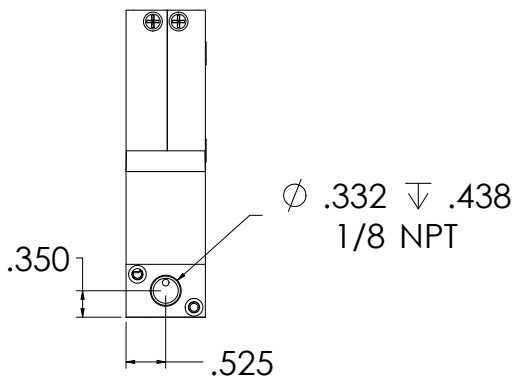

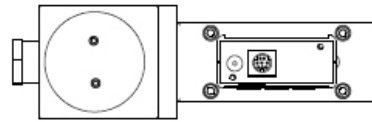

MC Series:
 0 - 50SLPM
 0 - 100SLPM

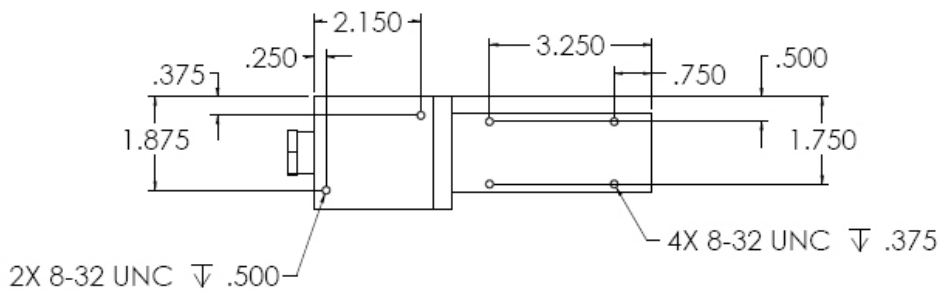
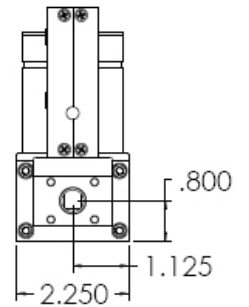
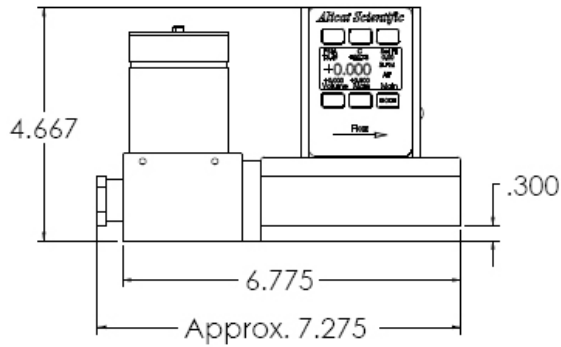
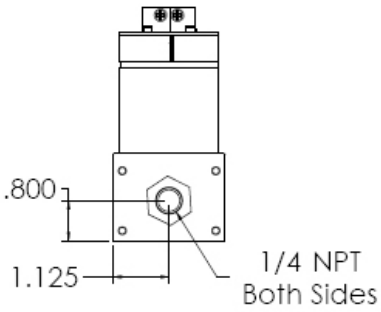

MCR Series:
 0 - 250SLPM

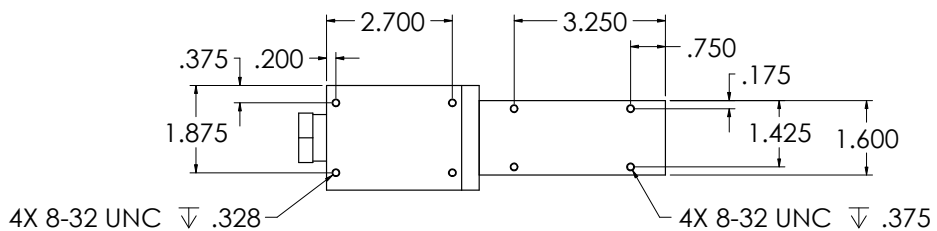
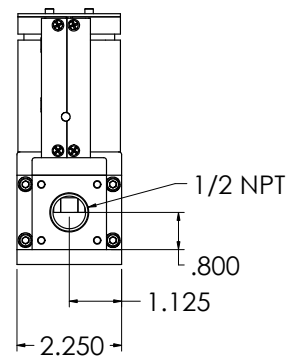
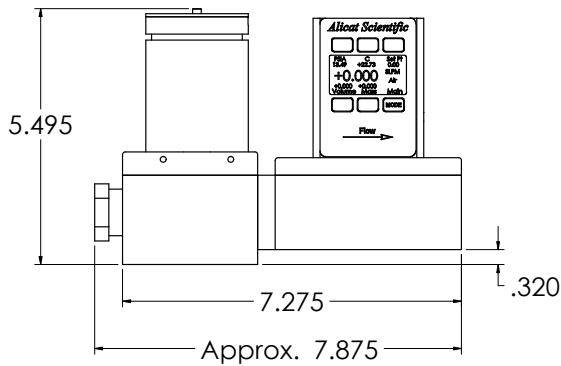
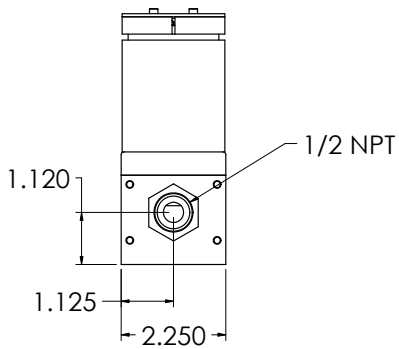
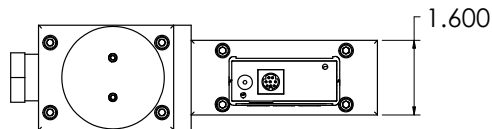

MCR Series:
 0 - 500SLPM
 0 - 1000SLPM
 0 - 1500SLPM

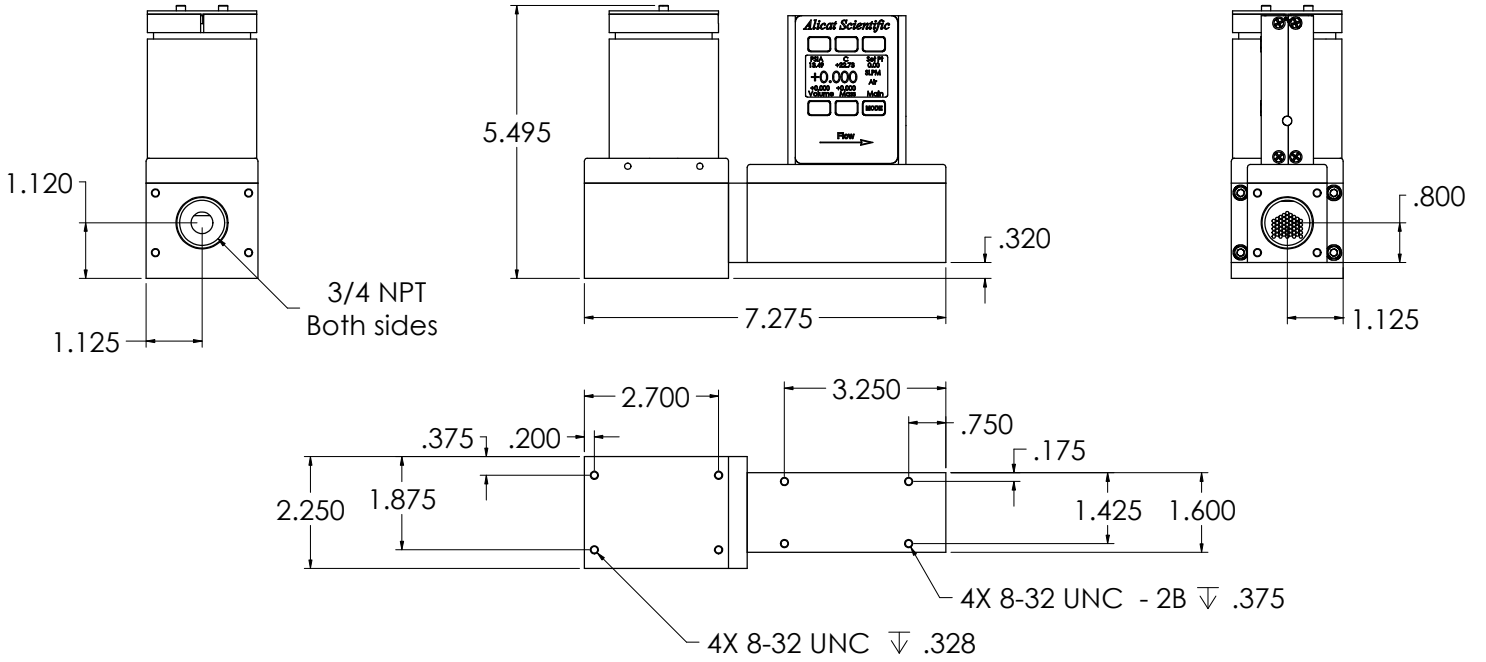
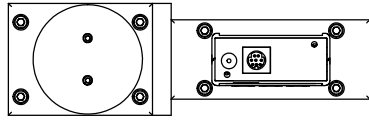

MCR Series:
 0 - 2000SLPM

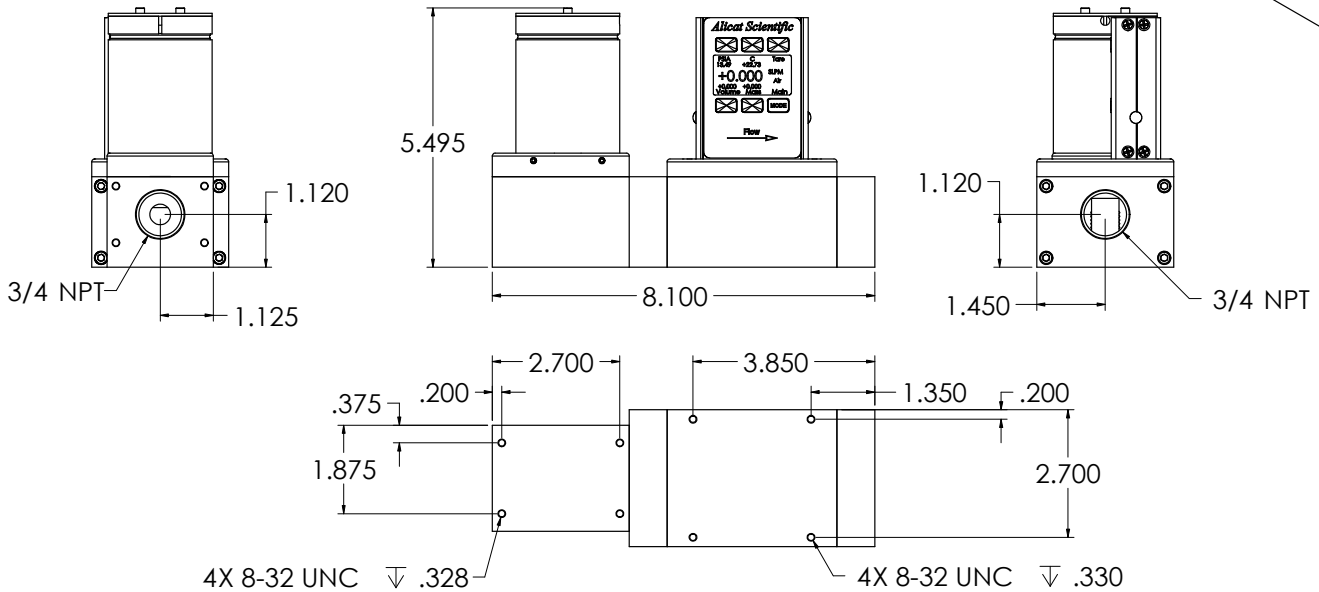
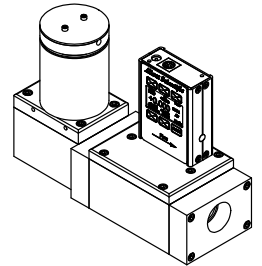
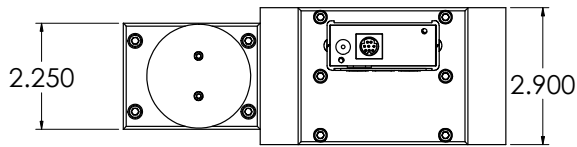

Technical Data for MCV Mass Flow Controller for Vacuum Applications

0 to 0.5SCCM Full Scale through 0 to 20SLPM Full Scale

Specification	MCV Mass Controller	Description
Accuracy	± (0.8% of Reading + 0.2% of Full Scale)	At calibration conditions after tare
High Accuracy Option ¹	± (0.4% of Reading + 0.2% of Full Scale)	At calibration conditions after tare
Repeatability	± 0.2%	Full Scale
Operating Range	1% to 100% Full Scale	Measure and Control
Typical Response Time	100	Milliseconds (Adjustable)
Standard Conditions (STP)	25°C & 14.696PSIA	Mass Reference Conditions
Operating Temperature	-10 to +50	°Celsius
Zero Shift	0.02%	Full Scale / °Celsius / Atm
Span Shift	0.02%	Full Scale / °Celsius / Atm
Humidity Range	0 to 100%	Non-Condensing
Controllable Flow Rate	102.4%	Full Scale
Maximum Pressure	145	PSIG
Input /Output Signal Digital	Mass Flow, Volumetric Flow, Pressure & Temperature	RS-232 Serial or PROFIBUS ²
Input / Output Signal Analog	Mass Flow	0-5Vdc
Optional Input / Output Signal Secondary Analog	Mass Flow, Volumetric Flow, Pressure or Temperature	0-5 Vdc or 0-10Vdc or 4-20mA
Electrical Connections	8 Pin Mini-DIN or DB-15	
Supply Voltage	12 to 30 Vdc (15-30Vdc for 4-20mA outputs)	
Supply Current	0.300Amp	
Mounting Attitude Sensitivity	None	
Warm-up Time	< 1	Second
Integrated Valve Leak Integrity	1 x 10 ⁻⁹ atm sccm/sec Helium max	
Wetted Materials ³	316L,303 & 302 Stainless Steel, Viton®, Silicone RTV (Rubber), Glass Reinforced Nylon, Aluminum, Brass, 410 Stainless Steel, Silicon, Glass, PCTFE.	

1. High Accuracy Option not available for ranges below 5SCCM.
2. If selecting PROFIBUS no analog signal is available. PROFIBUS units do not have the display. See page 41 for PROFIBUS specifications for PROFIBUS supply voltages and currents.
3. If your application demands a different material, please contact Application Assistance for available options.

Mechanical Specifications

Full Scale Flow MCV Controller	Mechanical Dimensions	Process Connections
0.5SCCM to 20SLPM	4.992"H x 6.710"W x 1.50"D	1/4" VCR Male

MCV Series

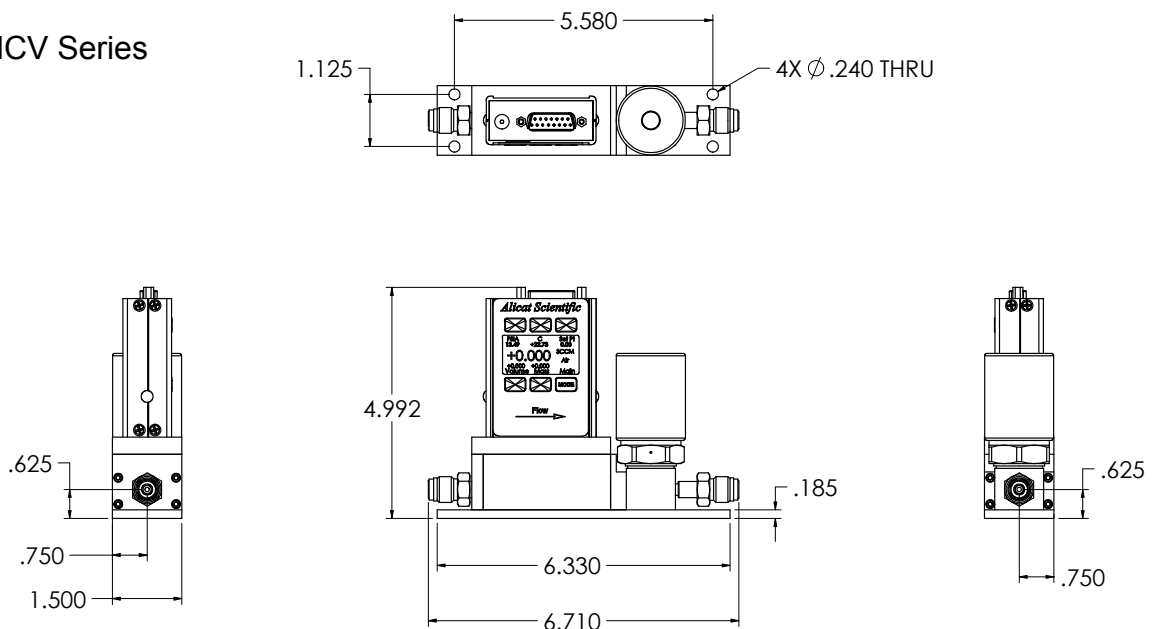

Technical Data for PROFIBUS Mass Flow Meters and Controllers

NOTICE: The following specifications are applicable to Aicat PROFIBUS enabled mass meters and mass controllers only.

All standard device features and functions are available and operate in accordance with the standard Aicat Scientific device operating manual provided with the device.

Specification	Mass Meter	Mass Controller	Description
Accuracy	± (0.8% of Reading + 0.2% of Full Scale)		At calibration conditions after tare
High Accuracy Option	± (0.4% of Reading + 0.2% of Full Scale)		At calibration conditions after tare
Repeatability	± 0.2%		Full Scale
Operating Range	1% to 100% Full Scale		Measure and Control
Typical Response Time	10	100	Milliseconds (Adjustable)
Standard Conditions (STP)	25°C & 14.696PSIA		Mass Reference Conditions
Operating Temperature	-10 to +60		°Celsius
Zero Shift	0.02%		Full Scale / °Celsius / Atm
Span Shift	0.02%		Full Scale / °Celsius / Atm
Humidity Range	0 to 100%		Non-Condensing
Measurable Flow rate	128%		Full Scale
Controllable Flow Rate		102.4%	Full Scale
Maximum Pressure	145		PSIG
Input /Output Signal Digital	Mass, Volumetric, Pressure & Temperature		RS-232 Serial, PROFIBUS DP
Electrical Connections	DB9		
Supply Voltage:			
Meters	7 to 30 Vdc		
Small Valve Controllers		12 to 30 Vdc	
Large Valve Controllers		24 to 30 Vdc	
Supply Current	80mA @ 12Vdc 65mA @ 24Vdc	295mA @ 12Vdc 280mA @ 24Vdc	
Mounting Attitude Sensitivity	None		
Warm-up Time	< 1		Second
Wetted Materials ²	303 & 302 Stainless Steel, Viton®, Silicone RTV (Rubber), Glass Reinforced Nylon, Aluminum, Brass, 410 & 416 Stainless Steel.		
1. If your application demands a different material, please contact Application Assistance for available options.			

Power and Signal Connections:

Connect to the device using two DB9 connectors.

The female top connection is PROFIBUS.

The male connection on the side is power and RS-232.

Pin out diagrams for all PROFIBUS enabled Aicat devices are shown:

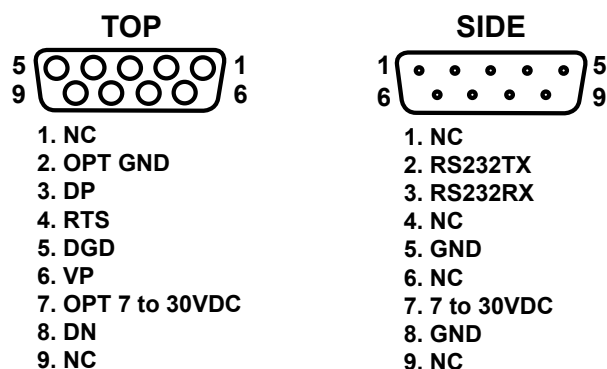

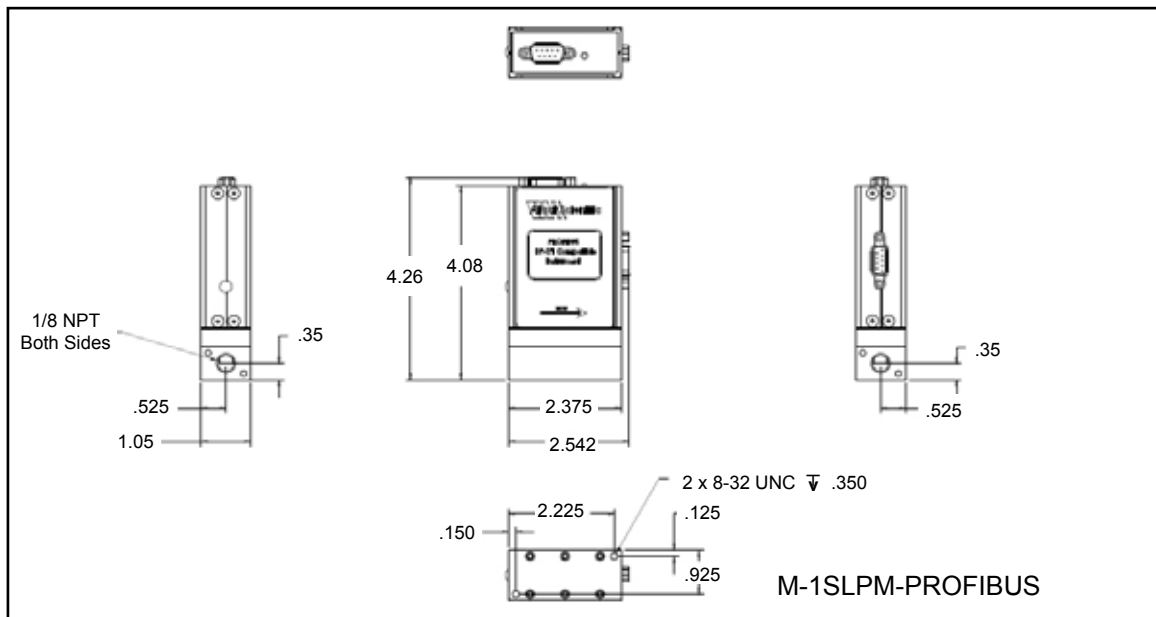
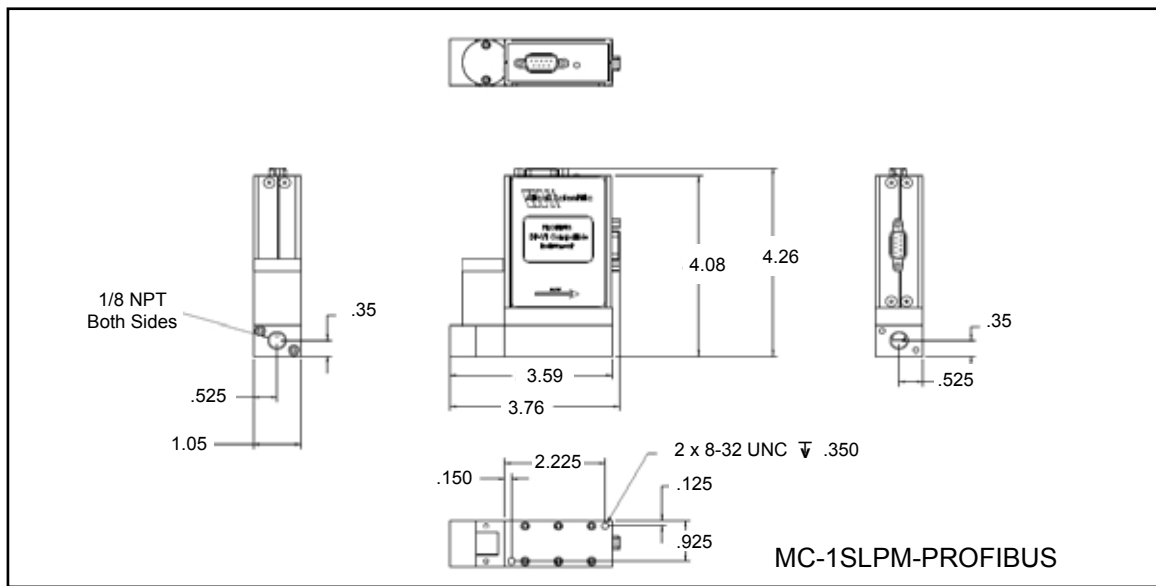
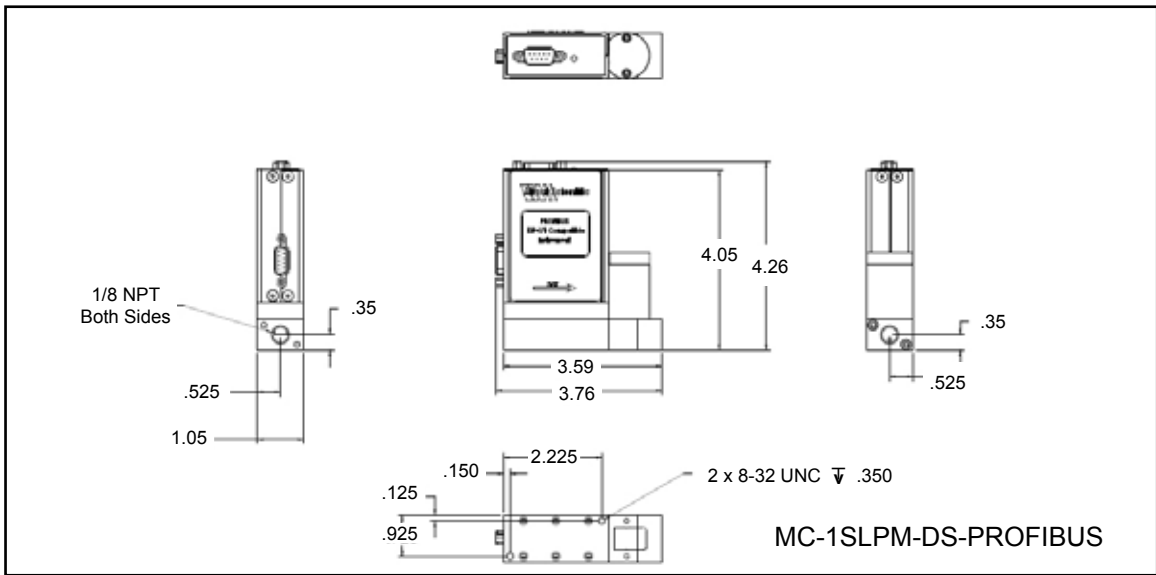

Flow body dimensions will vary with range. Please see Alicat's device specifications for flow body dimensions.

Option: Totalizing Mode

16 Series Flow Meters and Controllers can be purchased with the Totalizing Mode option. This option adds an additional mode screen that displays the total flow (normally in the units of the main flow screen) that has passed through the meter or controller since the last time the totalizer was cleared. The Totalizing Mode screen shown below is accessed by pushing the “MODE” button until the label over it reads “Total”. *If your meter or controller is ordered with Totalizing Mode option, pushing the “Mode” button once will bring up the “Totalizing Mode” display. Pushing “Mode” a second time will bring up the “Select Menu” display. Pushing it a third time will return you to the Main Mode Screen.*

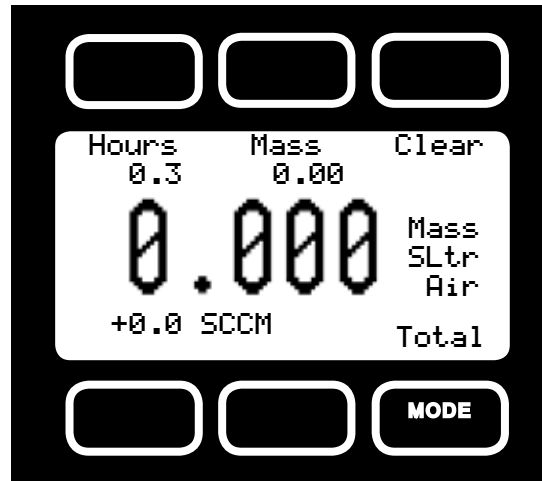

Counter – The counter can have as many as six digits. At the time of order, the customer must specify the resolution of the count. This directly affects the maximum count. For instance, if a resolution of 1/100ths of a liter is specified on a meter which is totalizing in liters, the maximum count would be 9999.99 liters. If the same unit were specified with a 1 liter resolution, the maximum count would be 999999 liters.

Rollover – The customer can also specify at the time of order what the totalizer is to do when the maximum count is reached. The following options may be specified:

No Rollover – When the counter reaches the maximum count it stops counting until the counter is cleared.

Rollover – When the counter reaches the maximum count it automatically rolls over to zero and continues counting until the counter is cleared.

Rollover with Notification – When the counter reaches the maximum count it automatically rolls over to zero, displays an overflow error, and continues counting until the counter is cleared.

Hours – The display will show elapsed time since the last reset in 0.1 hour increments. The maximum measurable elapsed time is 6553.5 hours (about nine months). The hours count resets when the “clear” button is pushed, an RS-232 clear is executed or on loss of power

Clear – The counter can be reset to zero at any time by pushing the dynamically labeled “Clear” button located above the upper right corner of the display. To clear the counter via RS-232, establish serial communication with the meter or controller as described in the RS-232 section of the manual. To reset the counter, enter the following commands:

In Streaming Mode: `$$T <Enter>`

In Polling (addressable) Mode: `Address$$T <Enter>` (e.g. `B$$T <Enter>`)

Alicat Portable Meters and Gauges

Alicat Portable Flow Meters and Gauges use a common 9 Volt battery located in the top section of your meter.

Output signals from the flow meter are passed through the female connector on top of the flow meter. Turn the switch on top of the flow meter “off” when the meter is not in use.

Normal (9V alkaline) battery life is approximately 8 hours (30-40 hours with a 9V-lithium battery), however many factors can affect this.

Replace the battery as often as required. A yellow LED indicates low voltage and that the battery should be replaced.

A false signal can result when the voltage drops below its normally regulated level.

Alicat Portable Flow Meters and Gauges can also be powered by an optional AC/DC plug-in wall adaptor. With the adaptor plugged into the flow meter, the battery is bypassed and the meter will operate solely off the adaptor power supply.

Replacing the Battery:

1. Remove the four Phillips head screws from the front cover and gently remove it as shown below.
2. Remove the 9V battery, pulling the top of the battery out first.
3. Disconnect the old battery from the harness and replace it with a new battery.
4. Install the new battery bottom end first and replace the back cover so that the cushioning pad presses directly down on the battery.
5. Replace the four Phillips head screws.

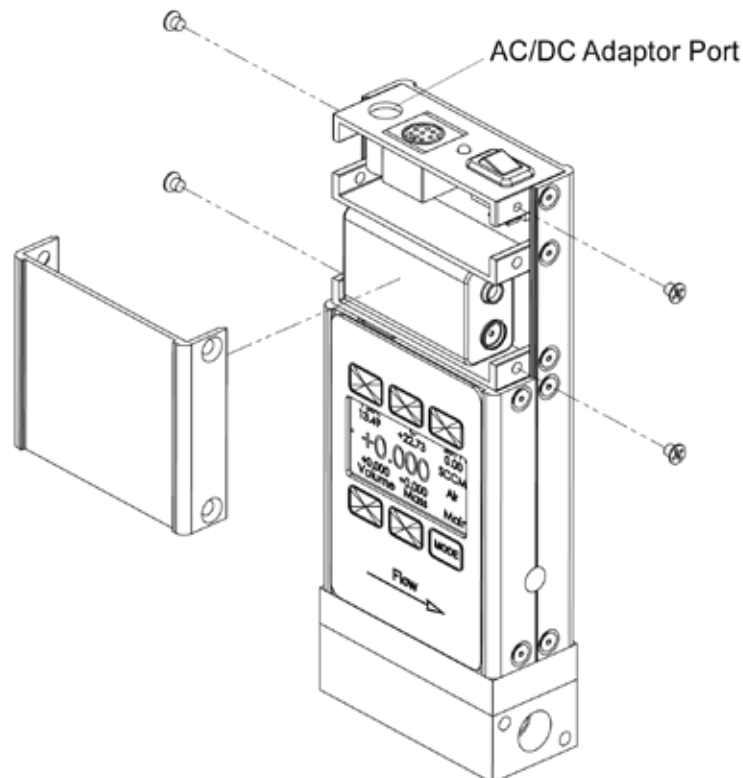

Battery cover removal

Option: Remote Electronics for High Line or Gas Temperatures

Some applications involve operating temperatures outside the standard Alicat device specifications. A solution using remote electronics is available. (This option is not applicable to liquid devices.)

The flow body's components are minimized to only the required sensors. The flow data is sent to the microprocessor electronics up to 6 feet away from the sensor package. Relocating the sensitive electronics, including the LCD, allows for installation of the flow body in ambient temperatures as high as 85° Celsius with gas temperatures under 100° Celsius.

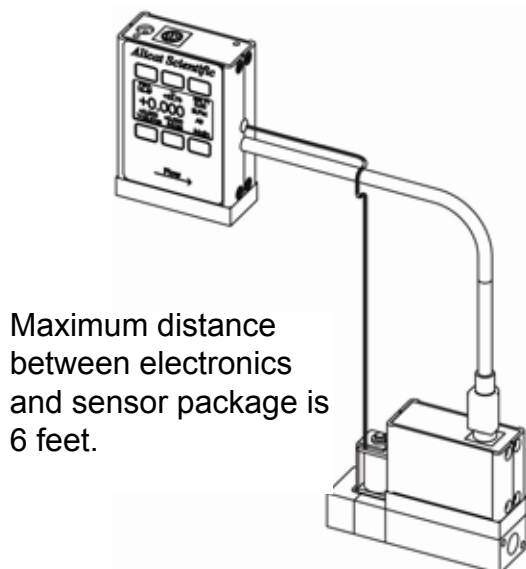

In these applications we recommend our custom gauge calibration at a gas temperature of up to 70° Celsius. This will reduce zero shift errors that occur when actual gas flow temperatures deviate substantially from the gas calibration temperature. This configuration is also used in integrations that require a compact flow package at the installation point.

Accessory: BB-9 Multi-Drop Box



The **BB-9 Multi-Drop Box** makes it convenient to wire multiple flow and/or pressure devices to a single RS-232 port.

The Multi-Drop Box has nine 8 pin mini-DIN ports available. The ports are to be used with a standard double ended 8 pin mini-DIN (DC-62) style cable going from the box to each flow or pressure device. A single DB9 D-SUB type connector (COM PORT) connects, using the included cable, to the serial connector on a PC or laptop.

All of the flow and/or pressure devices are powered via a terminal block on the front of the box.

If more than nine devices will be required, additional Multi-Drop Boxes can be daisy chained together with a double ended 8 pin mini-DIN cable plugged into any receptacle on both boxes.

Accessory: RS-232 to RS-485 Converter

Since most computers have RS-232 communication onboard, Alicat has chosen RS-232 as the digital standard on all of its flow instruments. For those using RS-485 as their primary standard, our **RS-232 to RS-485** converter will allow interface between an RS-485 system and Alicat's flow instrumentation.

Accessory: Flow Vision™ SC Software

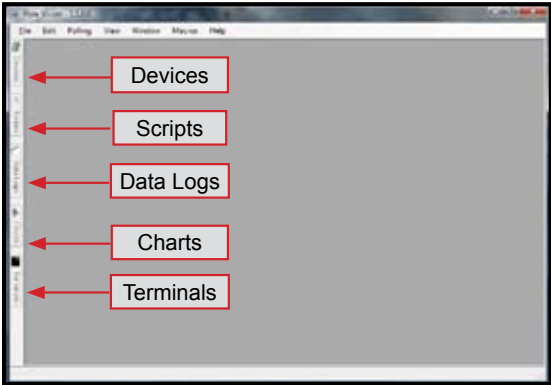

Flow Vision™ SC is an intuitive software interface to help your test cycles run smoother and shorten your engineering time!

Flow Vision™ SC lets you connect to and communicate with multiple Alicat units simultaneously. Now you can view virtual displays, control tabs, charts and data lines from every connected Alicat device on the same screen.

Flow Vision™ SC supports all RS-232 Serial communication functions, including: **gas selection, taring, set-point control, valve tuning and flow averaging.**

Session Saving: Save and reload your configuration data with confidence.

Script Building: Create scripts to adjust a controller's set-point value at variable specified time intervals.

Charting: Chart as many parameters as you want off as many devices as you want, with color coding, zooming, and printing functionality.

Alarms: Create software alarms that will notify you of given parameter conditions.

Data Capture & Logging: Capture and log data to either a .csv file or a .txt file. Improved Data Logging and Data Log File Splitting for easy to manage data.

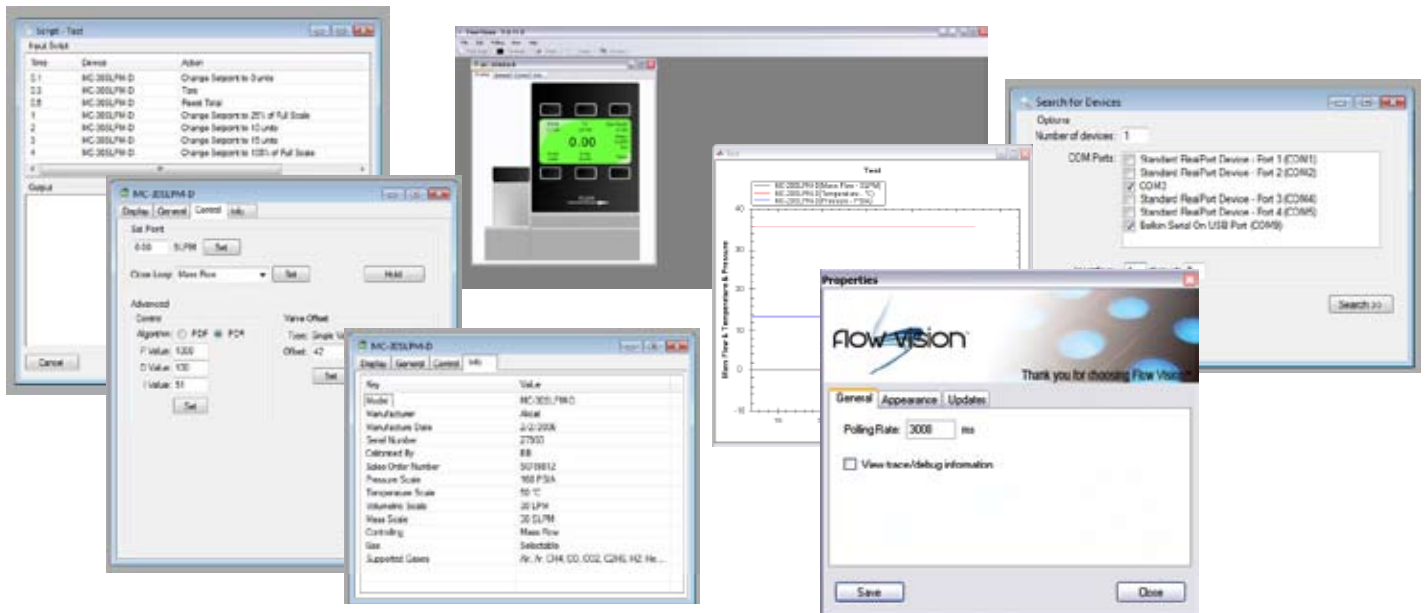

Flow Vision™ SC supports multiple devices connected to the same RS-232 port.

Simply connect each device to a **BB-9 Multi-Drop Box**, then using device addressability, assign an identifier to each instrument.

Now you can easily monitor and control multiple Alicat instruments from your computer.



Accessories

Part Number	Description
FLOWVISIONSC	Flow Vision™ SC software for interface with all Alicat instruments
BB-9	Multi-Drop Box
PCASE	Industrial carry and storage case for portable meters/gauges
DC-61	8 Pin Male Mini-DIN connector cable, single ended, 6 foot length
DC-251	8 Pin Male Mini-DIN connector cable, single ended, 25 foot length
DC-301	8 Pin Male Mini-DIN connector cable, single ended, 30 foot length
DC-501	8 Pin Male Mini-DIN connector cable, single ended, 50 foot length
DC-751	8 Pin Male Mini-DIN connector cable, single ended, 70 foot length
DC-6RT	8 Pin Male <i>Right Angle</i> Mini-Din Cable, single ended, 6 foot length
DC-62	8 Pin Male Mini-DIN connector cable, double ended, 6 foot length
DC-252	8 Pin Male Mini-DIN connector cable, double ended, 25 foot length
DC-502	8 Pin Male Mini-DIN connector cable, double ended, 50 foot length
DC-602	8 Pin Male Mini-DIN connector cable, double ended, 60 foot length
MD8DB9	8 Pin Male Mini-DIN to DB9 Female Adapter, 6 foot length
IC10	Industrial cable, 6 Pin, single ended, 10 foot length
IC10-18G	18 gauge industrial cable, 6 Pin, single ended, 10 foot length
IC20	Industrial cable, 6 Pin, single ended, 20 foot length
IC24-18G	18 gauge industrial cable, 6 Pin, single ended, 24 foot length
IC50	Industrial cable, 6 Pin, single ended, 50 foot length
PVPS24U	Universal 100-240 VAC to 24 Volt DC Power Supply Adapter
LSPM	Local Set-Point Module
RS485-KIT	RS-232 to RS-485 Converter
REMOTE	Remote electronics with display
RD	Remote Panel Mount Display

	ALICAT DEVICE PROCESS CONNECTION				
	M5 (10-32)	1/8"	1/4"	1/2"	3/4"
COMPRESSION FITTING					
1/8"	SS-200-1-0157	SS-200-1-2	SS-200-1-4	SS-200-1-8	
1/4"	SS-400-1-0256	SS-400-1-2	SS-400-1-4	SS-400-1-8	SS-400-1-12
1/2"		SS-810-1-2	SS-810-1-4	SS-810-1-8	SS-810-1-12
3/4"				SS-1210-1-8	SS-1210-1-12
3mm		SS-3M0-1-2	SS-3M0-1-4		
4mm		SS-4M0-1-2	SS-4M0-1-4		
6mm		SS-6M0-1-2	SS-6M0-1-4	SS-6M0-1-8	
8mm		SS-8M0-1-2	SS-8M0-1-4	SS-8M0-1-8	
12mm		SS-12M0-1-2	SS-12M0-1-4	SS-12M0-1-8	SS-12M0-1-12
16mm				SS-16M0-1-8	SS-16M0-1-12
FILTER					
10 micron		2F-F2L-10-B			
20 micron	CF-303-20-316				
50 micron		2F-F2L-50-B	4F-F4L-50-B	8F-F8L-50-B	12F-F12L-50-B
ADAPTER	410133	Male M5 (10-32) Buna-N O-ring face seal to 1/8"Female NPT			



DB15 Pin-Outs

If your Alicat Instrument was ordered with a DB15 connection, please be sure to reference the appropriate pin-out diagram.

DB15 Pin-Out

Pin Number	Function
2	Signal Out
5	Supply
8	Set-Point
9	Ground
11	Secondary Out
13	RS-232 Receive
15	RS-232 Send

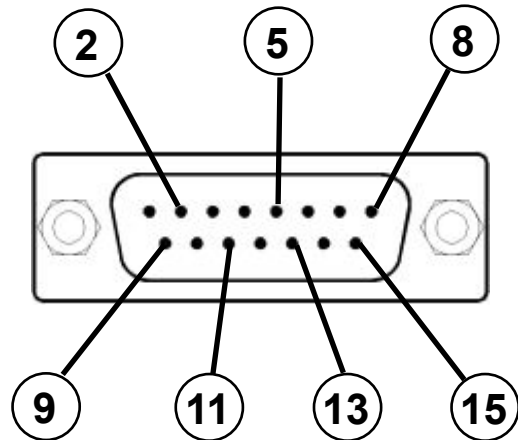

Note: The above pin-out is correct for units with a **DB15** pin-out. If your unit is marked **DB15H** or **DB15K**, you must use the correct pin-out (as shown on the following page).



DB15 Pin-Outs

If your Alicat Instrument was ordered with a DB15 connection, please be sure to reference the appropriate pin-out diagram.

DB15H Pin-Out

Pin Number	Function
6	Signal Out
7	Ground
11	Supply
14	Set-Point
10	Secondary Out
2	RS-232 Receive
15	RS-232 Send

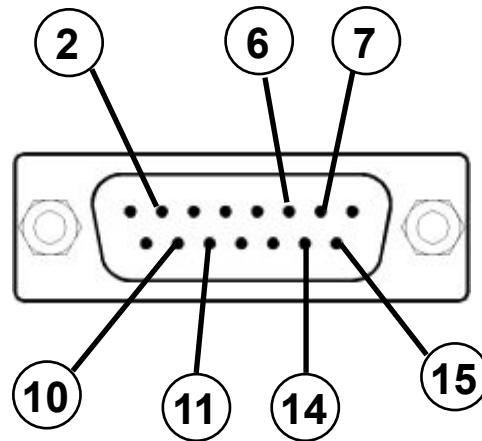

DB15K Pin-Out

Pin Number	Function
2	Signal Out
5	Ground
7	Supply
8	Set-Point
9	Secondary Out
13	RS-232 Receive
14	RS-232 Send

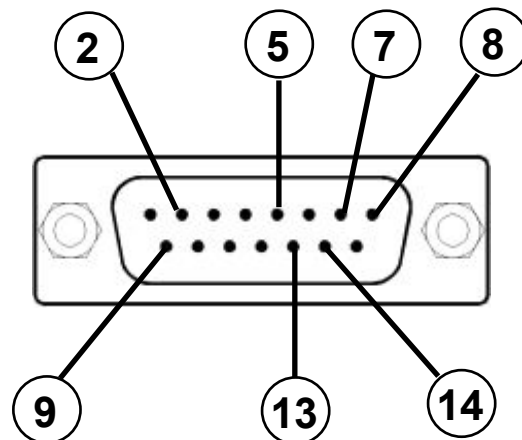

Note: The above pin-outs are correct for units with a **DB15H** or **DB15K** pin-out. If your unit is marked **DB15**, you must use the correct pin-out (see the previous page).