

**ISOPAQ-40P**

**High-performance Isolation Transmitter for Unipolar mA/V Signals with Calibrated Range Selection**



The Isolation Transmitter IsoPAQ-40P is used for high-precision isolation and conversion of 0-20 mA, 4-20 mA and 0-10 V unipolar signals.

Due to the calibrated range selection of the input/output signals, the selectable bandwidth and the universal power supply, IsoPAQ-40P provides excellent flexibility and low storage and installation costs.

The high reliability and the Protective Separation are additional features that ensure a safe system operation.

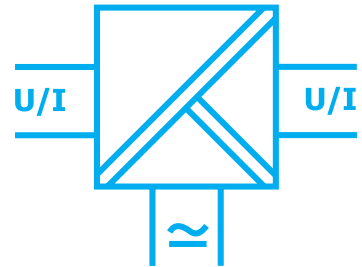

- **Calibrated range selection**  
Input and output range in mA or V can be set by using DIP switches without any further adjustments
- **Protective Separation**  
The design and high isolation level (4 kV) provides protection for service personnel and downstream devices against impermissibly high voltage
- **High accuracy**  
Negligible additional measurement errors in the loop
- **Universal power supply for 20 to 253 VAC/DC**  
Applicable world-wide for all common supply voltages

- **3-port isolation**  
Protection against erroneous measurements due to parasitic voltages or ground loops
- **High-density DIN-rail mounting**  
12.5 mm (0.5") housing combined with very low self heating allows for high density mounting
- **Plug-in screw terminals**  
Simplifies installation and maintenance
- **Excellent reliability**  
Low self heating thanks to patented high-efficiency power supply provides long-term reliability and stability

## Specifications: IsoPAQ-40P

### Input

Input signal	<b>0-20 mA<sup>1)</sup></b>	4-20 mA	0-10 V	Terminal/switch selectable
Input resistance	Current input		22 Ω	
	Voltage input		1 MΩ	
Input capacitance	Approx. 1 nF			
Overload	Current input		≤200 mA	
	Voltage input		Voltage limitation via 30 V Z-Diode, max.continuous current 30 mA	

### Output

Output signal	<b>0-20 mA<sup>1)</sup></b>	4-20 mA	0-10 V	Switch selectable
Load	Current output		≤600 Ω	
	Voltage output		> 1_kΩ	
Linear transmission range	-2 to +110 %			
Ripple	< 0.1 % of end value, ~150 kHz			

### General data

Transmission error	± 0.1 % of end value			
Temperature coefficient <sup>2)</sup>	± 0.005 %/K of end value			
Cut-off frequency (-3 dB)	<b>&gt; 1 kHz<sup>1)</sup></b>		Switchable to < 30 Hz	
Test voltage	4 kV, 50 Hz		Input against output against power supply	
Working voltage <sup>3)</sup> (Basic Insulation)	600 VAC/DC for overvoltage category II and contamination class 2 acc. to EN 61010 part 1			
Protection against dangerous body currents <sup>3)</sup>	300 VAC/DC for overvoltage category II and contamination class 2 between all circuits.			
Ambient temperature	Operation		-20 to +70 °C (-4 to +158 °F)	
	Transport and storage		-35 to +85 °C (-31 to +185 °F)	
Power supply	20 to 253 VAC/DC		AC 48 to 62 Hz, approx. 2 VA	
			DC approx. 1 W	
EMC <sup>4)</sup>	EN 61326-1			
Construction	12.5 mm (0.5") housing, protection type: IP 20			
Connection	≤2.5 mm <sup>2</sup> , AWG 14			
Weight	Approx. 100 g			

#### 1) Factory setting

- 2) Average TC in specified operating temperature range
- 3) As far as relevant the standards and rules mentioned above are considered by development and production of our devices. In addition relevant assembly rules are to be considered by installation of our devices in other equipments. For applications with high working voltages, take measures to prevent accidental contact and make sure that there is sufficient distance or insulation between adjacent situated devices.
- 4) Minor deviations possible during interference

### Dimensions

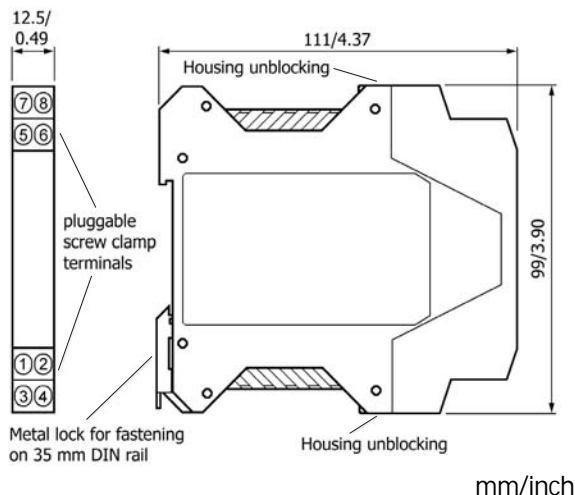

### Block diagram/Connections

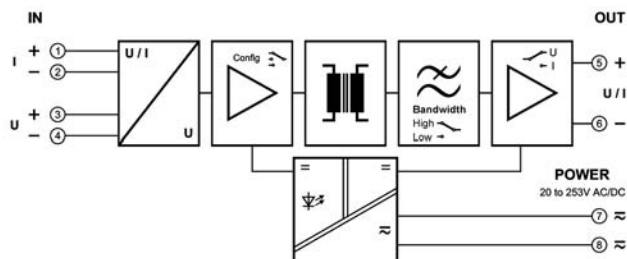

### Ordering information

Product	Input / Output	Part No.
IsoPAQ-40P	Calibrated range selection	70ISP40001