

## M-CONTROLLER & M-RELAY MONITOR AND CONTROL SYSTEM

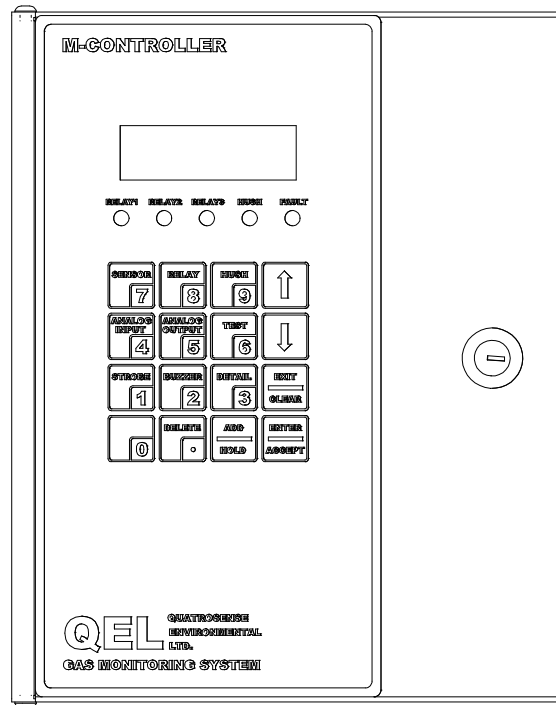

## INSTALLATION OPERATION AND MAINTENANCE MANUAL

QUATROSENSE ENVIRONMENTAL LTD.  
5935 OTTAWA STREET, PO BOX 749 RICHMOND, ONTARIO CANADA K0A 2Z0  
PHONE: (613) 838-4005 FAX: (613) 838-4018  
Web: [www.QELsafety.com](http://www.QELsafety.com) Email: [QEL@QELsafety.com](mailto:QEL@QELsafety.com)

<b>1</b>	<b>GLOSSARY.....</b>	<b>4</b>
<b>2</b>	<b>GENERAL SYSTEM OVERVIEW.....</b>	<b>5</b>
<b>3</b>	<b>M- CONTROLLER SPECIFICATIONS.....</b>	<b>6</b>
<b>4</b>	<b>M-CONTROLLER ANALOG OUTPUT OPTION CARD .....</b>	<b>8</b>
4.1	SPECIFICATIONS.....	8
4.2	COMMON RETURN LINE.....	8
4.3	ISOLATING THE SIGNALS.....	8
<b>5</b>	<b>M-RELAY-5 AMP SPECIFICATIONS.....</b>	<b>9</b>
<b>6</b>	<b>M-CONTROLLER FUNCTIONS .....</b>	<b>10</b>
6.1	SYSTEM SETUP.....	10
6.1.1	<i>Miscellaneous</i> .....	10
6.1.2	<i>Calibrations</i> .....	10
6.2	RELAY CONFIGURATIONS .....	10
6.2.1	<i>Common Functions</i> .....	10
6.2.2	<i>Voting</i> .....	11
6.2.3	<i>Averaging</i> .....	11
6.2.4	<i>Sensor Configuration</i> .....	12
6.3	ANALOG INPUT CONFIGURATION.....	12
<b>7</b>	<b>SENSORS AND ADDRESSING .....</b>	<b>13</b>
<b>8</b>	<b>ANALOG INPUTS AND ADDRESSING .....</b>	<b>13</b>
<b>9</b>	<b>M-RELAY FUNCTIONS AND ADDRESSING.....</b>	<b>14</b>
<b>10</b>	<b>KEYPAD OPERATION AND CONFIGURING THE DATABASES.....</b>	<b>15</b>
10.1	STATUS VIEW AND ACKNOWLEDGE COMMANDS.....	16
<b>11</b>	<b>DATABASE CONFIGURATION MENU TREE.....</b>	<b>20</b>
11.1	EXPLANATION OF DISPLAY .....	21
11.2	CHANGE PASSWORD .....	21
11.3	ACQUIRE COMPUTER .....	21
11.4	CALIBRATION DISABLE.....	22
11.5	TESTING (FORCE OUTPUTS).....	22
11.6	HOW TO CREATE DATABASE .....	23
11.7	MODIFY SENSOR DATABASE.....	24
11.8	MODIFY ANALOG INPUT DATABASE.....	25
11.9	MODIFY RELAY DATABASE .....	25
11.10	MODIFY RELAY SENSOR ASSIGNMENTS .....	26
11.11	MODIFY RELAY STYLES.....	27

11.12	MODIFY BUZZER DATABASE .....	28
11.13	MODIFY STROBE DATABASE.....	28
11.14	MODIFY ANALOG OUTPUT DATABASE .....	28
11.15	SYSTEM SETTINGS .....	30
11.15.1	<i>Operating Configuration</i> .....	30
11.15.2	<i>Calibration</i> .....	30
<b>12</b>	<b>COMPUTER INTERFACE: PROGRAMMING AND AUDITING.....</b>	<b>32</b>
12.1	M-VIEW.....	32
12.2	IF YOUR COMPUTER INSTALLED PREVIOUS VERSION M-VIEW, THE SETUP PROGRAM WILL REMOVE IT FIRST, THEN RUN SETUP.EXE AGAIN TO INSTALL THE LATEST VERSION M-VIEW. M-CONTROLLER SETUP.....	33
12.2	M-CONTROLLER SETUP .....	34
<b>13</b>	<b>MODBUS PROTOCOL SUPPORTED BY M-CONTROLLER.....</b>	<b>35</b>
13.1	SERIAL TRANSMISSION MODE .....	35
13.2	FUNCTION CODE SUPPORTED BY M-CONTROLLER .....	35
<b>14</b>	<b>POWER SUPPLY AND WIRING .....</b>	<b>40</b>
14.1	POWER REQUIREMENTS .....	40
14.2	TRANSFORMERS.....	41
14.3	STROBE AND HORN.....	41
14.4	ANALOG OUTPUT ISOLATION.....	42
14.5	ANALOG INPUT NOT ISOLATED.....	42
14.6	GROUNDING.....	43
14.7	RS-485 INSTALLATION .....	43
14.8	RS-422 INSTALLATION .....	44
<b>15</b>	<b>TROUBLESHOOTING HINTS.....</b>	<b>45</b>
	<b>WARRANTY STATEMENT .....</b>	<b>46</b>

# 1 Glossary

**Actuate/De-Actuate:** These terms are used instead of ‘make’ and ‘break’ to allow us to distinguish between performing an action due to an environmental condition and whether the contact may be closed (‘made’) or open (‘break’) because of our use of double throw contacts, and the option of normally energized relays.

**Averaging:** When setting alarms, the alarm can be set to operate on the basis of the average signal assigned to that relay. It must be the same gas range.

**Baud rate:** A measure of the speed at which data is transferred over a digital communication link. Given as bit per second (bps). Generally the lower the speed, the more reliable.

**bps:** See Baud rate

**Characteristic Impedance:** The effects of capacitance and inductance of a pair of wires expressed as an equivalent resistance.

**Configuration Database:** System configuration requires entering a great deal of information concerning relay operation, sensor type and so on.

**Download:** Send data files ‘down’ to a slave device as from a computer to the M-Controller.

**Dry Contacts:** The relay contacts are supplied without power applied to any output terminal.

**Normally Energized:** The relay coil is energized in the non-alarm state. This is sometimes referred to as ‘fail-safe’ because in the case of controller failure or loss of power, the relay contacts will open.

**Normally Open Contacts:** In the non-alarm state, but under power, the contacts are open.

**Latching:** A relay once actuated remains actuated even though the condition has been removed. Requires a manual operation to reset.

**Protocol:** The actual language of communication between devices, as distinguished from the electrical standard.

**RS-422(properly EIA-422):** A wiring and electrical standard for digital communication in a multi drop environment. It is a 4-wire system equivalent to two RS-485 links, available in one cable. It allows communication transmission on one pair and receiving on the other.

**RS-485 (properly EIA-485):** A wiring and electrical standard for digital communication in a multi drop environment. It is a 2-wire system, with a differential signal allowing relative immunity to variations in grounds between devices. RS-485: maximum 32 transceivers per loop, 4000 ft (1300 meters) max. 120 ohm line termination required. (Line termination resistors are available on all M-Series devices via selectable jumpers).

**Stub:** A short wiring link branching from the main line.

**Upload:** Sending data files ‘up’ to a master device, as to a computer.

**Voting:** When more than one sensor and setpoint is assigned to a relay, then voting defines how many must reach the setpoint before the relay actuates.

**Window:** When we want the relay to actuate between two setpoints. e.g. with setpoints at 50 and 100, the fan will operate only between 50 and 100. Not a feature of M-Controller.

## 2 General System Overview

QEL’s M-Series gas monitoring system is a set of remote sensors and relay control modules tied together and controlled by the M-Controller. M-Series sensor/transmitters comprise a group of remote mountable sensors complete with electronics, most of which have both analog and digital communications, and most of which have display and onboard relay options.

The M-Controller is a flexible programmable controller with capability to work with up to 32 M-Series digital sensor/transmitters and up to 8 analog (4-20 milliamps) linear input signals for a total of 40 sensors. With three on-board relays, the controller can also direct up to 12 remote relay modules (M\_Relay), each of which may have up to 8 relays. With the same RS-485 interface, the controller can also communicate with M-Series Annunciator Panel (MAP) that is a device, located at some distance from the M-Controller and provides a user an audible and visual indication of the status of the M-Controller. The M-Controller can also work with M-NET so that the M-Controller can communicate with serial devices over a LAN or WAN by using TCP/IP or UDP/IP protocol, this allows traditional Windows PC software, such as M-View, access to M-Controller anywhere on the LAN/WAN network.

Additional features include 24 VDC transistor outputs for strobe light and horn, RS-422 connection for a MODBUS RTU master for data collection, and an RJ-11 phone jack for uploading and downloading the configuration database through RS-232 or Ethernet with M-Net. The configuration may be altered either through a computer or through the front panel keypad.

Power supply is designed for 24VAC or 24 VDC for all devices in the system. QEL can supply a transformer for external mounting sized to the application if requested. See below.

### 3 M- Controller Specifications

**Power Supply:**

Voltage: 24V ± 4V AC or DC  
AC Power must be non-grounded (Floating)

Amps:	Controller:	0.9 A
	Strobe & Horn	0.6 A
	Max Load per channel	2.0 A
	Max Allowed through controller	10.0A

Total actual power is dependent on the system design. Power may be supplied to sensors and relay modules through the M-Controller or each may have separate power supplies. Each type of sensor varies in it's power requirements.

**NOTE: CERTAIN QEL AND OTHER DEVICES OPERATE ON DC VOLTAGE ONLY. THE M-CONTROLLER DOES NOT CONVERT AN AC VOLTAGE INPUT INTO A DC VOLTAGE OUTPUT FOR THE REMOTE SENSORS.**

**24 VDC INPUT = 24 VDC OUTPUT**

**24 VAC INPUT = 24 VAC OUTPUT**

**E.G. THE QTS-1710 AND QTS-6000 OPERATE ON DC VOLTAGE ONLY.**

**Enclosure:** NEMA 1, steel, epoxy painted black

**Keypad:** 4 x 4 tactile & audible keypad

**Display:** 2 x 16 character display c/w backlight

**Panel Indicators:** 5 Status LED's (Red)

LED1: Relay 1

LED2: Relay 2

LED3: Relay 3

LED4: Hush

LED5: Fault

**On-Board Relays:** 3 Relays DPDT, Dry contacts  
5 amp resistive 240VAC, 30 VDC  
3.7 amp inductive 240VAC, 30 VDC

- Horn & Strobe:** 24VDC terminals are supplied for connection to standard strobe and horn set. 6 watts each.
- On-Board Buzzer:** 90 db at 30 cm, 2700 Hz  
Buzzer 1: Continuous  
Buzzer 2: Double-tap Intermittent  
Buzzer 3: Intermittent 50% duty cycle
- Remote Devices:** 4 Ports  
24VAC/DC  
RS-485
- Modbus Slave Port:** RS-422  
Responds as a Modbus Slave using RTU protocol. M-Controller supplies read status information only.  
**Note: Check the U10 RS-422 drive chip (close to the RS-422 Terminal Block), if the chip is DS8921, the terminal TB11 labels correctly; if the chip is SN75179, the terminal TB11 TX+ and TX- should be inverse.**
- RS-232 Interface:** RJ-11 Telephone jack.  
Disables the RS-422 port. Can be used for MODBUS RTU.  
Primarily used for uploading and downloading large configuration databases.
- Analog Output:** Optional added circuit card to support 8 channels of 4-20 milliamps. The signals may be isolated as a group by using a separate isolating transformer (supplied by others) as necessary.

## 4 M-Controller Analog Output Option Card

The M-Controller has an optional card for eight channels of 4 – 20 milliamp analog outputs. These will drive into a minimum of 700 ohms with a power supply of 24 VDC. Each analog output may be defined in complex ways allowing averaging of input signals or peak among input signals and assignment of different values to both 4 milliamps and 20 milliamps. You may even assign a gas concentration to 4 milliamps which is higher than the concentration assigned to 20 milliamps. The M-Controller will draw a straight line between.

### 4.1 Specifications

#### Power Supply:

Voltage: 24 VAC/VDC  
AC Power must be non-grounded (Floating)  
Amps: 0.25  
Isolatable System

#### Outputs:

8 Channels  
4 – 20 milliamps  
Common Return

#### Working Mode:

- Averaging Mode: Output the current according the averaging value of input signals
- Peak Mode: Output the current according the peak value among the input signals

### 4.2 Common Return Line

The eight channels have a common return line to circuit card negative.

### 4.3 Isolating the Signals

It is possible to isolate the Analog Output signals from the M-Controller by supplying the circuit card from a second – external – power supply. i.e. If your monitor or other device has a different ground than the M-Controller, then supplying another transformer (floating) or DC supply grounded at the second ground allows the card to operate independently.

**Note: There are two field changeable shunts/jumpers on the circuit card which key for either internal power (supplied from M-Controller) or external power. It is essential that these be set appropriately. Factory default is Internal Power.**



## 6 M-Controller Functions

### 6.1 System Setup

#### 6.1.1 Miscellaneous

**Password:** Default password is 4321.

**Baud rate:** Host Computer bps: default baud rate is 57K6 bps

**Baud rate:** Remote Sensor bps: default baud rate is 4800 bps

**Screen Scroll Rate:** in normal operation the sensor and relay status information scrolls automatically. Set the number of seconds for each item to be displayed.

**LCD Backlight Mode:** The LCD backlight can be set to always Off, always On and Power Saver. In Power Saving mode, the backlight will turn On for 10 seconds after any key has been pressed. Default setting is power saving mode.

#### 6.1.2 Calibrations

These values are established during factory calibration and should not require recalibration in the field. Do not attempt to modify these settings in the field.

Analog Input 4 mA  
Analog Input 20 mA

Analog Output 4 mA  
Analog output 20 mA

### 6.2 Relay Configurations

Relay configurations may be styled in two basic ways: Voting and Averaging. Each method allows certain advantages and limitations. Common functions apply to both styles.

#### 6.2.1 Common Functions

**Delay on Actuation** ('Delay on Make'). For each relay a separate time delay may be set up to 60 minutes before an alarm condition will cause the relay to actuate. Default is 00 minutes

**Delay on De-Actuation** ('Delay on Break'). For each relay a separate time delay may be set up to 60 minutes before a return to a non-alarming signal condition will cause the relay to de-actuate. Default is 00 minutes.

**Normally/Not-Normally Energized.** Each relay may be individually set to be Normally or Not Normally Energized.

**Latching:** Each relay may be set to latch in Actuate status until acknowledged by a front-panel action. Hold the “**Clear**” key for 3 seconds.

### 6.2.2 Voting

**Voting Number:** For a given list of sensors assigned to a relay actuation list, this number indicates the minimum number of sensors which must pass or equal their alarm “On” concentration before the relay will actuate.

**Assign Sensor:** Each relay may be assigned to any one or more of the **enabled** sensors or analog inputs in the database.

***If On Concentration is great than or equal to Off Concentration:***

**On Concentration:** For each sensor or analog input assigned, set the concentration at or above which the relay will actuate.

**Off Concentration:** For each sensor or analog input assigned, set the concentration at or below which the relay will de-actuate.

***If On Concentration is less than Off Concentration:***

**On Concentration:** For each sensor or analog input assigned, set the concentration below which the relay will actuate.

**Off Concentration:** For each sensor or analog input assigned, set the concentration above which the relay will de-actuate.

**Fault Actuation Flag:** For each sensor set this flag for actuation if the sensor reports Fault or drops off-line. In case of a dedicated Fail relay, then set the On and Off concentrations to zero (0) to disable actuation on gas concentration for that sensor.

### 6.2.3 Averaging

Averaging is default. Voting is disabled and Voting Number is forbidden automatically. Input values to “Average On”, “Average Off”. Note that the user must assign sensors with the same gas type and same units only.

***If Average On is great than or equal to Average Off:***

**Average On:** The gas concentration at or above which the average of all the sensors assigned to this relay will cause the relay to actuate.

**Average Off:** The gas concentration at or below which the average of all the sensors assigned to this relay will cause the relay to de-actuate.

***If Average On is less than Average Off:***

**Average On:** The gas concentration at or below which the average of all the sensors assigned to this relay will cause the relay to actuate.

**Average Off:** The gas concentration at or above which the average of all the sensors assigned to this relay will cause the relay to de-actuate.

## **6.2.4 Sensor Configuration**

**Sensor Enable:** The M-Controller must be told that a sensor is attached to the communication system.

**Gas Type:** The M-Controller is told what gas type to expect. It will compare this with what the sensor reports and will flag a fault if they don't agree. . It can also be customer defined Gas Type with not more than 3 characters. This function is only supported with M-View, you can not input customer defined gas type though keypads. When the Gas Type is customer defined, the M-Controller will not check the mismatch of Gas Type.

**Gas Units:** The M-Controller must be told what units of measurement to display. It can also be customer defined Gas Unit with not more than 3 characters. This function is only supported with M-View, you can not input customer defined gas unit though keypads.

## **6.3 Analog Input Configuration**

**Channel Enable:** The Controller must be told which channels are active.

**Gas Type:** Set the gas type for the display. It can also be customer defined Gas Type with not more than 3 characters. This function is only supported with M-View, you can not input customer defined gas type though keypads. When the Gas Type is customer defined, the M-Controller will not check the mismatch of Gas Type.

**Measure Units:** Set the units of measurement for the display. It can also be customer defined Gas Unit with not more than 3 characters. This function is only supported with M-View, you can not input customer defined gas unit though keypads.

### **Measure Range:**

Assign the two readings at 4.0 milliamps and 20.0 milliamps input signal. You may even assign a gas concentration to 4 mA, which is higher than the concentration assigned to 20 milliamps. The M-Controller will draw a straight line between.

## **7 Sensors and Addressing**

The term “sensor” used throughout means a digitally communicating sensor unless otherwise stated

The M-Controller can support up to 32 remote digital sensors.

Acceptable addresses are 0 ... 31.

## **8 Analog Inputs and Addressing**

The M-Controller can accept up to 8 analog inputs.

For operating display purposes the controller labels them as A01 to A08.

For relay configuration purposes, they are defined as Sensors 32 ... 39.













## 9 M-Relay Functions and Addressing

The M-Relay modules are designed to allow expandability for control to the M-Controller. Controlled over an RS-485 communication link they allow flexibility in installation and wiring. They operate from 24 VAC/VDC and may be powered via the port power of the M-Controller or directly from a local power source.

Each relay module is addressed as a module number from 0 to 11. The module address is defined on a four-position dipswitch on the circuit card. Each relay module may contain up to 8 relays.

Relay numbering from the standpoint of the M-Controller is numbered consecutively with numbers 1, 2 and 3 being the M-Controller internal relays and numbers 4 through 99 the relays in the remote modules.

The following table indicates the relationships.

Module Address	Dipswitch Setting	Relay Numbers per M-Controller Menu Assignments	Module Address	Dipswitch Setting	Relay Numbers per M-Controller Menu Assignments
0		4 to 11	6		52 to 59
1		12 to 19	7		60 to 67
2		20 to 27	8		68 to 75
3		28 to 35	9		76 to 83
4		36 to 43	10		84 to 91
5		44 to 51	11		92 to 99

## 10 Keypad Operation and Configuring the Databases

All database programming and configuration can be done through the front panel keypad, although this is practical only for short programs and program modifications. The following discussion and flow charts demonstrate the operation and menu pathways. In practice you will find that it is easier to use the keypad and menus than it is to read the reference descriptions. The menus provide prompting at each stage, and only a few rules need be memorized.

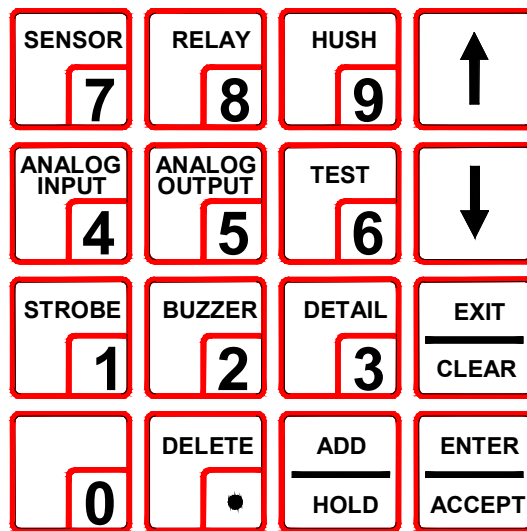

The menu is structured into two sections:

**Status View and Acknowledge:** A set of quick keypad commands which allow detailed views of status, and acknowledge and ‘hush’ functions.

**Configuration:** Password controlled access to all the database setup and configuration menus.

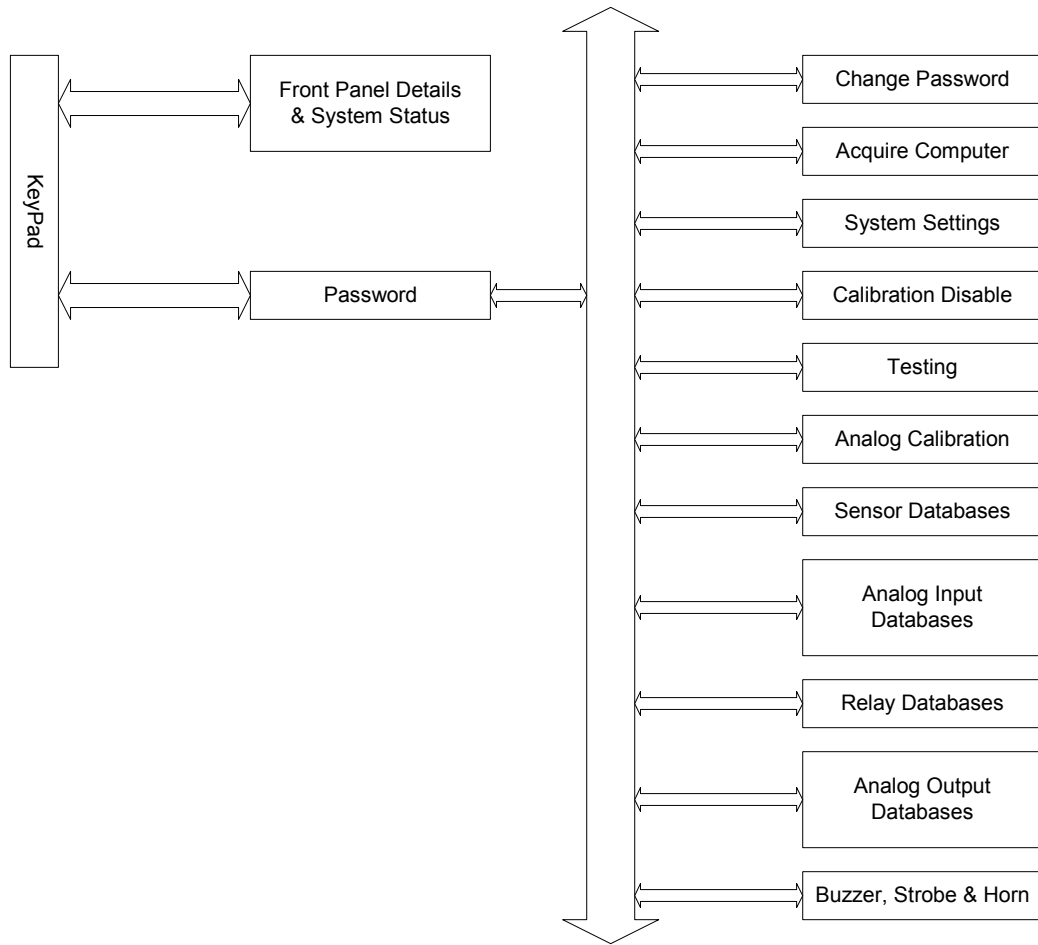

### 10.1 Status View and Acknowledge Commands

In normal operation the display appears as follows.



Where

- Snn = the Sensor number/address
- Rmm = the Relay number
- xxxx = the Gas concentration
- uu = units of measure
- yyyy = either the gas type, or r1, r2 then indicating Relay 1 and Relay 2 sensor relays or setpoints (if present) are actuated
- zzz = relay status

#### Example



Sensor 13 reports 127 ppm. On-sensor setpoints 1 and 2 have been actuated.

Relay 23 setpoint has been reached, but is counting through delay before actuation.

## SCROLL AND HOLD

Press **up** or **down** to scroll through the display items. Note that the upper line of the display and the lower are independent, but will scroll at the same time.

Press **Hold**. The display will stop at that point for 2-3 minutes, displaying the ongoing status of both top and bottom lines.

## View and Hold Status

There are six keyboard short cut commands to view the status of individual devices. Note the keys labeled **Sensor**, **Relay**, **Analog Input**, or **Analog Output**. Press the key followed by the address number (“NN”) then ‘Enter’. The display line will jump to that device and hold for 2 – 3 minutes. Note that Inputs are assigned to the top line, and outputs are assigned to the bottom line. It is therefore possible to view and hold an input and an unrelated output at the same time.

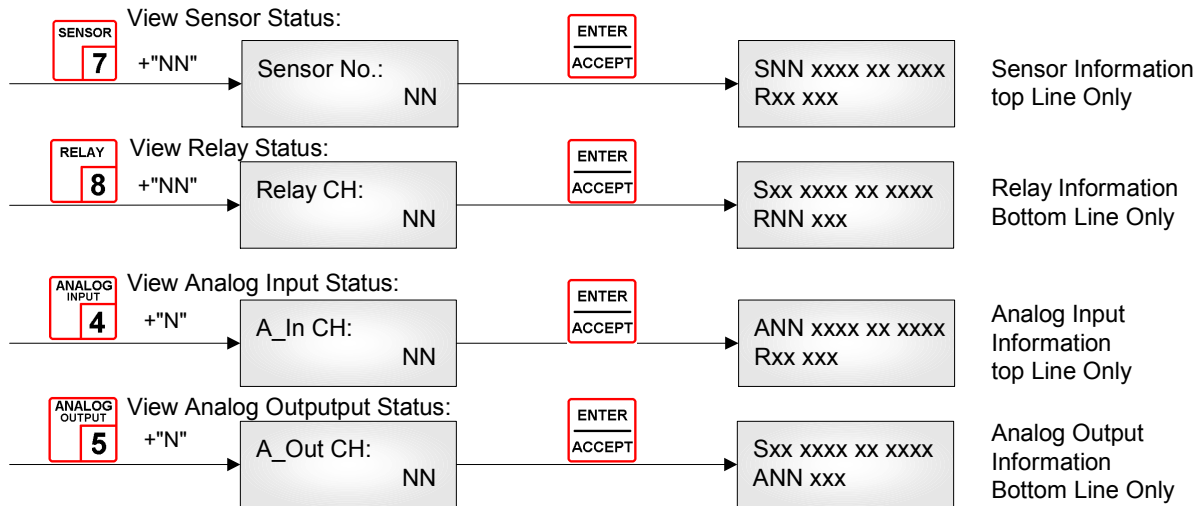

In the case of the Strobe, there is no need to enter an address, as there is no other strobe.



In the case of the Buzzer, as with the Strobe, there is no need to enter an address; pressing Buzzer again will cycle through the three Buzzer modes.

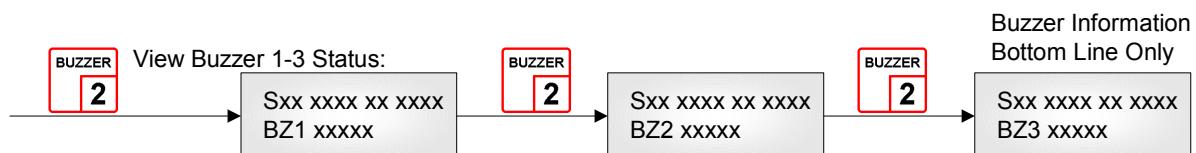

## VIEW OUTPUT DETAILS

It is also possible to get a snap shot view of all the program details for a given output such as relay, buzzer or strobe. First choose an address either by scrolling through the list or by directly keying in the address as above. Then press “**Details**”.

Pressing **Details** cycles one through three display screens giving the following information.

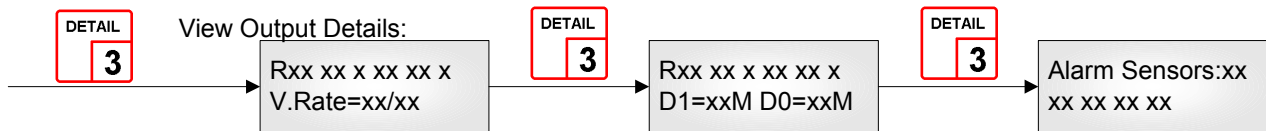

Rxx yy v zz ww L

Where

xx = relay number

yy = NE or ND

where NE = Normally Energized

ND = Normally De-Energized

V = V or A

where V = Voting number in Voting Mode

A = Averaging Mode

zz = D1 = On Delay has been set

= DX = Off Delay has not be set

ww = D0 = Off Delay has been set

= DX= Off Delay has not be set

L = L or nL

where L = latching

nL = non-latching

The first display will show either of the two below depending on whether the relay is in Voting mode or in Average mode

V. Rate = xx/yy

Voting Mode only. e.g. 13/10 indicates that 13 sensors have passed the alarm threshold of 10 required for voting.

A=xxxx yyyy/zzzz

Where

Average Mode only.

xxxx = the present measured average concentration

yyyy = the Relay Actuate Average On Concentration

zzzz = the Relay De-Actuate Average On Concentration

The Second display will show the current delay status.

D1 = xxM

The number of minutes assigned to the On delay

D0 = xxM

The number of minutes assigned to the Off delay

The third “Alarm Sensors” display is only shown if the relay is in **Voting Mode**

Alarm Sensors xx  
yy yy yy yy

Where           xx = the actual number of sensors currently in alarm  
                  yy = the list of those sensors which are in alarm.

Press **Up** or **Down** keys to scroll through the details for other outputs.

### LATCHED RELAY RESET

To acknowledge a latched condition, press the **Exit/Clear** button for 3 seconds. All latched relays for which the alarm condition has been removed will reset. If the alarm condition (e.g. high gas concentration) is still present the relay(s) will not reset.

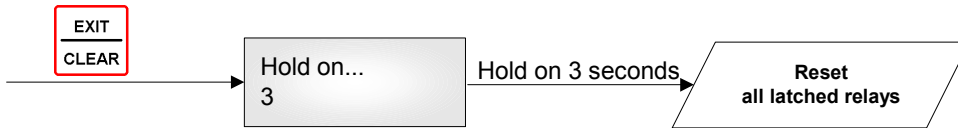

### HUSH BUZZER AND HORN

Press the **Hush** button to silence the buzzer and horn.

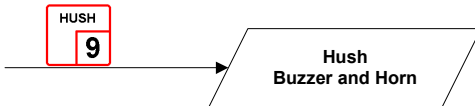

## 11 Database Configuration Menu Tree

Changing database items is password controlled. Press **Enter** for 3 seconds. You will then be prompted for a four-digit password. Once accepted you are into the main menu tree. Press **Up** or **Down** to scroll through the main branch headings. Factory default password is 4321.

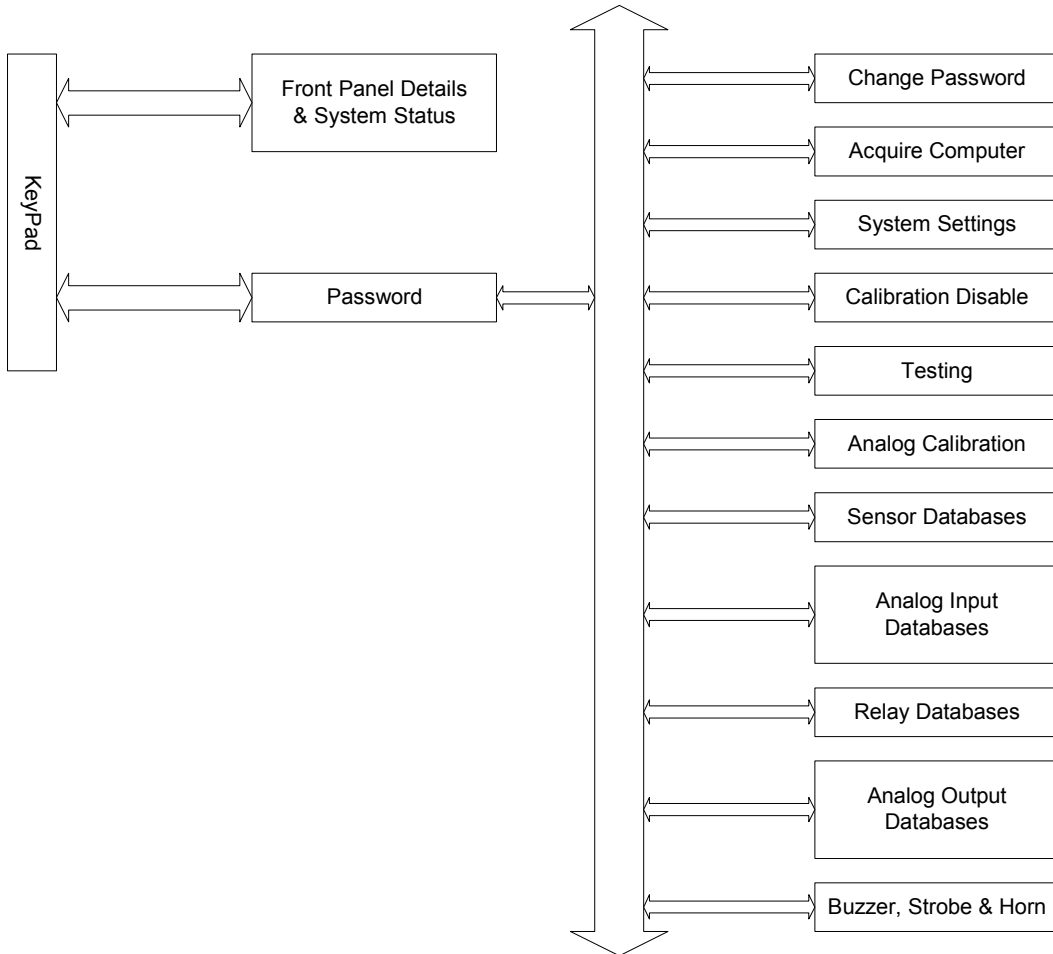

**Note that while in the Menu Tree, all normal monitoring operations stop. The alarm status does not change.**

**Note that when queried (Y/N) in any of the menus Accept = Y and Exit = N**

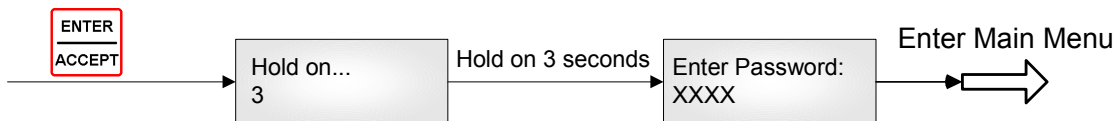

## 11.1 Explanation of Display

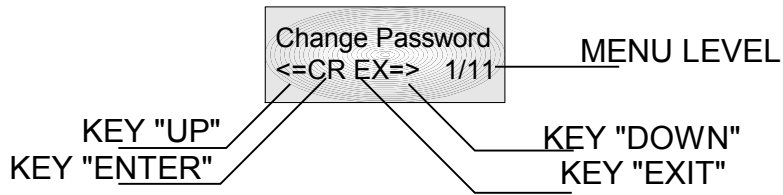

When the LCD displays the four symbols, it means the four keys are available to access.

## 11.2 Change Password

Change password allows any combination of up to four digits. **WARNING** be sure that you record the new password in a safe and secure location!

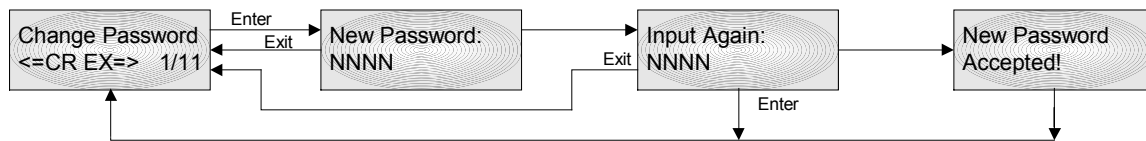

## 11.3 Acquire Computer

In order to upload and download databases from a computer (see QEL's M-View software package), M-Controller must be told to "acquire" the computer port. The microprocessor functions for the communications to the computer utilize the same pins on the microprocessor as for the RS-422 Modbus interface. You can have communication to the computer based M-View program or you can have communications via RS-422 to Modbus, but you cannot have both at the same time. In "acquiring the computer" you disable the RS-422 MODBUS interface. The RS-232 connection through the RJ-11 telephone jack will now be enabled.

**It is necessary to exit from the menu tree to enable the monitor to run in normal operation and to communicate with the computer.**

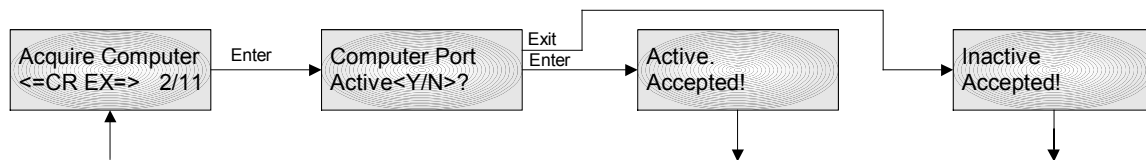

If the computer port is already inactive, then the screen will query **Active (Y/N)?** if the port is already active then the screen will query **InActive (Y/N)?**

## 11.4 Calibration Disable

To disable the M-Controller functions for calibration, system testing etc. When operation is disabled, the relay, strobe, etc., status **will freeze in whatever state they are already in.**

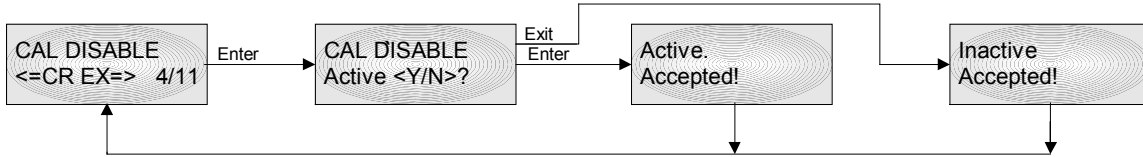

## 11.5 Testing (Force Outputs)

For system installation testing, it is necessary to force relay, buzzer and strobe actions. Enter this branch as shown in the flow diagram. **Strobe** and **Horn** tests are simple forces as shown. Relay testing is more complicated

The **Relay Testing** feature allows the user to force actuation on one or many relays. This function forces an actuate vs. de-actuate action, not an energized vs. non-energized action. Therefore the user must be aware of those relays which have been defined as normally energized or not normally energized. As seen from the flow diagram, one may continue to add relays to the list as required. Press Enter without choosing an address number to activate the entire list.

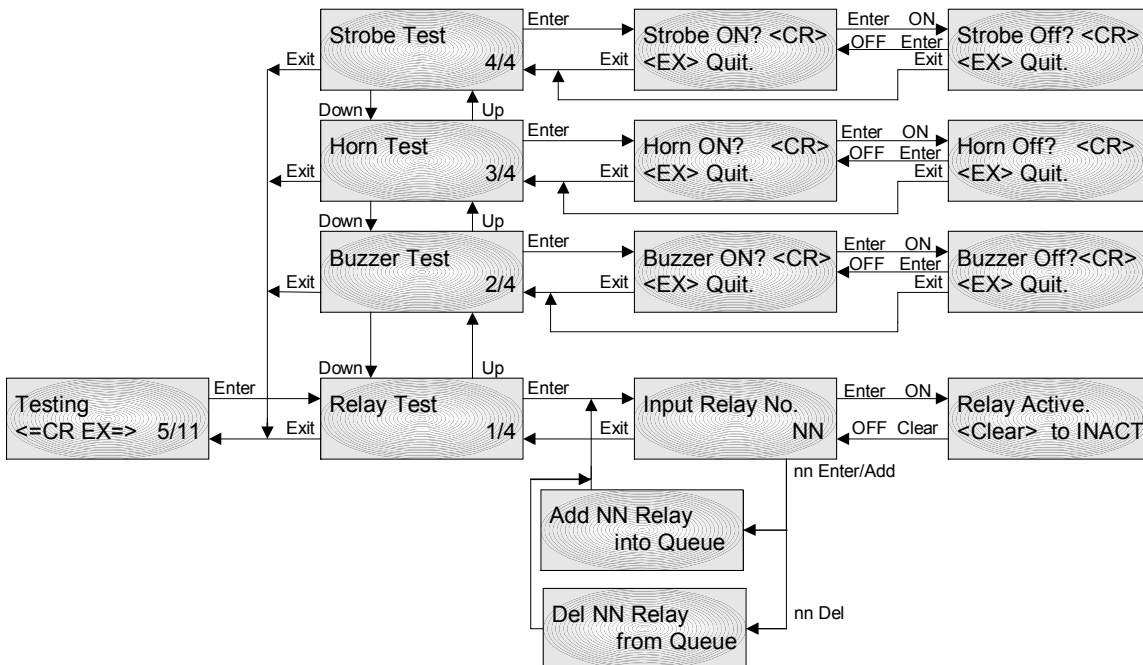

## 11.6 How to Create Database

The base concept is to tell the M-Controller it has sensors and what they are. Then tell the M-Controller it has relays and how they will function. Finally tell the M-Controller how the sensors and relays work together.

Following these steps will help you to create your database quickly and easily.

### 1. Requirements Analysis.

Before you create your database, you should write out a requirements analysis.

- A. How many remote sensors are there in your system? For each sensor, list its address, gas type and unit of measure.
- B. How many channels of 4-20mA analog input? List their channel numbers, gas type, unit of measure, and range of measure.
- C. Do you need 4-20mA analog output? if yes, list the concentration of 4mA and the concentration of 20mA, and what kind of input signal it is? How many input signal?
- D. Do you need a remote relay board? 5 amp or 10 amp contacts? What kind of relay style? (Normally Energized? Latching? voting mode or average mode? time delay? How many minutes? List assigned sensors)
- E. Setup for Buzzer, Horn and Strobe. (voting mode or average mode? Does it need time delay? How many minutes? List assigned sensors)
- F. Setup system settings, such as password, host computer baud rate, remote sensor baud rate, screen scroll rate and LCD Backlight mode.

### 2. Enter the database.

The database can be input using M-View which is a database setup software with a friendly Man Machine Interface running on a PC computer, it supports downloading and uploading the database to/from M-Controller. The database can also be input through the keypad on M-Controller.

- A. Input data for all remote sensors.
- B. Input all analog inputs data.  
**Note: You must have enabled each required sensor or analog input before you can assign it to a relay or analog output function.**
- C. Setup all relay styles.
- D. Setup all analog outputs.
- E. Setup buzzers and strobe, Setup triggers if a M-Net is equipped.
- F. Setup system settings.

In M-View, the trigger database is for M-NET to send an email to alert you that the set points has been reached. If your system did not install M-NET, you do not need to setup the trigger database.

Below description is to show you the procedures of setup database through keypad.

## 11.7 Modify Sensor Database

In order to assign a sensor or analog input to any of the output devices (relays, buzzers, etc) the sensor must already have been enabled in the sensor database.

Enter the Sensor Database branch of the menu tree. You are prompted to enter a sensor address number. You enter the address by keying in the digits. When accepted you are then prompted to supply the Gas Type and Units by scrolling through the lists. The display briefly displays 'Accepted' or 'Deleted' and returns to the initial prompt screen.

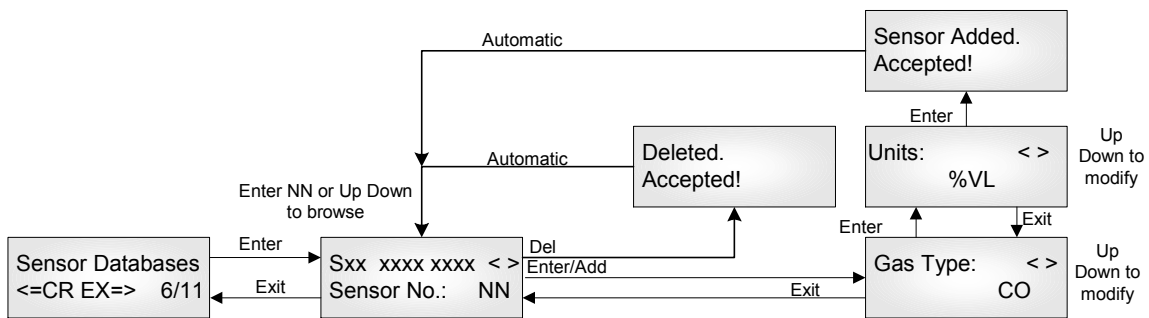

Where xxxx xxxx = Gas Type and Units of Measure

## 11.8 Modify Analog Input Database

Similar to the sensor database, you must have enabled an analog input before it may be used in the relay and other control databases. The pattern followed is the same except that you are invited to enter a Reading corresponding the value at 4.0 milliamps and 20.0 milliamps.

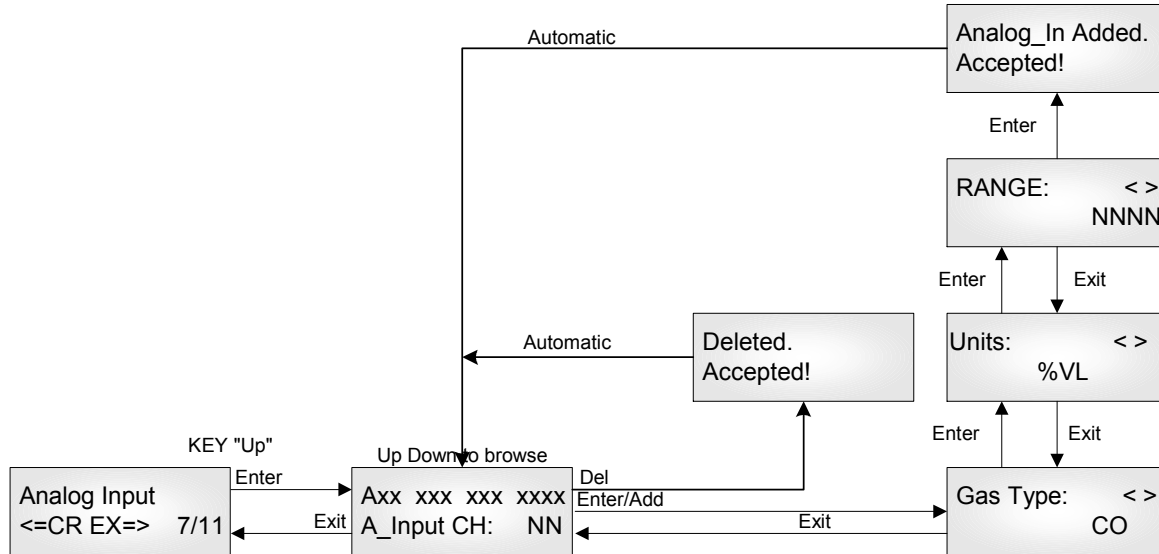

Where xxxx xxx xxxx = Gas Type, Units of Measure and Range

## 11.9 Modify Relay Database

The Relays and other output devices have two related databases: the **Style** which includes time delays, voting and so on, and the **Sensors** which lists the sensors which are assigned to that relay, together with the alarm settings associated with that sensor as applied to that relay only.

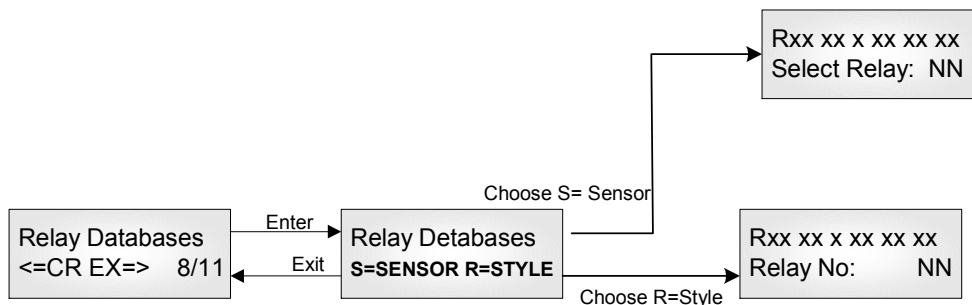

In both cases the next menu item invites you to select the relay number of the relay you are working with

### 11.10 Modify Relay Sensor Assignments

In this section you choose a relay number. You are then invited to choose sensors for assignment to the relay. For each sensor you must supply the Alarm On concentration, the alarm Off concentration (key in the digits and accept) and whether the relay is to react to a Fault condition. Note that **if the relay is to react to a Fault condition only, then set both Alarm concentrations to zero. Analog Input channel 1 to channel 8 will be presented by Sensor 32 to Sensor 39.**

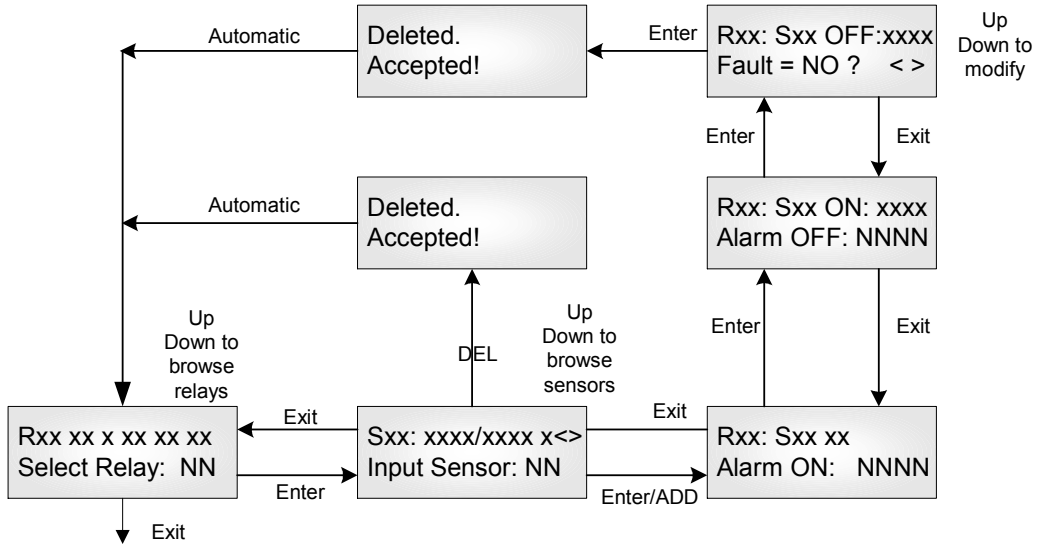

## 11.11 Modify Relay Styles

The following chart appears somewhat complex; however, on examination it becomes clear that the two tracks **Voting** and **Averaging** are mutually exclusive, and so the task becomes much simpler than it appears.

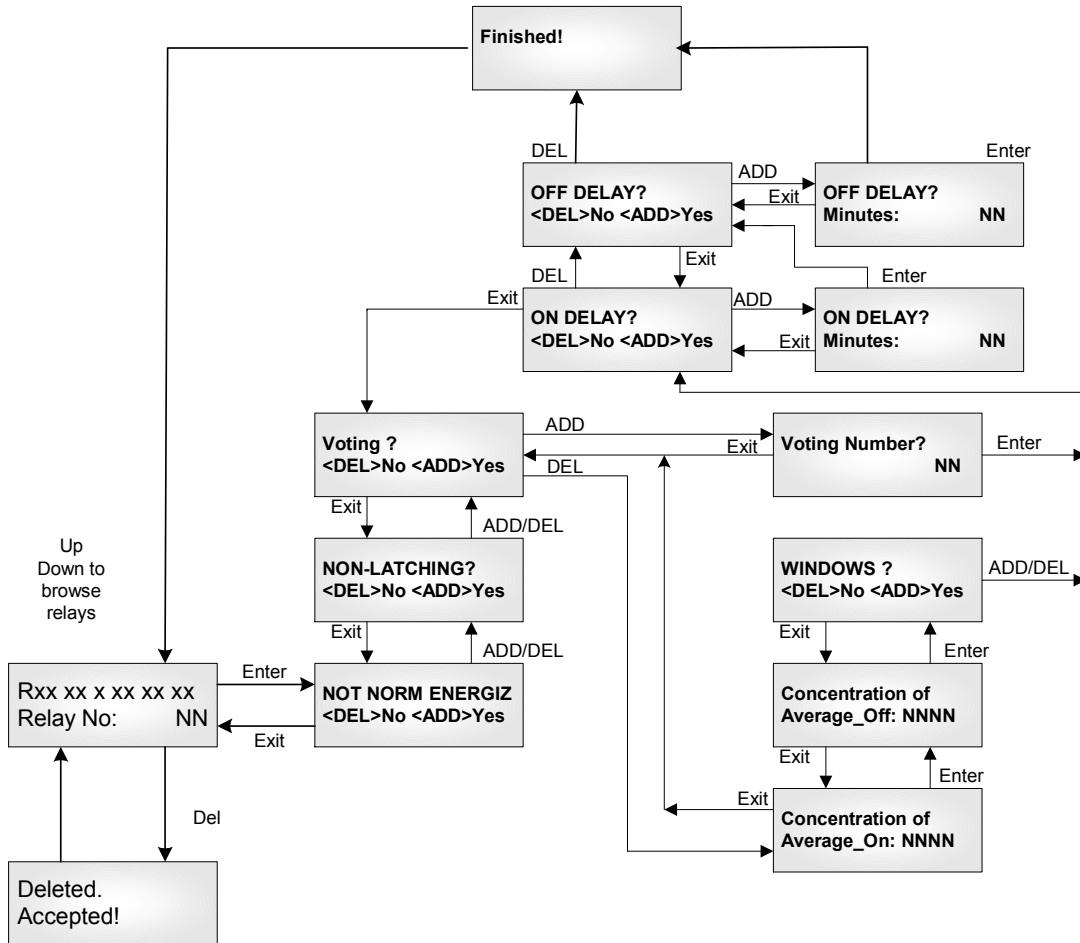

You are invited to choose a Relay address number, and then a series of features:

- Normally/Not Normally Energized
- Latching/Non Latching
- Voting/Non-Voting

Given Voting, then it enquires for the voting number.

Given Non-Voting, this means Averaging, and it then inquires for the On concentration and the Off concentration.

After which in both cases you are then led to determining whether there are any delays to be assigned. The term “On” refers to “Actuation” and “Off” refers to “Deactuation” not to whether the coil is energized or not.

### 11.12 Modify Buzzer Database

The buzzer setup is almost identical to that of the relays, except that there are three buzzer (one buzzer with 3 options) settings.

- Buzzer 1: Continuous
- Buzzer 2: Intermittent 50% duty cycle
- Buzzer 3: Double-tap Intermittent

Buzzer 1 has highest priority and Buzzer 3 has lowest priority.

The opening section of the branch is as follows, after, the menus are identical to those for the Relay database. Chose Sensor or Style and proceed.

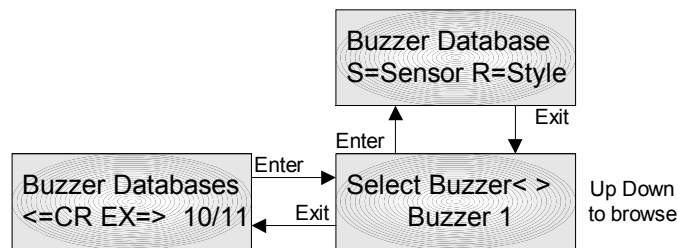

### 11.13 Modify Strobe Database

The strobe setup is almost identical to that of the relays, except that there is only one choice.

The opening section of the branch is as follows, after, the menus are identical to those for the Relay database. Chose Sensor or Style and proceed.

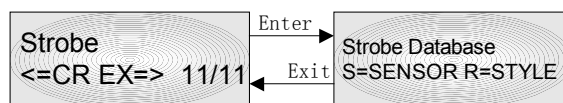

### 11.14 Modify Analog Output Database

Analog outputs may work with **remote sensors** of the same type or with **analog inputs**, but not both. In this case you are invited to choose a channel number and then to choose whether you want to work with Analog Inputs or with Sensors. You are able to assign more than one input per output channel. It is therefore extremely important to remember

to use only sensors or analog inputs measuring the same gas type, and for analog inputs, the signals which have the same range.

When you assign more than one analog or digital input to an analog output channel, the inputs **Could be averaged or taken the peak among the inputs inputs as the value to convert output current.**

For remote sensors, you must assign a concentration for both the 4.0 milliamp signal, and the 20 milliamp signal. You may assign a larger concentration for 4.0 milliamps than for 20 milliamps; the monitor will still stretch a straight line signal between the two points.

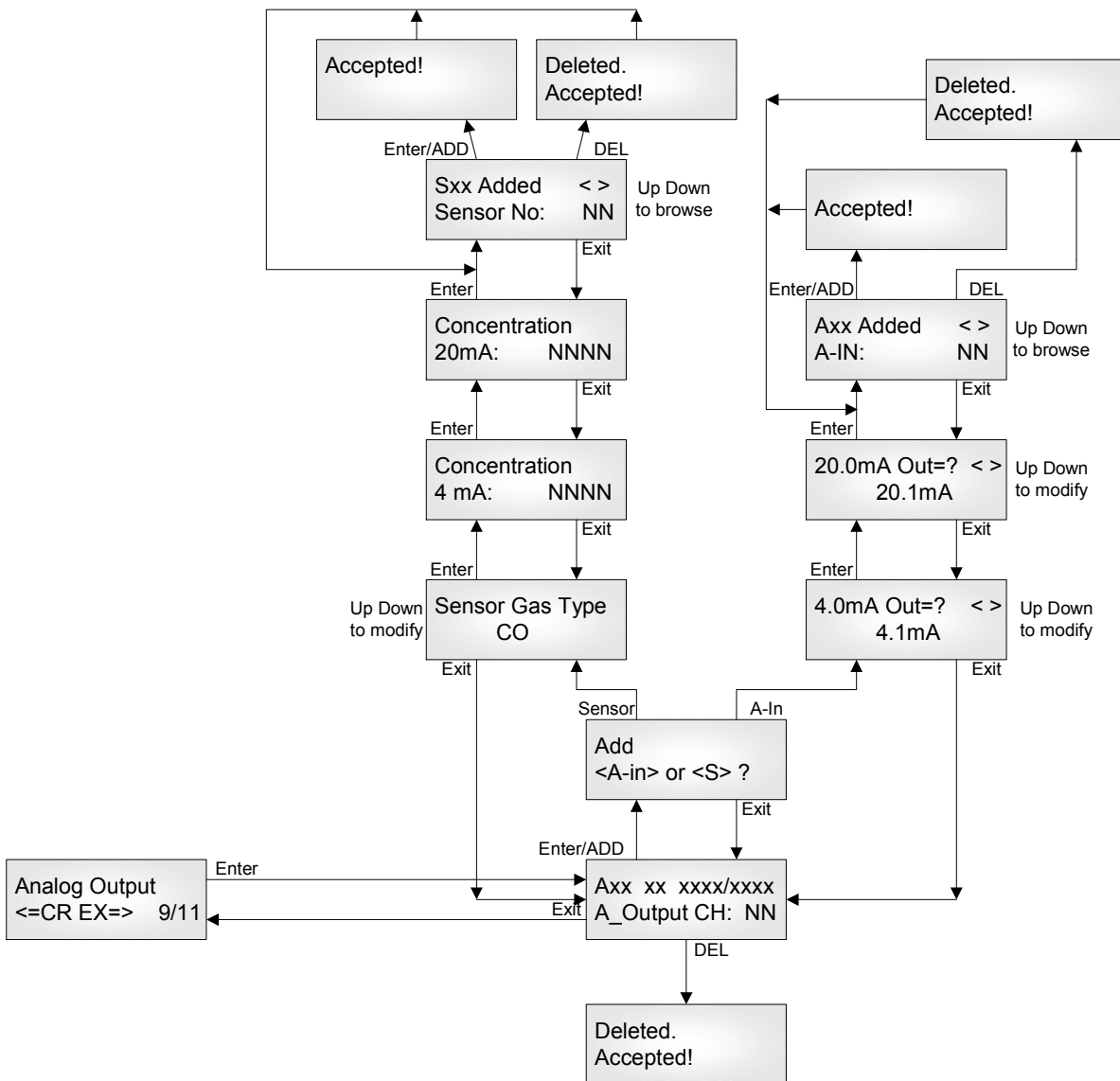

## 11.15 System Settings

**System Settings** contains general settings for monitor operations, communications and calibration.

### 11.15.1 Operating Configuration

Host Baud Rate	The communication rate to the host PLC or computer
Sensor Baud Rate	The communication rate to the remote sensor and other modules. This sets all four ports the same.
Scroll Rate	The rate at which the display scrolls through the sensor and relay status lines.
LCD Backlight	Allows choice of Always Off, Power saving, and Always On.
Modbus Slave Address	The digital address of the M-Controller for Modbus communications. Set between 1 and 255.

### 11.15.2 Calibration

4 mA Input	Apply precision 4.00 milliamps signal through Channel 1, press enter to store value.
20 mA Input	Apply precision 20.00 milliamps signal through Channel 1, press enter to store value
20 mA Output	Choose this item to output 20.00 milliamps from all analog outputs simultaneously. Adjust potentiometers on circuit card (if present)

**Warning: This procedure is part of factory setup. In most circumstances it will not be necessary to perform this procedure in the field. These functions require the use of precision reference instrumentation.**

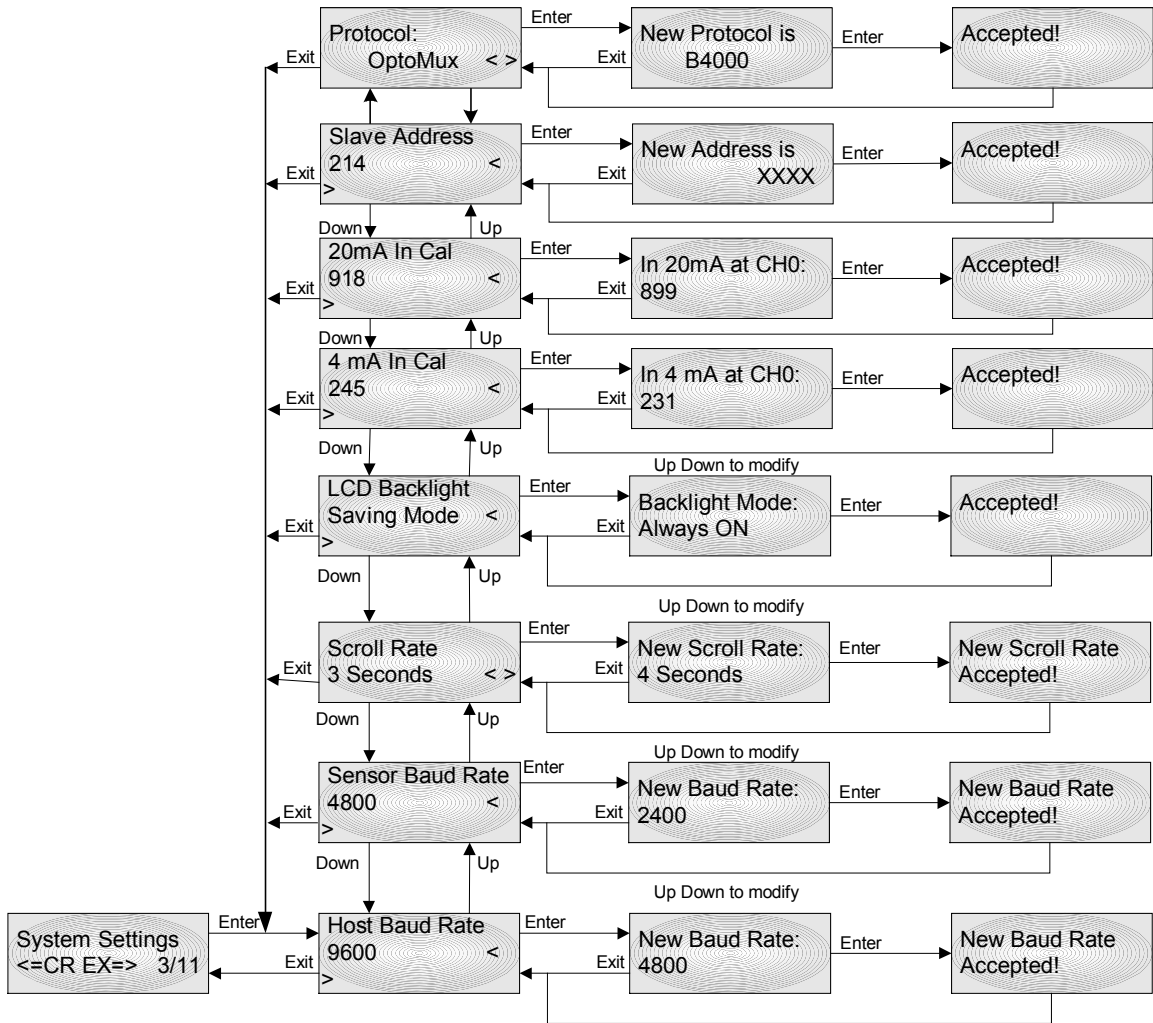

## 12 Computer Interface: Programming and Auditing

The M-Controller can be fully configured and programmed from the keypad; however, for even moderately complex networks this task becomes tedious. Therefore we have supplied an interface and computer program (**M-View**) to allow all database programming to be setup on a computer (laptop) and downloaded to the M-Controller.

QEL supplies interface adapters:

9-pin female (COM 1) to RJ-11 adapter

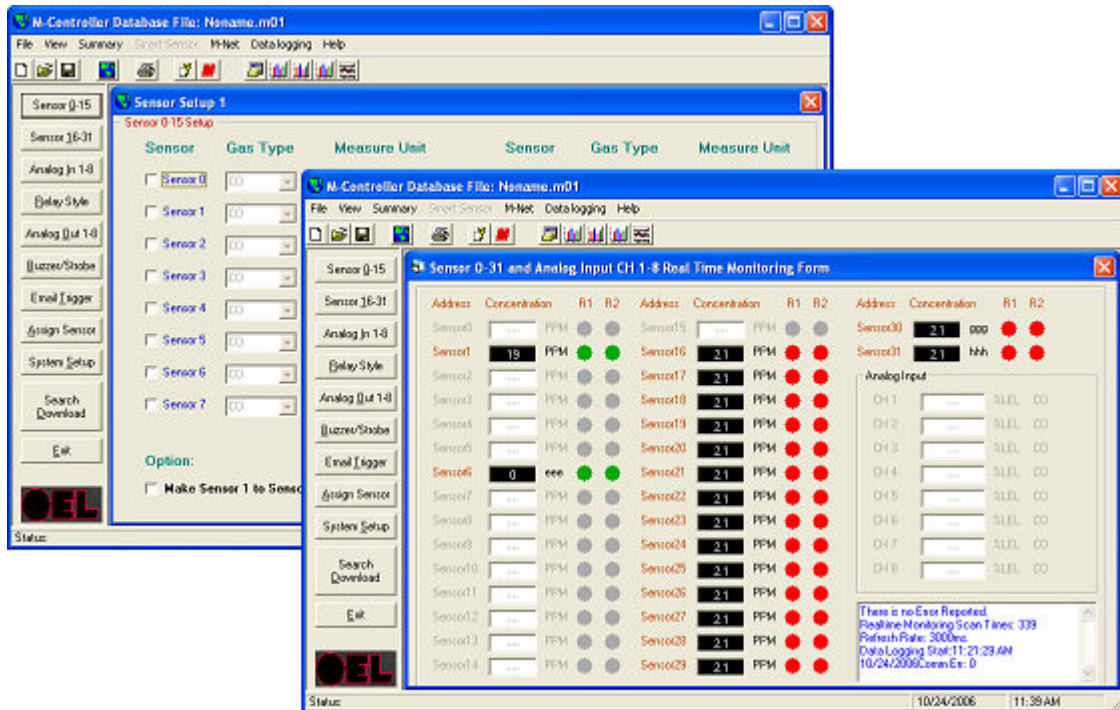

### 12.1 M-View

The M-View software has been designed as an easy to use configuration software package, greatly reducing the lengthy task of entering individual keystrokes through the keypad to quick configuration with the mouse. M-View allows for both programming and audit control, as you may download, upload and save programs to disk. Professional Version M-View also can Real Time Monitoring the current readings and statuses of M-Controller, Data logging these readings and statuses and Historical Data Review.

Standard Version M-View is limited to the three functions but have 5 minutes Real Time Monitoring function. The Standard Version M-View is free for all M-Controller users.

Minimum system requirements:

Operating System: Windows 98 or better  
Ram: 16 Megabyte of RAM  
Hard drive: 50 Megabytes free  
Speed: Any  
Mouse: Preferred (can navigate by [Tab])  
Spare Serial Port: COM1 to COM6

Note: If your computer has no serial port, call QEL for **USB to Serial Adapter**.

To install M-View, insert the CD into the computer and run Setup.exe. Follow the instructions on the screen.

***12.2 If your computer installed previous version M-View, the setup program will remove it first, then run Setup.exe again to install the latest version M-View.***

## M-Controller Setup

The M-Controller “Computer Port” must be configured to receive signals from the computer. The RS-232 port (RJ-11 telephone jack) is logically shared with the RS-422 Modbus port. Changing the setup will stop the Modbus communications.

Enter the main menu and choose

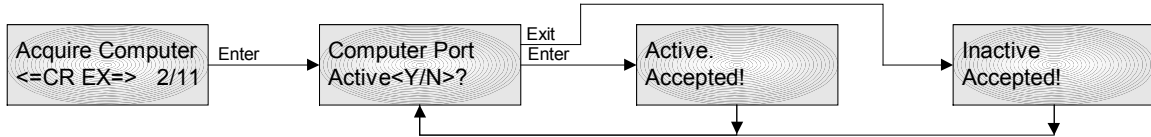

Make sure that the communications baud rate is the same for computer and M-Controller.

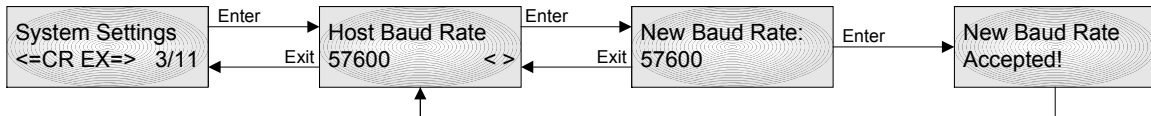

Then exit from the menu tree and return to normal operation. **The M-Controller will function normally except for this change.** You are now ready to use M-View.

When you are finished using the computer you must ‘inactivate’ the computer port again in order to use Modbus. If Modbus is not used in your system, it is not necessary to configure it. You may leave the controller continuously in ‘Acquire Computer’ mode.

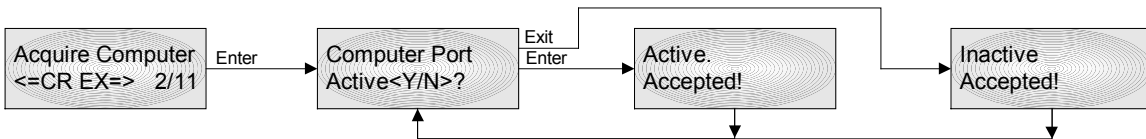

## 13 MODBUS Protocol Supported By M-Controller

### 13.1 Serial Transmission Mode

- Modbus RTU Slave Mode
- Baud rate: 19.2K, 28.8K, 38.4K, and 57.6K, selectable from Host Baud Rate Setting in System Setting Menu.
- Byte parity: Even parity.
- Data format: One start bit, 8 data bit, even parity bit, one stop bit, LSB first.
- Frame Check: CRC check.

### 13.2 Function Code Supported by M-Controller

- **#03 Read Holding Registers**

**Note: The command is only supported in the firmware V4.08 or later. If your M-Controller firmware version is lower than V4.08, please contact QEL to obtain an up-to-date firmware contained in M-View.**

Function in M-Controller: Read inputs and outputs statuses and readings, such as

- Relay Statuses
- Analog output current (mA x 10)
- Analog inputs readings
- Digital Sensor readings and statuses
- Buzzers, Strobe and Triggers statuses

Attribute: Read Only.

Broadcast is not supported.

Query:

Slave Address:	xx	(Default 214, check Slave address in M-Controller)
Function code:	03	
Starting addr. Hi:	000	
Starting addr. Lo:	xxx	(00 to 122)
No. of points Hi:	000	
No. of points Lo:	xxx	(01 to 123)
CRC check:	xxxxH	

Example: to read all holding registers in M-Controller (Slave Address: 214)

Query: [214] [003] [000] [000] [000] [123] [023] [206] in unsigned decimal.

### Holding Register Address Table

Modbus	Name	Description
40001	Relay1 and Relay 2 Statuses	Relay1 status in High 8 bits, Relay 2 status in Low 8 bits  Status Byte Definition: 0: Normal 1: Sensor Alarm 2: Communication Error 3: Offline 4: Sensor Gas type Error 5: Relay/Buzzer/Strobe/Trigger in On Delay process 6: Relay/Buzzer/Strobe in Off Delay process 7: Relay in Latched Status 8: Relay/Buzzer/Strobe/Trigger On 9: Relay/Buzzer/Strobe/Trigger Off 10: Relay/Buzzer/Strobe/Trigger in On Delay process (same as 5) 11: Relay/Buzzer/Strobe in Off Delay process (same as 6) 12: No Sensor is assigned to Relay/Buzzer/Strobe/Trigger 13: Buzzer is hushed 128: Disabled
40002	Relay3 and Relay4 Statuses	Relay3 status in High 8 bits, Relay 4 status in Low 8 bits Status Byte Definition see 40001
40003 to 40049	Relay5 to Relay98 Statuses	Relay5, 7, 9 ... status in High 8 bits, Relay6, 8, 10 ... status in Low 8 bits Status Byte Definition see 40001
40050	Relay99 Status	Relay99 status in High 8 bits, Low 8 bits is no use Status Byte Definition see 40001
40051	Analog Output CH1 and CH2 Statuses & mA reading	A-Out CH1 in High 8 bits, A-Out CH2 in Low 8 bits  Byte Definition: 0: Disabled Channel 1 – 255: Analog Output Current Value (mA) X 10 Example: If (Byte) = 200, the Analog Output value is 20.0 mA. If (Byte) = 41, the Analog Output value is 4.1 mA. If (Byte) = 0, the Analog Output is disabled.
40052 to 40054	Analog Output CH3 to CH8 Statuses & mA reading	A-Out CH3, 5, 7 in High 8 bits, A-Out CH4, 6, 8 in Low 8 bits Byte Definition see 40051
40055	Buzzer1 and Buzzer2 Statuses	Buzzer1 status in High 8 bits, Buzzer2 status in Low 8 bits Status Byte Definition see 40001
40056	Buzzer3 and Strobe Statuses	Buzzer3 status in High 8 bits, Strobe status in Low 8 bits Status Byte Definition see 40001

40057	Trigger1 and Trigger2 Statuses	Trigger1 status in High 8 bits, Trigger2 status in Low 8 bits Status Byte Definition see 40001
40058	Trigger3 Status	Trigger3 status in High 8 bits, Low 8 bits is no use Status Byte Definition see 40001
40059	Digital Sensor 0-7 Relay Statuses	Usually, Each Digital Sensor has two Relays onboard: <ul style="list-style-type: none"> <li>Relay High (H) and Relay Low (L)</li> </ul> bit(1): ON, bit(0): OFF b15...b8= Sensor 3H,3L,2H,2L,1H,1L,0H,0L b7...b0= Sensor 7H,7L,6H,6L,5H,5L,4H,4L
40060	Digital Sensor 8-15 Relay Statuses	B15...b8= Sensor 11H,11L,10H,10L,9H,9L,8H,8L b7...b0= Sensor 15H,15L,14H,14L,13H,13L,12H,12L
40061	Digital Sensor 16-23 Relay Statuses	B15...b8= Sensor 19H,19L,18H,18L,17H,17L,16H,16L) b7...b0= Sensor 23H,23L,22H,22L,21H,21L,20H,20L
40062	Digital Sensor 24-31 Relay Statuses	B15...b8= Sensor 27H,27L,26H,26L,25H,25L,24H,24L b7...b0= Sensor 31H,31L,30H,30L,29H,29L,28H,28L
40063	Digital Sensor 0 and Sensor 1 Statuses	Sensor 0 in High 8 bits, Sensor 1 in Low 8 bits Byte Status Definition: b7, b3 ... b0 is Sensor Status, Status Definition see 40001, b6, b5, b4 is Decimal Position for its Reading in 40083  example: b6, b5, b4 = 000, The actual reading is Reading in 40083 b6, b5, b4 = 001, The actual reading is Reading / 10 b6, b5, b4 = 010, The actual reading is Reading / 100 b6, b5, b4 = 011, The actual reading is Reading / 1000
40064 to 40078	Digital Sensor 2 – 31 Statuses	Sensor 2, 4, 6 ... in High 8 bits, Sensor 3, 5, 7 ... in Low 8 bits Byte Status Definition see 40063
40079	Analog Input CH1 and CH2 Statuses	A-In CH1 in High 8 bits, A-In CH2 in Low 8 bits Byte Status Definition see 40063
40080 to 40082	Analog Input CH3 - 8 Statuses	A-In CH3, 5, 7 in High 8 bits, A-In CH4, 6, 8 in Low 8 bits Byte Status Definition see 40063
40083	Digital Sensor 0 Gas Reading without Decimal	The Gas Reading is 16 bits signed integer. The Actual Reading of the sensor should be divided by its Decimal Position, see 40063
40084 to 40114	Digital Sensor1-31 Gas Reading without Decimal	Same as Definition in 40083
40115	Analog Input CH1 Reading without Decimal	The Reading is 16 bits signed integer. The Actual Reading of the Analog Input should be divided by its Decimal Position in 40079
40116 to 40122	Analog Input CH2-8 Reading without Decimal	Same as Definition in 40115

40123	M-Controller Self Diagnostics Report	<p>Fault Flag Reg.</p> <p>b0 = 1, no analog output daughter board plug in b0 = 0, normal</p> <p>b1 = 1, polling remote relay fault b1 = 0, normal</p> <p>b2 = 1, polling remote sensors fault b2 = 0, normal</p> <p>b3 = 1, remote sensor has fault b3 = 0, normal</p> <p>b4 = 1, no sensor assigned to an analog output b4 = 0, normal</p> <p>b5 = 1, no sensor assigned to a buzzer or a trigger b5 = 0, normal</p> <p>b6 = 1, no sensor assigned to the strobe b6 = 0, normal</p> <p>b7 = 1, no sensor assigned to relays b7 = 0, normal</p> <p>b8 ... b15 reserved</p>
-------	--------------------------------------	--

- #17(11H) Report Slave ID

Function in M-Controller:

Return a description of the type of controller present at the slave address with its specification.

Broadcast is not supported.

Query:

Slave Addr.:           xxH  
Function code:         11H  
CRC check:             xxxxH

Response:

Slave addr.:           xxH  
Function code:         11H

Byte count:	86H	
Slave ID:	80H	
Run Indicator status:	FFH	(always ON)
Software Version:	(2 Bytes)	major version first
Controller Serial Number	(2 Bytes)	high byte first
Special Gas Type [8][3]	(24 Bytes)	8 Special Gas Type
Special Unit [8][3]	(24 Bytes)	8 Special Unit
Gas Type	(40 Bytes)	Sensor 0 first, plus 8CH A_In
Unit of Measure	(40 bytes)	Sensor 0 first, plus 8CH A_In
CRC check:	xxxxH	

Note:

- 1). Slave ID = 80H for M-Controller in QEL
- 2). Each Special Gas Type or Special Unit is composed of 3 characters.
- 3). Gas type and Units Definition:

Value	Gas Type	Units
00H	O2	%Vol
01H	CO	PPM
02H	CO2	%LEL
03H	H2S	UNITS
04H	SO2	Special Unit 1
05H	NO	Special Unit 2
06H	NO2	Special Unit 3
07H	Hydrogen	Special Unit 4
08H	HCN	Special Unit 5
09H	HCL	Special Unit 6
0AH	NH3	Special Unit 7
0BH	MMH	Special Unit 8
0CH	O3	
0DH	C2H4O	
0EH	Cl2	
0FH	ClO2	
10H	CH4	
11H	C3H8	
12H	H2	
13H	Others	
14H	Special Gas Type 1	
15H	Special Gas Type 2	
16H	Special Gas Type 3	
17H	Special Gas Type 4	
18H	Special Gas Type 5	
19H	Special Gas Type 6	
20H	Special Gas Type 7	
21H	Special Gas Type 8	

## 14 Power Supply and Wiring

### 14.1 Power Requirements

The M-Controller power supply Voltage requirements are nominally 24 VDC or 24VAC. This increases flexibility in the field and reduces costs, especially in those areas where 24 VAC power is available as standard. In those situations where 24 VAC/DC is not already available it is necessary to purchase a power supply or transformer.

It is necessary to bear in mind the actual installation when sizing the transformer. The installation requirements can run theoretically from only 15 VA to over 200 VA. These systems ranging from a single controller, a few electrochemical sensors with no external relays to a full 32 QTS-8000 Combustible sensors with several remote relay modules.

The accompanying table allows the user to calculate power requirements for the system as an aid in sizing the transformer or power supply. Note the addition of a line at the bottom for 25% oversizing. It is always best to allow some safety margin in designing power supplies, and 25% to 50% allowance for startup surges and future requirements is recommended.

Device	Power Requirements Amps at 24VDC	Quantity	Total Power Requirements
<b>M-Controller- Standard</b>	0.65		
<b>Optional 4-20 Output</b>	0.25		
<b>M-Relay- 5 Amps</b> c/w 2 Relays	0.10		
c/w 4 Relays	0.15		
c/w 6 Relays	0.20		
c/w 8 Relays	0.25		
<b>M-Relay- 10 Amps</b> c/w 2 Relays	0.12		
c/w 4 Relays	0.20		
c/w 6 Relays	0.28		
c/w 8 Relays	0.36		
<b>External Strobe</b> <b>0.3A Max</b>			
<b>External Horn</b> <b>0.3A Max</b>			

<b>Remote Transmitters</b>			
M-18	0.080		
M-17	0.100		
M-5	0.080		
M-6	0.26		
M-20	0.100		
QTS-1810	0.125		
QTS-1710	0.125		
QTS-6000	0.25		
QTS-8000 Combustibles	0.200		
QTS-8000 Electrochemical	0.150		
<b>Total</b>			
<b>Safety Margin @ 25%</b>			
<b>Grand Total</b>			

### **14.2 Transformers**

QEL supplies one standard transformer

M-Transformer                      120 to 24 VAC    200 VA

### **14.3 Strobe and Horn**

QEL Supplies a standard audio and strobe alarm package.

M-Strobe	Lamp (Flashing)	24 VDC 6 W
	Audio	24 VDC
		85 dB @ 10'
		95 dB @ 1m

## 14.4 Analog Output Isolation

The M-Controller option circuit card for Analog Output has eight channels of 4-20 milliamp signals. These may be used as either isolated or non-isolated signals subject to certain constraints:

- The circuit board may be isolated or not isolated, but not individual channels.
- All channels have a common Return terminal.
- The isolation is achieved by supplying the circuit board with an external 24VAC power from a small transformer (5 VA) with both secondary connections floating.
- Make sure the jumpers are set according to the following diagrams.
- Separate 24VDC may be used for a clear separation of signal ground/return from M-Controller internal or local ground.
- See 84350-005-000-Rx (M-Controller Guidelines for System Design)

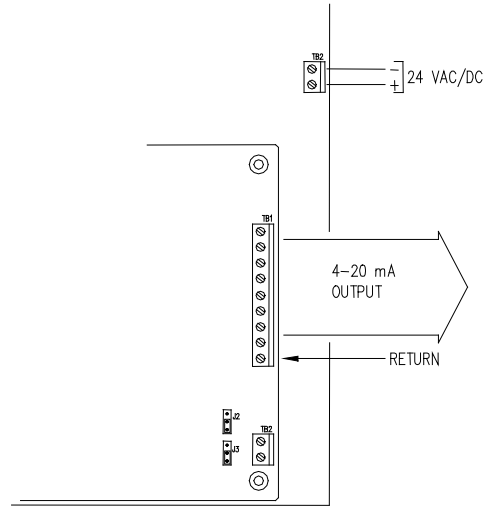

## 14.5 Analog Input Not Isolated.

The analog input accepts eight (8) channels of 4-20 milliamp signals. These inputs are not isolated and share a common ground. The 4-20 mA return line is connected to M-Controller Circuit Card Common.

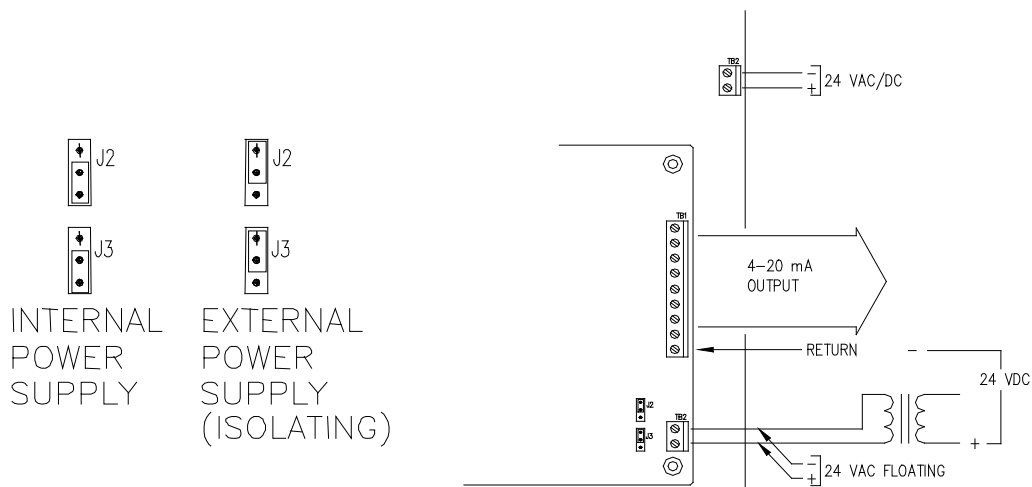

## 14.6 Grounding

- **M-Controller Common/Power Supply Negative is not connected to Chassis Safety Ground.**
- **Analog input Common is connected to M-Controller Negative.** Therefore the power supplies for remote devices should be powered carefully to prevent ground loops.
- Remote digital transmitters may have different power supplies and may have different grounds or may have floating power supplies. The RS-485 electrical standard allows differences between grounds of  $\pm 5$  Volts.
- Remote **Relay Module Negative is not connected to Chassis Safety Ground.**
- All metal chassis are supplied with a safety ground to the case.

## 14.7 RS-485 Installation

The RS-485 (EIA-485) standard specifies the electrical characteristics for a digital communication link allowing communication between multiple devices on a single link. The RS-485 uses two wires, A and B, and works on the voltage difference between them. If the voltage difference is positive, then that is a “1” if negative then that is a “0”.

**Ground Independence.** This scheme allows differences between grounds among the devices on the line of as much as  $\pm 7$  Volts; however, it is not wise to design that close to the tolerance, and we recommend keeping the differences within  $\pm 5$  volts.

**Wire Standard:** The cable standard is specified in the EIA-485 standard as twisted, balanced, shielded pair; with characteristic impedance of 120 ohms. Several manufacturers produce cable specifically for RS-485 installations. (e.g. Belden 9841).

Some people do use **Instrument Wire** for RS-485; however, a number of problems arise:

- The characteristic impedance is unknown and variable, and so the signals may not be robust, it becomes difficult or impossible to define an end-of-line matching resistance.
- Maximum installation distances are less, and somewhat unpredictable. Typically about one half that of proper cable.
- There is typically no significant cost saving, often the reverse.
- **QEL warrants and support only covers installation with proper cable. If in doubt please contact QEL support personnel.**

**Connections.** Wire terminals A to A to A etc., and B to B to B etc.

**End-Of-Line Termination Resistance.** A long wire behaves as an infinite series of inductors and capacitors, and so if nothing is done about it, the high speed digital signals cause a variety of peculiar effects such as positive or negative echoes and ringing. If we add a resistor across the terminals of the device at each end of the line which matches the characteristic impedance then the echoes and ringing are removed. For RS-485 cable this is 120 ohms. We need one at each end because the signal is bi-directional. **All QEL**

**equipment supplies the end-of-line resistor on the circuit card.** It is enabled or disabled with a shunt jumper. (See relevant Installation Drawings for information)

**Distances.** The RS-485 standard allows up to 1300 meters (4000 feet) of line length. It is best to avoid lines of this length if at all possible.

**Stubs.** Short lengths of cable from the main cable over to a device are called Stubs. When the Baud rate (communication bit rate) is low – e.g. 2400 baud, then it is often possible to use short lengths of a few inches without seriously impairing the signal integrity, especially when overall distances are relatively short; however, this is taking a chance on garbling your signals and is not recommended.

**Cable Shields:** Cable shields are aluminum and so only ‘proof’ against electrical fields, not against magnetic fields. The twist in the pair is to reduce the effects of magnetic fields. Take care not to run cable close to magnetic sources. Iron conduit is a good shield for both electrical and magnetic fields.

**Shield Grounding.** There are certain things to keep in mind for the shield.

- The shield must be grounded otherwise it can make the situation worse.
- Ground the shield at only one end to prevent ground loops.
- If you cut the cable then either ground each section of the shield at that point or connect the shields together to ground back at an origin point.

**Devices and Ports.** The RS-485 standard allows up to 32 devices on each communication line. The M-Controller does not need to be at the end of the line.

The M-Controller has four RS-485 ports; however, the M-Controller can only support a certain number of remote devices (32 sensors plus 8 relay modules) total. This is a limitation of the microprocessor capabilities, not of the wiring. The ports are logically parallel so that it does not matter which port a sensor is connected to. This allows flexibility of wiring to suit wiring for zones, and reduction of length of lines. Minimizing the installation total wiring distances increases the reliability of the system.

## ***14.8 RS-422 Installation***

The M-Controller has an RS-422 port for the Modbus connection. RS-422 is very like RS-485 electrically, except that there is a separate pair for transmit and a separate pair for receive. Therefore one port’s transmit is another port’s receive. One can use either two RS-485 cables or buy RS-422 cable (e.g. Belden 9842).

The same concerns and capabilities apply as for RS-485. RS422 devices cannot be used to construct a truly multi-point network. A true multi-point network consists of multiple drivers and receivers connected on a single bus, where any node can transmit or receive data. RS485 meets the requirements for a truly multi-point communications network,

**Note: Check the U10 RS-422 drive chip on the main board (close to the RS-422 Terminal Block), if the chip is DS8921, the terminal TB11 labels correctly; if the chip is SN75179, the terminal TB11 TX+ and TX- should be inverse.**

## 15 Troubleshooting Hints

M-Controller has advanced features and functions. Before assuming that unexpected behavior is caused by a system defect or breakdown, the operator should use this manual to become thoroughly familiar with M-Controller operation. This troubleshooting guide is intended as an aid in identifying the cause of unexpected behaviour and determining whether the behaviour is due to normal operation or an internal or external problem.

Identify the symptom or unexpected behaviour you are observing from the **SYMPTOMS** listed in the table. A **PROBABLE CAUSE** is provided and a suggested **SOLUTION** is proposed including references to manual sections that provide information that may be of assistance.

<b>SYMPTOMS</b>	<b>PROBABLE CAUSE</b>	<b>SUGGESTED SOLUTION</b>
LCD Display does not come on	<ul style="list-style-type: none"> <li>No power supply</li> <li>LCD has problem</li> <li>Program has crashed</li> </ul>	<ul style="list-style-type: none"> <li>Check power / ground connections</li> <li>Change LCD</li> <li>Reprogram</li> </ul>
M-View reports "M-Controller is offline"	<ul style="list-style-type: none"> <li>M-Controller is not turned on</li> <li>M-Controller is working in Menu Mode.</li> <li>Acquire computer is not active.</li> <li>Comm setting is wrong</li> </ul>	<ul style="list-style-type: none"> <li>Turn on M-Controller</li> <li>Exit Menu mode to Monitoring mode</li> <li>Active acquire computer in Menu mode and Exit to monitoring mode</li> <li>Check M-Controller is connected properly. Be sure that the port on the computer is active. Confirm that the port baud rate setting is same as the host baud rate in M-Controller System Settings in this manual.</li> </ul>
M-Controller reports "Vote no Sensor!" or "AV no Sensor!"	<ul style="list-style-type: none"> <li>No sensor was assigned to the output (relay or analog output)</li> </ul>	<ul style="list-style-type: none"> <li>Assign sensor to the output</li> </ul>
M-Controller reports "Sensor Offline" or "Relay Offline"	<ul style="list-style-type: none"> <li>Comm setting is wrong</li> <li>Connection is wrong</li> <li>Remote Device is in Fault</li> <li>End-of-line matching resistors are not properly set.</li> </ul>	<ul style="list-style-type: none"> <li>Check the remote baud rate in M-Controller System Setting is same as the baud rate in Digital Sensor or M-Relay.</li> <li>Check connection between M-Controller and Digital Sensor and M-Relay. Make sure all have power on and no shorts or opens in wiring. Be certain that polarity for RS-485 connections is correct. A-A and B-B</li> <li>Examine remote devices</li> <li>Review end-of-line resistor settings</li> </ul>

## **WARRANTY STATEMENT**

The information contained in this manual is based upon data considered accurate; however, no warranty is expressed or implied regarding the accuracy of this data. All QEL equipment is warranted against defects in material and workmanship for a period of two years from date of shipment with the following exceptions:

Electrochemical Sensors (Toxic)	Six Months
Catalytic Sensors (Combustible)	One Year

During the warranty period we will repair or replace, at our discretion, any components or complete units that prove, in our opinion, to be defective. We are not liable for consequential or incidental damage to auxiliary interfaced equipment.

A returned material authorization number should be obtained from the factory prior to returning any goods. All return shipments must be shipped freight prepaid and a copy of the maintenance records should accompany the unit concerned.

Warranty should be considered F.O.B. the factory. Labour and travel time are chargeable for any field site visits required for warranty work.

### **LIMITED LIABILITY**

All QEL systems shall be installed by a qualified technician/electrician and maintained in strict accordance with data provided for individual systems in the form of installation/maintenance manuals. QEL assumes no responsibility for improper installation, maintenance, etc., and stresses the importance of reading all manuals. QEL shall not be responsible for any liability arising from auxiliary interfaced equipment nor any damage resulting from the installation or operation of this equipment.

QEL's total liability is contained as above with no other liability expressed or implied as the purchaser is entirely responsible for installation and maintenance of systems.

This warranty is in lieu of all other warranties, expressed or implied, and no representative or person is authorized to represent or assume for QEL any liability in connection with the sales of our products other than that set forth herein.

NOTE: Due to on-going product development, QEL reserves the right to change specifications without notice and will assume no responsibility for any costs as a result of modifications.

For further information or assistance, contact:

### **QUATROSENSE ENVIRONMENTAL LTD.**

5935 Ottawa Street, PO Box 749

Richmond, Ontario

K0A 2Z0

Tel: (613) 838-4005

Fax: (613) 838-4018

Email: [QEL@QELsafety.com](mailto:QEL@QELsafety.com)

Web: [www.QELsafety.com](http://www.QELsafety.com)