



Mini Pressure Transmitters

Anderson's HA "Mini" sanitary pressure transmitter is specifically designed for critical measurements in fractional size lines and is available with an autoclaveable option. The product can be ordered with 3/4", 1", or 1-1/2" tri-clamp connections as well as our CPM fitting. This eliminates the need for reducers or adapters, thus reducing hold-up volumes in small lines. Internal zero and span adjustments and easily accessible test points greatly simplify calibration and validation. 316 "L" stainless steel wetted parts are electro-polished to an $R_a=8$. Finally, since it's an Anderson "Pharmaceutical Series" product, every transmitter includes a calibration certificate and permanent tag at no charge. Complete specifications appear below, with an ordering matrix and dimensions on the reverse.



SPECIFICATIONS

Excitation:

10-40 VDC (Absolute), 24 VDC Nominal regulated or unregulated

Output:

4-20 mA DC, 2 wire with non-interrupting circuit verification test points

Loop Resistance:

0-700 ohms at 24 VDC

Wiring Connection:

16 AWG max.; Screw Terminal; Accessible via removable screw cap conduit housing

Recommended Cable:

22-24 AWG, foil shielded, and PVC coated.
(3/16 - 1/4 OD insulation)

Accuracy:

± 0.5% of full scale

Repeatability:

± 0.3% of full scale

Hysteresis:

± 0.10% of full scale

Linearity:

±0.10% of full scale

Stability:

±0.30% of calibrated range/6 months

Storage Temperature:

-40°C to 65°C (-40°F to 149°F)

Process Temperature Limits:

-1°C to 149°C (30°F to 300°F)
(Horizontal Mount recommended over 135°C (275°F))

Ambient Temperature Limits:

-18°C to 49°C (0°F to 120°F)

Effect of Temperature Change:

± 0.1 psig/5.5°C (10°F) typical

Over-Range Rating:

2 times base range

Response Time:

200 uSec

Wetted Parts:

316L stainless steel electropolished
(R_a max. = 8 microinches, .2 microns)

Housing Material:

304 stainless steel
Rating: NEMA 4x, IP66

Zero and Span Adjustments:

± 10% of range

Mounting:

Direct connection

Electrical Ratings:

Intrinsically safe for use in
Class 1, Div. 1, Groups A-D; CE Compliant
(EMC Industrial Locations)

Standards:

Designed and manufactured to sound engineering practices in accordance with Article 3.3 of the PED 97/23/EC

Autoclaveable Specifications (Option)

Process Connections:

1.5" Tri-clamp or CPM only

Maximum Autoclave Temperature:

124°C (255°F)

Maximum Autoclave Cycle Time:

1 hour at Max Temp

Number of Autoclave Cycles:

Warranted for 250 cycles minimum

Cabling:

Quick Disconnect Receptacle(QDR) w/ Field Wiring Connector(FWC) included**

* Specifications are subject to change without notice

** FWC and attached cabling must be disconnected during autoclave cycles; QDR must be left in place during autoclave cycles. Refer to Application Bulletin DOC1127.

Complete Product Ordering Matrix

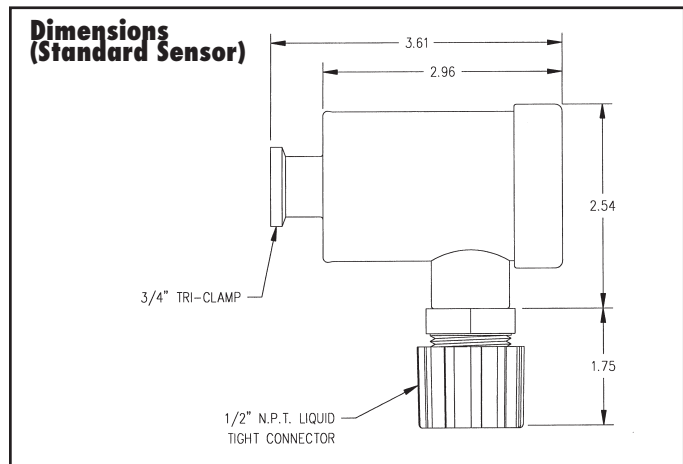
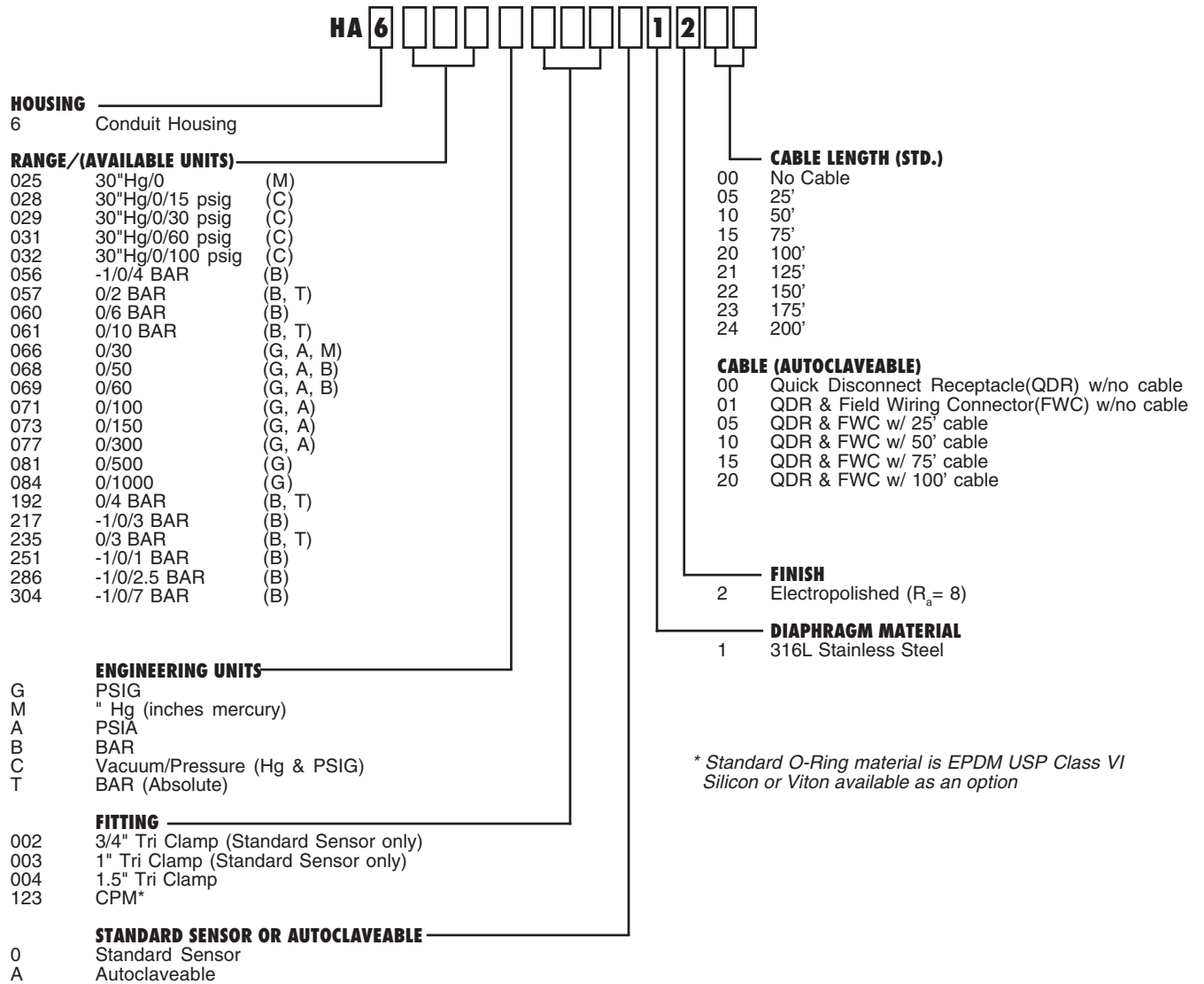

Form#5003 © 12/97
Revised: 1/05
Supersedes: 9/04