

DUAL-LINE TEMPERATURE METER

ProVu • Model PD7000



PROVU
SERIES



- J, K, T, E, R, S, B, N, C Thermocouples
- 100 or 1000 Ω Platinum, 10 Ω Copper, 120 Ω Nickel RTDs
- 1° or 0.1° Resolution
- Averages up to 10 RTD Sensors
- Automatic Cold Junction Compensation
- NEMA 4X, IP65 Front
- Universal 85-265 VAC or 12/24 VDC Input Power
- Large Dual-Line 6-Character Display, 0.60" & 0.46"
- Programmable Displays & Function Keys
- Sunlight Readable Display
- 2 or 4 Relays + Isolated 4-20 mA Output Options
- External 4-Relay & Digital I/O Expansion Modules
- RS-232, RS-422/485 Serial Communication Options
- Modbus® RTU Protocol Standard
- -20 to 65°C Operating Temperature Range

INTRODUCTION

The ProVu meter boasts specifications and functionality that clearly makes it one of the most advanced temperature meters available. Its dual-line 6-character display, function keys, and optional expansion modules are only a few of the features you will find on the ProVu.

Versatile

The PD7000 accepts many more thermocouple types and RTDs than earlier models. It can be configured to have either a 1 or 0.1 degree display resolution on any type of sensor input. The second line of display makes configuration simpler. The display itself is quite configurable. There are many relay functions for up to 8 relays; including an Interlock Relay function. The 4-20 mA output can represent up to 11 different parameters/variables. This makes the PD7000 one of the most versatile meters on the market.

FRONT PANEL DISPLAY

Precise, Accurate, and More Informative

ProVu's large 0.6" main display provides an accurate and precise 4 or 5-digit view of your temperature measurement.

Configurable

The main display can be programmed to indicate current temperature, maximum or minimum temperature, alternating maximum/minimum temperatures, or one of eight alarm set points. The secondary display can also be configured to display engineering units, setpoints, user defined legends, or simply turned off.



Function Keys

There are three function keys available to the user. These keys can be programmed to trigger certain events (i.e. acknowledge alarms, reset max and/or min, disable/enable output relays, or hold current relay states), provide direct menu access points, and more.

Easy to Use

The user friendly dual-line display makes the ProVu easy to set up & configure. Setup & configuration is done via the front panel. Three levels of password protection help maintain the reliability of the configuration.



Rugged

A unique front panel design makes the ProVu nearly impenetrable in typical applications. Here, the ProVu easily survives a direct hit on the display from a heavy 2" solid stainless steel ball dropped from eight feet.

Feature Rich and Flexible



Large
0.6" Digits

(Actual Size)

Rugged Front

Dual-Line
6-Character
Display

User Configurable
Display

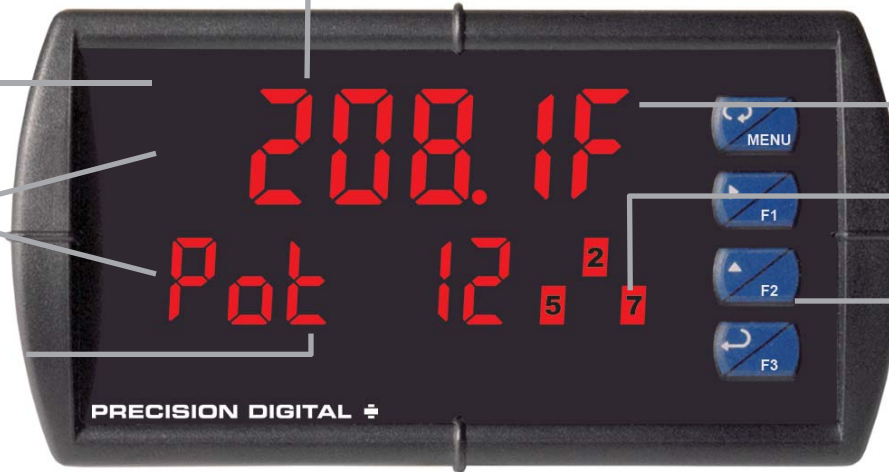

Temperature
Units

Alarm
Status Indicators

Programmable
Function Keys

METERVIEW PRO

MeterView Pro can be used to configure, monitor, any ProVu model from a PC. Save/recall configurations to/from PC.



Free download at predig.com

FIELD EXPANSION MODULES

Add functionality to the ProVu in the field with easy-to-install external expansion modules. Add RS-232 or RS-422/485 communications, I/O modules (up to 2), or 4-relay expansion module. The menu items for these modules do not appear until the module is connected, simplifying the basic menu. Relay and digital I/O modules are shown above with optional DIN rail mounting kit, P/N PDA1002.



Communications Module (Modbus®)

Serial communications on the ProVu can be added anytime with external RS-232 or RS-422/485 communication adapters. Modbus® protocol is standard on all ProVu's at no extra charge.

I/O Expansion Module

Four digital inputs and four digital outputs are available per expansion module. The ProVu meter will accept two of these modules. External digital inputs can function similarly to the front panel function keys. They can be configured to trigger certain events (i.e. acknowledge/reset alarms, reset max and/or min values, disable/enable all output relays, and hold current relay states), provide direct menu access point, or mimic front panel keys.

Digital outputs can be used to remotely monitor ProVu's alarm relay output states, or the states of a variety of actions and functions executed by the meter.

Relay Expansion Module

An external module containing four 3 amp Form A (SPST) relays can be added to the ProVu at anytime. Removable screw terminal blocks accept 12 to 22 AWG wire.



METER COPY

The Copy feature is used to copy (or clone) all the settings from one ProVu to other ProVu meters in about 20 seconds! The Copy function is a standard feature on all meters. It does not require a communications adapter, only an optional cable assembly, P/N PDA1200. See the ordering information for complete details.



OUTPUTS

Relay Outputs

The PROVU has up to four 3 A Form C relays (SPDT), giving you more fail-safe options upon power loss. Set ON and OFF time delays when needed. Up to eight front panel indicators show alarm and/or relay state. Can be configured for 0-100% deadband.

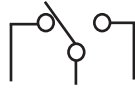

Relay Operation/Configuration

There are powerful relay functions that can be configured in the PROVU meter, including:

- Automatic reset only (non-latching)
- Automatic + manual reset at any time (non-latching)
- Latching (manual reset only)
- Latching with clear (manual reset only after alarm condition has cleared)
- User selectable fail-safe operation
- Relay action upon sensor break
- Time delay (on and off), independent for each relay
- Manual control mode

Front panel button or digital input may be assigned to acknowledge relays programmed for manual reset.

Interlock Relay(s)

This feature allows a process to use a very low voltage input signal(s) or simple switch contact(s) to force closed N/O contacts of assigned internal relay(s) to “open” when an external switch contact (or any part of the circuit) is opened. One input can be used in series with a number of interlock switches, or up to eight inputs can be required to force-on one (or more) internal interlock relays. Please see Application Note AN-1007 on our website for more information. Requires PDA1044 Digital I/O module.

Analog Output

The isolated analog retransmission signal can be configured to represent the measured temperature, maximum or minimum temperature, or any of the eight relay set points. While the output is nominally 4-20 mA, the signal will accurately accommodate under- and over-ranges from 1 to 23 mA. A power supply (24 V @ 40 mA) is standard with the 4-20 mA output option.

CONNECTIONS

- Form C (SPDT) relays
- Isolated supply available even on 12/24 VDC input power models
- Removable terminal blocks
- 2 or 4 relays + isolated 4-20 mA output option

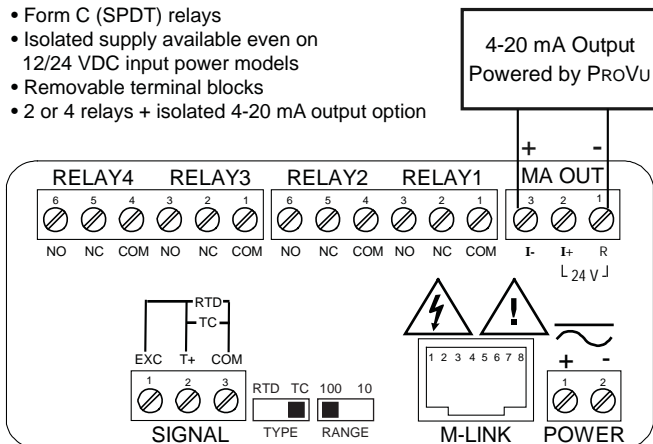

- Universal 85-265 VAC or 12/24 VDC input power
- Thermocouple or RTD inputs
- M-Link for adding expansion modules

SPECIFICATIONS

Except where noted all specifications apply to operation at +25°C.

General

Display: Main display: 0.60" (15 mm) high red LEDs; second display: 0.46" (12 mm) high red LEDs. Both displays have six-characters with leading zero blanking. Temperature value is four or five-digit F/C, based on configuration.

Resolution: 1° (up to four digits) or 0.1° (up to five digits)

Display Intensity: Eight intensity levels

Display Update Rate: 5/second (200 ms)

Front Panel: NEMA 4X, IP65

Programming Methods: Four front panel buttons, digital inputs, PC and MeterView Pro S/W, Modbus registers, or cloning using Copy function.

Noise filter: Programmable from 2 to 199 (0 will disable filter)

Filter Bypass: Programmable from 0.1 to 99.9% of span

Recalibration: Calibrated at the factory. Recalibration is recommended at least every 12 months.

Max/Min Display: Max / min temperature readings are stored until reset by the user or until power to the meter is turned off.

Password: Three programmable passwords restrict modification of programmed settings. Pass 1: Allows use of the F1–F3 function keys.

Pass 2: Allows use of the F1–F3 function keys and changing the set/reset points. Pass 3: Restricts all programming and F1–F3 keys.

Non-Volatile Memory: All programmed settings are stored in non-volatile memory for a minimum of ten years if power is lost.

Power Options: 85-265 VAC 50/60 Hz, 90-265 VDC 20 W max, or jumper selectable 12/24 VDC ±10%, 15 W max.

Fuse: Required external fuse: UL Recognized, 5 A max, slow blow; up to 6 meters may share one 5 A fuse.

Normal Mode Rejection: Greater than 65 dB at 50/60 Hz

Isolation: 4 kV input/output-to-power line. 500 V input-to-output

Environmental: Operating temperature range: -20 to 65°C. Storage temperature range: -40 to 85°C. Relative humidity: 0 to 90% non-condensing.

Connections: Removable screw terminal blocks accept 12 to 22 AWG wire, RJ45 for external relays, digital I/O, and serial communication adapters.

Enclosure: 1/8 DIN, high impact plastic, UL 94V-0, color: black

Mounting: 1/8 DIN panel cutout required: 3.622" x 1.772"

(92 mm x 45 mm). Two panel mounting bracket assemblies are provided.

Tightening Torque: Screw terminal connectors: 5 lb-in (0.56 Nm)

Overall Dimensions: 4.68" x 2.45" x 5.64"

(119 mm x 62 mm x 143 mm) (W x H x D)

Weight: 9.5 oz (269 g)

UL File Number: UL & c-UL Listed. E160849; 508 Industrial Control Equipment.

Warranty: 3 years parts & labor

Temperature Input

Inputs: Thermocouple J, K, T, E, R, S, B, N, C; RTD 100 Ω platinum (0.00385 & 0.00392 curves), 10 Ω copper, 120 Ω nickel, 1000 Ω platinum

Input Impedance: Greater than 100 kΩ

Offset Adjust: User programmable offset adjust ±199.9 degrees

Temperature Drift: ±2°C maximum from 0 to 65°C ambient temperature; ±4°C maximum from -20 to 0°C ambient temperature

Sensor Break: Display flashes “Open”, relays can be programmed to go “On”, “Off”, or to “Ignore” (detected as an upscale condition).

Averaging: Up to 10 RTDs connected in parallel can be averaged.

Accuracy & Range: See table below.

Type	Range (°F)	Range (°C)	Accuracy
J	-200° to 2000°	-129° to 1093°	±1°C
K	-200° to 2400°	-129° to 1316°	±1°C
T	-200° to 752°	-129° to 400°	±1°C
E	-200° to 1800°	-129° to 982°	±1°C
R	-50° to 3000°	-46° to 1649°	±2°C
S	-50° to 3000°	-46° to 1649°	±2°C
B	752° to 3300°	400° to 1816°	±2°C
N	-100° to 2300°	-73° to 1260°	±2°C
C	32° to 4100°	0° to 2260°	±2°C
10 Ω	-328° to 500°	-200° to 260°	±0.1°C
100 Ω	-328° to 1562°	-200° to 850°	±0.4°C
120 Ω	-110° to 500°	-79° to 260°	±0.1°C
1000 Ω	-328° to 900°	-200° to 482°	±0.4°C

Relays

Rating: 2 or 4 SPDT (Form C) internal and/or 4 SPST (Form A) external; rated 3 A @ 30 VDC and 125/250 VAC resistive load; 1/14 HP (≈ 50 watts) @ 125/250 VAC for inductive loads such as contactors, solenoids, etc.

Noise Suppression: Noise suppression is recommended for each relay contact switching inductive loads.

Deadband: 0-100% of span, user programmable

High or Low Alarm: User may program any alarm for high or low trip point. Unused alarm LEDs and relays may be disabled (turned off).

Relay Operation: automatic (non-latching) or latching (requires manual acknowledgement)

Time Delay: 0 to 999.9 seconds, on & off relay time delays. Programmable and independent for each relay.

Fail-Safe Operation: Programmable and independent for each relay. *Note: Relay coil is energized in non-alarm condition. In case of power failure, relay will go to alarm state.*

Auto Initialization: When power is applied to the meter, relays will reflect the state of the input to the meter.

Isolated 4-20 mA Transmitter Output

Output Source: measured temperature, maximum temperature, minimum temperature, set points 1-8, or manual control mode

Scaling Range: 1.000 to 23.000 mA for any display range

Calibration: Factory calibrated 4-20 mA output

Accuracy: ± 0.1% of span ± 0.004 mA

Temperature Drift: 0.005% of calibrated span/°C max from 0 to 65°C ambient, 0.01% of calibrated span/°C max from -20 to 0°C ambient

Note: Analog output drift is separate from input drift.

Isolated Transmitter Power Supply: Terminals I+ & R: 24 VDC ± 10% @ 40 mA maximum, may be used to power the 4-20 mA output or other devices. Present on both AC & DC powered units.

External Loop Power Supply: 35 VDC maximum

Output Loop Resistance:

Power supply	Minimum	Maximum
24 VDC	10 Ω	700 Ω
35 VDC (external)	100 Ω	1200 Ω

Serial Communications

Protocol: Modbus® RTU

Meter Address/Slave ID: 1 - 247

Baud Rate: 300 - 19,200 bps

Transmit Time Delay: Programmable between 0 and 199 ms or transmitter always on for RS-422 communication

Data: 8 bit (1 start bit, 1 or 2 stop bits)

Parity: Even, odd, or none with 1 or 2 stop bits

Byte-to-Byte Timeout: 0.01 - 2.54 second

Digital I/O Expansion Module

Channels: 4 digital inputs & 4 digital outputs per module

System: Up to 2 modules for a total of 8 inputs & 8 outputs

Digital Input Logic: High: 3 to 5 VDC Low: 0 to 1.25 VDC

Digital Output Logic: High: 4.75 to 5 VDC Low: 0 to 0.4 VDC

Source Current: 10 mA maximum

Sink Current: 1.5 mA minimum

+5 V Terminal: To be used as pull-up for digital inputs only.

4-Relay Expansion Module

Relays: Four Form A (SPST) rated 3 A @ 30 VDC and 125/250 VAC resistive load; 1/14 HP (≈ 50 watts) @ 125/250 VAC for inductive loads.

Disclaimer

The information contained in this document is subject to change without notice. Precision Digital Corporation makes no representations or warranties with respect to the contents hereof, and specifically disclaims any implied warranties of merchantability or fitness for a particular purpose.

©2010 Precision Digital Corporation. All rights reserved.

MOUNTING DIMENSIONS

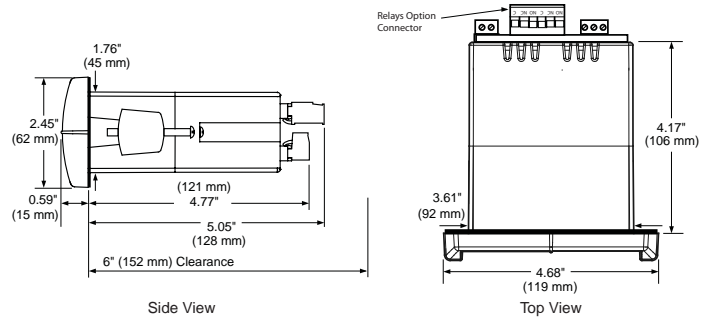

Notes:

1. Panel cutout required: 1.772" x 3.622" (45mm x 92mm)
2. Panel thickness: 0.040 - 0.250" (1.0mm - 6.4mm)
3. Mounting brackets lock in place for easy mounting
4. Clearance: Allow 6" (152 mm) behind the panel

ORDERING INFORMATION

ProVu • Model PD7000 Temperature Meter		
85-265 VAC Model	12/24 VDC Model	Options Installed
PD7000-6R0	PD7000-7R0	None
PD7000-6R2	PD7000-7R2	2 Relays
PD7000-6R3	PD7000-7R3	4-20 mA Output
PD7000-6R4	PD7000-7R4	4 Relays
PD7000-6R5	PD7000-7R5	2 Relays & 4-20 mA Output
PD7000-6R7	PD7000-7R7	4 Relays & 4-20 mA Output

Accessories	
Model	Description
PDA1002	DIN Rail Mounting Kit for Two Expansion Modules
PDA1004	4-Relay Expansion Module
PDA1044	4 Digital Inputs & 4 Digital Outputs Module
PDA1200	Meter Copy Cable
PDA1232	RS-232 Serial Adapter
PDA1485	RS-422/485 Serial Adapter
PDA7485-I	RS-232 to RS-422/485 Isolated Converter
PDA7485-N	RS-232 to RS-422/485 Non-Isolated Converter
PDA8232-N	USB to RS-232 Non-Isolated Converter
PDA8485-I	USB to RS-422/485 Isolated Converter
PDA8485-N	USB to RS-422/485 Non-Isolated Converter
PDX6901	Suppressor (snubber): 0.01 μF/470 Ω, 250 VAC
PDA2811	NEMA 4X Enclosure for 1 Meter
PDA2812	NEMA 4X Enclosure for 2 Meters

See www.predig.com for additional enclosures.

Your Local Distributor is:

LDS7000_AX13 04/10