

**MODEL QTS-8000 SERIES
NON-INTRUSIVE CALIBRATION
INDUSTRIAL TRANSMITTER/SENSOR**

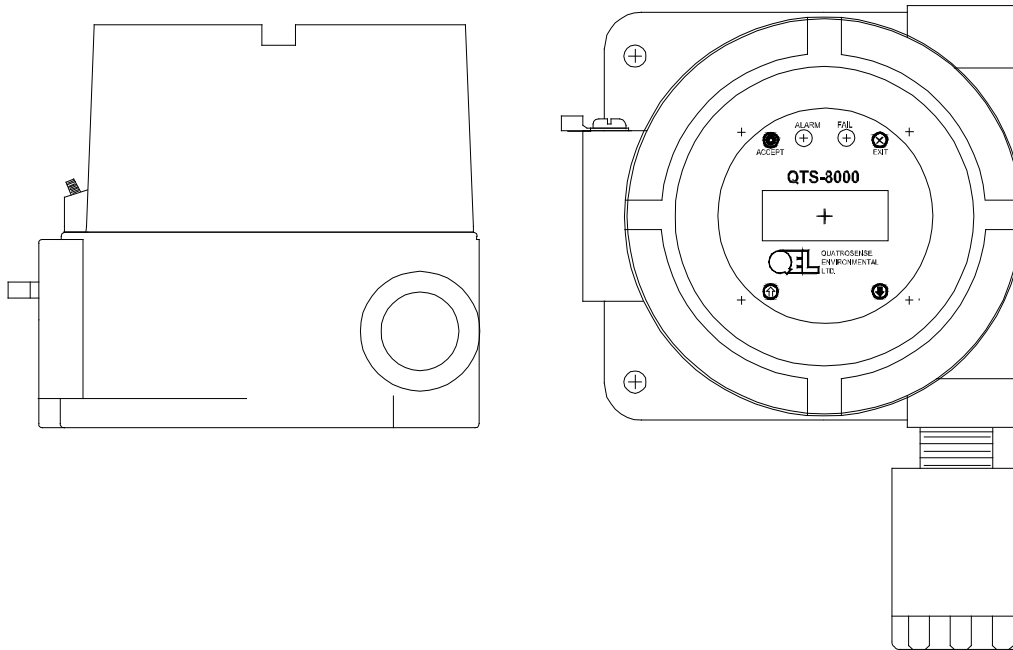

**INSTALLATION
OPERATION AND MAINTENANCE
MANUAL**

QUATROSENSE ENVIRONMENTAL LTD.
5935 OTTAWA STREET, PO BOX 749 RICHMOND, ONTARIO CANADA K0A 2Z0
PHONE: (613) 838-4005 FAX: (613) 838-4018
Web: www.QELsafety.com Email: QEL@QELsafety.com

QTS-8000 Configuration & Calibration

Model _____ S/N _____

Gas _____ Range _____

J Coefficient (Combustibles Catalytic) _____

Circuit Card Options:

Electrochemical _____

Combustible (Catalytic) _____

Combustible (Infrared) _____

Extended Feature/Relay _____

Hardware:

Battery enabled _____

Sensor Type _____

Settings:

Warning:

Actuation _____

De-Actuate _____

Delay on Actuate _____

Delay on De-Actuate _____

Latching _____

Hi/Lo _____

Alarm:

Actuation _____

De-Actuate _____

Delay on Actuate _____

Delay on De-Actuate _____

Latching _____

Hi/Lo _____

Communication/Signal

4 - 20 mA _____

0 - 10 V _____

Modbus RTU _____

Opto22 _____

Baud Rate _____

Address _____

WARRANTY STATEMENT

The information contained in this manual is based upon data considered accurate; however, no warranty is expressed or implied regarding the accuracy of this data. All QEL equipment is warranted against defects in material and workmanship for a period of two years from date of shipment with the following exceptions:

Electrochemical Sensors (Toxic)	Six Months
Catalytic Sensors (Combustible)	One Year

During the warranty period we will repair or replace, at our discretion, any components or complete units that prove, in our opinion, to be defective. We are not liable for consequential or incidental damage to auxiliary interfaced equipment.

A returned material authorization number should be obtained from the factory prior to returning any goods. All return shipments must be shipped freight prepaid and a copy of the maintenance records should accompany the unit concerned.

Warranty should be considered F.O.B. the factory. Labour and travel time are chargeable for any field site visits required for warranty work.

LIMITED LIABILITY

All QEL systems shall be installed by a qualified technician/electrician and maintained in strict accordance with data provided for individual systems in the form of installation/maintenance manuals. QEL assumes no responsibility for improper installation, maintenance, etc., and stresses the importance of reading all manuals. QEL shall not be responsible for any liability arising from auxiliary interfaced equipment nor any damage resulting from the installation or operation of this equipment.

QEL's total liability is contained as above with no other liability expressed or implied as the purchaser is entirely responsible for installation and maintenance of systems.

This warranty is in lieu of all other warranties, expressed or implied, and no representative or person is authorized to represent or assume for QEL any liability in connection with the sales of our products other than that set forth herein.

NOTE: Due to on-going product development, QEL reserves the right to change specifications without notice and will assume no responsibility for any costs as a result of modifications.

For further information or assistance, contact:

QUATROSENSE ENVIRONMENTAL LTD.

5935 Ottawa Street, PO Box 749

Richmond, Ontario

K0A 2Z0

Tel: (613) 838-4005

Fax: (613) 838-4018

Email: QEL@QELsafety.com

Web: www.QELsafety.com

Table of Contents

1. General specifications

1. GENERAL SPECIFICATIONS	1
1.1 SIZE	1
1.2 INPUT POWER	1
1.3 FUSE	1
1.4 SENSOR	1
1.5 RESPONSE TIME	1
1.6 SIGNALS	1
1.7 DATA COMMUNICATION	1
1.8 KEYPAD	1
1.9 REMOTE ACK	1
1.10 RELAY (EXTENDED FEATURE OPTION)	1
1.11 STANDARD RANGES	2
1.12 ENCLOSURE	2
1.13 CALIBRATION	2
1.14 ACCURACY	2
1.15 REPEATABILITY	2
1.16 SENSOR EXPECTED LIFE	3
1.17 TEMPERATURE	3
1.18 HUMIDITY	3
1.19 PRESSURE	3
1.20 LCD DISPLAY	3
1.21 LED INDICATORS	3
1.22 WIRES	3
2. THEORY OF OPERATION:	4
2.1 OPERATION MODES OF THE TRANSMITTER:	4
2.2 CONTROL FEATURES	4
2.3 HARDWARE MONITORING POINTS	4
2.4 SELF CHECK AND WATCHDOG TIMER	5
3. ELECTROCHEMICAL SENSOR ELEMENTS	6
4. COMBUSTIBLE GAS SENSORS: CATALYTIC BEAD TYPE	7
4.1 GLOSSARY:	7
4.2 CALIBRATION FOR COMBUSTIBLE GASES OTHER THAN METHANE:	7
4.2.1 Configuration	8
4.2.2 Calibration	8
4.2.3 Commonly Used Values	8
4.2.4 Special Gases	8
4.2.5 Fault Detection and Autozero	8
4.3 LATCHING RELAYS	9
4.4 SENSOR POISONS AND FILTERING	9
4.4.1 Poison Resistant Sensors	9
4.4.2 Filters	10
4.5 OPERATION PROCEDURE:	10
5. COMBUSTIBLE GAS SENSORS: INFRARED SMART SENSOR TYPE	11
5.1 INFRARED SENSOR	11

5.2	SMART INFRARED SENSOR	11
5.3	REMOTE SMART INFRARED SENSOR.....	11
5.4	RELATIVE SENSITIVITY OF COMBUSTIBLE GASES/VAPORS	11
6.	CONFIGURATION.....	12
6.1	CATALYTIC SENSOR	12
6.2	ELECTROCHEMICAL SENSOR	13
6.3	SPAN SETTING	15
7.	OTHER CONFIGURATION ITEMS.....	15
7.1	PLUGGABLE TERMINAL BLOCKS	15
7.2	FUSES.....	15
7.3	SIGNAL SELECTION	15
7.4	SETPOINT	15
7.5	BACKUP BATTERY FOR CALENDAR AND REAL-TIME CLOCK	15
7.6	DIGITAL COMMUNICATIONS	16
7.6.1	<i>Digital Addressing</i>	16
7.6.2	<i>Protocol selection</i>	16
7.6.3	<i>RS-485 Configuration</i>	16
8.	GAS CALIBRATION.....	17
8.1	CALIBRATION JACKS AND EQUIPMENT	17
8.2	CALIBRATION SELF CHECKS.....	17
8.3	CALIBRATION FOR COMBUSTIBLE GAS TRANSMITTER(CATALYTIC)	18
8.3.1	<i>Zero calibration</i>	18
8.3.2	<i>Span calibration</i>	18
8.4	CALIBRATION FOR TOXIC GAS TRANSMITTER.....	18
8.4.1	<i>Zero calibration</i>	18
8.4.2	<i>Span calibration</i>	19
8.5	CALIBRATION FOR COMBUSTIBLE GAS TRANSMITTER (IR).....	19
8.5.1	<i>Zero calibration</i>	19
8.5.2	<i>Span calibration</i>	19
8.6	ZERO AND SPAN CHECKING	19
9.	MMI OPERATION	20
9.1	MMI OPERATION.....	20
9.1.1	<i>The keypads function:</i>	20
9.1.2	<i>The step mode and fast mode:</i>	20
9.1.3	<i>Password:</i>	20
9.2	MENU DEMO.....	21
10.	OPERATING INSPECTION AND MAINTENANCE	26
10.1	OPERATION INSPECTION.....	26
10.2	MAINTENANCE.....	26

1. General Specifications

1.1 Size

- 5.25" x 7.75" x 5.00" (133 mm x 197 mm x 127 mm)

1.2 Input power

- 24 VDC nominal (range 18 to 30 VDC)
- 24 VAC nominal (range 15 to 24VAC), extended feature option only

1.3 Fuse

- 1.0 Amp socketed pico fuse

1.4 Sensor

- Electrochemical or Catalytic sensor or Infrared Smart Sensor (IR)

1.5 Response time

- Electrochemical sensor: Typical less than 60 seconds for 90% response to a step change
- Catalytic sensor: < 15 seconds for 90% response to a step change
- IR smart sensor: < 36 seconds for 90% response to a step change

1.6 Signals

- 4 - 20 mA current signal, Max. load without HART multi-drop connection:
 - 700 Ohms at 24VDC,
 - 500 Ohms at 20 VDC
- Optional: 0 - 10 VDC voltage signal 1K Ohms output impedance, 5K Ohms Min. load resistor

Note: 4 - 20 mA and 0 - 10V signals can't be used at the same time

1.7 Data communication

- MODBUS protocol over RS-485 (extended feature option)*
- OPTO22 protocol over RS-485 (extended feature option)*

1.8 Keypad

- 4 magnetic sensors

1.9 Remote ACK

- Reset latched relays and LED indicators, termination supplied for receipt of remote signal (24 VDC or 24 VAC) (extended feature option)

1.10 RELAY (Extended Feature Option)

- Relay Contacts: 2 user-programmable SPDT relays, 115 VAC, 30 VDC, 1 amp

1.11 Standard ranges

- For toxic gas:

Gas	Model Code	Factory Standard Span	Allowed Span Ranges	Temperature (C)	Temperature (F)
H ₂ S	81110X	0 - 25 ppm	10 - 100 ppm	-40° - +50°C	-40° - +122°F
HCN	81115X	0 - 20 ppm	8 - 80 ppm	-20° - +50°C	-4° - +122°F
Cl ₂	81120X	0 - 3 ppm	1.5 - 14 ppm	-20° - +50°C	-4° - +122°F
ClO ₂	81123X	0 - 1 ppm	0.5 - 5 ppm	-20° - +50°C	-4° - +122°F
HCL	81125X	0 - 10 ppm	4 - 35 ppm	-20° - +50°C	-4° - +122°F
O ₂	81130X	0% - 25% VOL	3% - 30% VOL	-20° - +50°C	-4° - +122°F
SO ₂	81140X	0 - 6 ppm	2 - 20 ppm	-20° - +50°C	-4° - +122°F
NO ₂	81150X	0 - 6 ppm	10 - 12 ppm	-20° - +50°C	-4° - +122°F
CO	81160X	0 - 250 ppm	40 - 400 ppm	-20° - +50°C	-4° - +122°F
NO	81190X	0 - 100 ppm	30 - 300 ppm	-20° - +50°C	-4° - +122°F
H ₂	81211X	0 - 2000 ppm	50 - 5000 ppm	-20° - +50°C	-4° - +122°F
NH ₃	81220X	0 - 50 ppm	20 - 210 ppm	-25° - +30°C	-13° - +86°F
NH ₃	81221X	0 - 50 ppm	15 - 150 ppm	-25° - +30°C	-13° - +86°F
C ₂ H ₄ O	81230X	0 - 10 ppm	1 - 10 ppm	-20° - +50°C	-4° - +122°F
O ₃	81240X	0 - 3 ppm	0.2 - 3 ppm	-20° - +50°C	-4° - +122°F

Table 1 Standard Factory Range Settings

- For combustible Gas:
 - 0 - 100% LEL (Catalytic).
 - 0 - 100%LEL (IR)
 - 0 - 100% Volume (IR)

Conversion factors internally allow cross reference for different gases

1.12 Enclosure

- Ex. proof, CL I, Div. 1, Group B, C, D.

1.13 Calibration

- Initial internal adjustments/setting depending on sensor and range, Non-Intrusive calibration with magnetic tool supplied

1.14 Accuracy

- < ± 1% of span

1.15 Repeatability

- ±1%

1.16 Sensor expected Life

- Typical 2 to 3 years; oxygen 1 to 2 years
- MTBF (IR Smart Sensor) > 5 years

1.17 Temperature

- Transmitter: -40° to +50° C (-40° to 122° F)
- Electrochemical Sensor: see Table 1
- Catalytic combustibles sensors - 40° to +50° C (-40° to 122° F)
- IR Smart Sensor - 40° to +75° C (-40° to 167° F)

1.18 Humidity

- Sensor: 15 to 90% RH, non-condensing
- Transmitter: 0 - 99% non-condensing

1.19 Pressure

- Atmospheric \pm 10%

1.20 LCD display

- 2 line x 8 character alpha-numeric LCD display with backlight (user configurable)

1.21 LED Indicators

- 2 LED indicators
 - Gas Status: warning (yellow), alarm (red)
 - Fault Status (red)

1.22 Wires

- AWG 14 - 24(ϕ 0.51mm to ϕ 1.6mm)
- RS-485 communication: 120 Ω , balanced, twisted pair (e.g. Belden 9841 or equivalent)

2. Theory of Operation:

QTS-8000 Series Non-intrusive calibration transmitter/sensor is designed for use in the hazardous industrial field. The transmitter is microprocessor based, and has a number of intelligent features and options. It is structured for non-intrusive calibration using a magnetic tool. The basic unit offers only analog signaling and alphanumeric display. It consists of two basic circuit cards (Display card and Sensor card). There are three types of sensor cards: Electrochemical Sensor card and Catalytic Sensor card and IR interface card for use with the respective types of sensors.

There is an optional Extended Feature card which contains 2 relays, RS-485 interface and 24VDC/VAC power supply support.

Two open 3/4" NPT conduit entries are supplied for wiring.

2.1 Operation Modes of the transmitter:

The operation mode of the transmitter is divided into *on-line* and *off-line*.

In *on-line* mode, the transmitter measures the concentration of the gas chosen by the sensor and gas in the configuration menu and detects the warning and alarm level set by the setpoints in the setpoint menu.

In *off-line* mode, the transmitter does not deal with any measurement or actuation. Off-line mode is entered to set configuration, warning and alarm setpoints, password, time/date. Gas calibration and the output signal (4 - 20 mA) accuracy check can be completed. In off-line mode, the output signal is fixed at 4.00 mA except for the accuracy check.

2.2 Control Features

When initial hardware configuration has been completed, all calibration features are software mediated. All calibration functions and all other configuration items such as relay setpoints, baud rates, etc., are accessed through a magnetic "keypad" consisting of 4 magnetically sensitive points. These are indicated as Accept, Exit and \uparrow and \downarrow . See Section 9 **MMI Operation** for details.

2.3 Hardware Monitoring Points

To verify and adjust the actual signals (4 - 20mA or 0 - 10V), there are four test points that can accept standard multi-meter probe tips. Note that there are two options for monitoring the 4 - 20mA output. If one probe is at Cal 4 and the other is at Cal 2, the signal is interrupted to the monitor. If one probe is at Cal 4 and the other at Cal 3, then the 4 - 20mA signal is monitored but not interrupted.

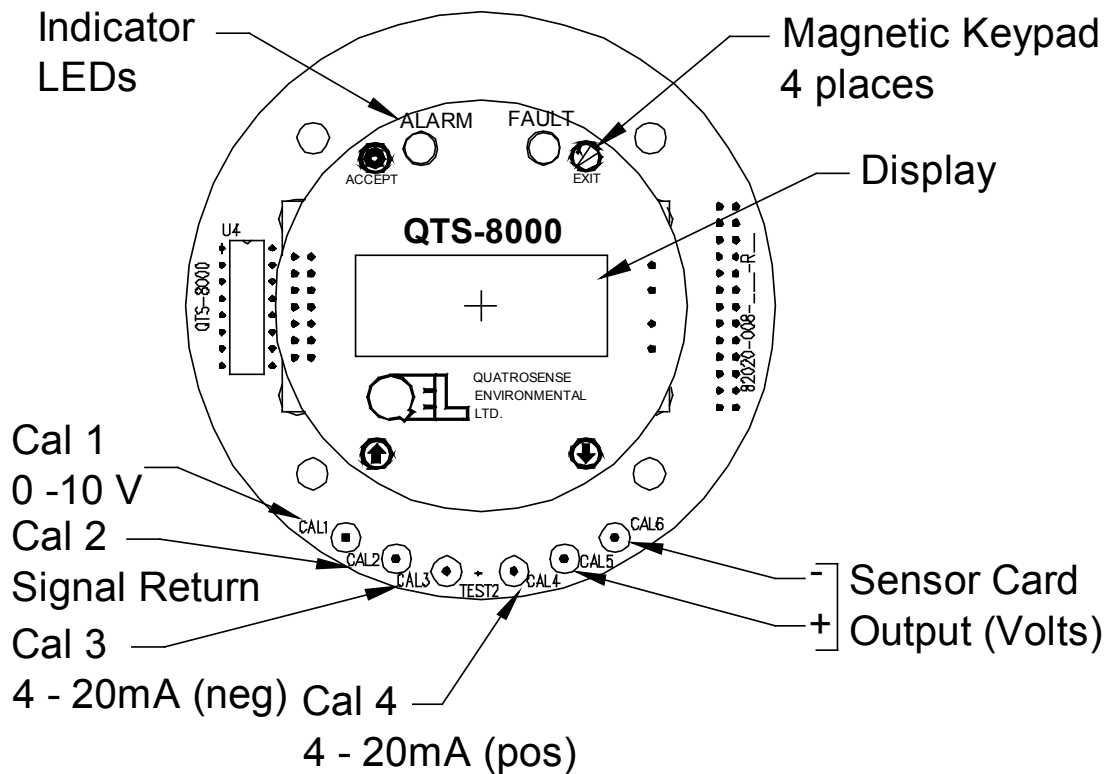

Figure 1 Display Card Features

2.4 Self Check and Watchdog Timer

The microprocessor maintains a number of regular internal functional checks approx every 100 ms. If it detects any of these conditions, it will display an error message. None of these faults is field repairable. The microprocessor maintains an on board watchdog timer to check for a lost or looping condition. The microprocessor will automatically reset.

Fault messages are

- FAILURE/EEPROM1 EEPROM 1 read/write fault
- FAILURE/EEPROM2 EEPROM 2 read/write fault
- FAILURE/ADC/+5Vrf A/D converter or reference voltage failure
- FAILURE/Signal Output signal (4-20mA or 0-10V) not within specification

3. Electrochemical Sensor Elements

The sensor series used for Toxic gas detection is a compact City Technology electrochemical sensor. These sensors are micro-fuel cells that are completely sealed so as to be maintenance free and stable for long periods. The measurement is a gas-in-liquid chemical reaction rather than a surface area measurement. With no surface area to coat, these sensors retain their sensitivity to gases such as H₂S even after prolonged exposure to clean air. With the exception of Ammonia (NH₃) and Oxygen the cells are not consumed or damaged by exposure to gas concentrations within their operating range.

The cell consists of a diffusion barrier, O-ring seal, electrolyte reservoir and three electrodes; Sensing, Counter, and Reference (see Fig. 2). The target gas enters the cell through a diffusion barrier. The chemical process of the measurement is one of oxidation where one molecule of the target gas is exchanged for one molecule of oxygen. The reaction drives the oxygen molecule to the Counter electrode, generating a DC micro-amp signal between the Sensing and Counter electrodes. This signal is linear to the volume concentration of the sensed gas rather than the partial pressure. These sensors will not respond to normal variations in atmospheric pressure.

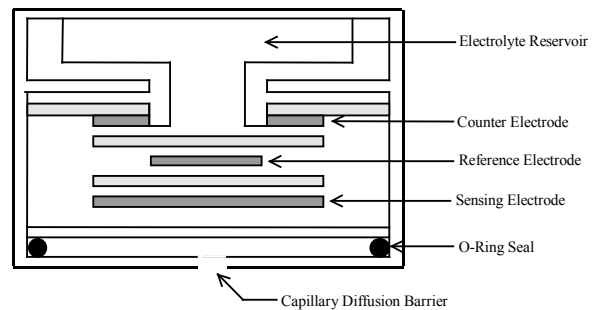

Figure 2 - Toxic Cell Construction
(Schematic Drawing)

In some cases, biasing is required to maintain a voltage differential between the Reference and Sensing electrodes in order to facilitate the necessary reaction in the cell. The transmitter electronics will provide the necessary bias voltage when configured for one of these sensor types. Most sensors produce a small amount of “baseline” current in clean air. This is adjusted out with software during calibration.

This oxidation at the electrodes causes wear, and limits the life of the sensor. Typical life for these sensors is two to three years in normal operation. This will vary somewhat from sensor to sensor, with some working life-times exceeding four years. This wear also changes the characteristics of the sensor, requiring regular re-calibration. It is recommended that these sensors be re-calibrated every three months or as necessary.

Some sensors have on-board filters to enhance gas specificity. In most cases these filters will last the life of the sensor, but in the presence of high concentrations of solvents or other gases, these filters may become exhausted. Consult factory for more information.

CAUTION Replacement sensor elements which are not bias types are shipped with a tiny spring of wire shorting the Sense and Reference Electrodes. This spring must be removed prior to installing the element to the sensor assembly.

4. Combustible Gas Sensors: Catalytic Bead Type

Catalytic bead gas sensors involve a tiny coil of platinum wire embedded in a ceramic bead incorporating a catalyst. Power is supplied to the bead to raise the temperature sufficiently high (~300° C) as to cause catalytic combustion of hydrocarbons in the presence of oxygen (air). The combustion of the gas produces heat, which raises the temperature of the bead causing a change in resistance.

To remove environmental effects due to ambient temperature, pressure, and gas thermal conductivity, a second bead is used, closely matched to the first except that it has been coated to be inert with respect to catalytic action. Operating the two in a Wheatstone bridge produces a stable and reliable signal, largely linear with respect to % of the lower explosive limit (LEL).

4.1 Glossary:

LEL	Lower Explosive Limit. The lowest concentration of the gas, displacing air at standard temperatures and pressures which will support a flame.
LFL	Lower Flammable Limit. The LEL. More correct usage.
UEL	Upper Explosive Limit. The highest concentration of the gas, displacing air at standard temperatures and pressures which will support a flame.
UFL	Upper Flammable Limit. The UEL. More correct usage.
Catalysis	Chemical reaction that proceeds due to the presence of another material which is not consumed in the reaction.
Flash Point	The lowest temperature at which a liquid evaporates sufficiently to produce an ignitable mixture in air.

4.2 Calibration for combustible gases other than methane:

An attractive feature of the catalytic sensor used in the transmitter is the almost universal response to LEL of hydrocarbons. Almost all the detectable gases produce a similar sensor output at LEL. Therefore, calibration gas other than the gas to be detected can be used for calibration. In the transmitter, coefficient **J** is used for the gases other than methane.

J is the inverse of the response of the sensor to the target gas relative to the response to % LEL methane (CH₄). **J** is then the change in amplifier gain required in either hardware or software.

4.2.1 Configuration

In the QTS-8000 there are two occasions for setting the **J value**. Initially in configuration one tells the QTS-8000 the measurement target gas or the **J value** for the target gas. This value is set in the OFFLINE-->CONFIG.-->SENSOR-->COMBUST menu. If the gas is methane, propane or hydrogen, no **J** setting is needed, the transmitter will take the default value automatically when the gas is chosen.

4.2.2 Calibration

You can use a different gas for calibration than the measurement target gas. Therefore when performing calibration the **J value** of the gas used is set in the OFFLINE-->CAL.-->CAL.GAS menu. If the gas is methane, propane or hydrogen, no **J** setting is needed, the transmitter will take the default value automatically when the gas is chosen.

4.2.3 Commonly Used Values

Gas		L.E.L. % volume	J
Methane	CH ₄	5.0	1.00
Propane	C ₃ H ₈	2.1	1.67
Ammonia	NH ₃	15	1.54
Acetylene	C ₂ H ₂	2.5	1.761
n-Butane	C ₄ H ₁₀	1.8	1.82
Hydrogen	H ₂	4.0	1.05
n-Hexane	C ₆ H ₁₄	1.02	2.22
Ethane	C ₂ H ₆	3.0	1.18
n-Pentane	C ₅ H ₁₂	1.4	2.00
Gasoline	Varies	1.3	2.50

The **J** value of some commonly used gases is as follows. Consult the factory for gases not covered.

NOTE: These values are theoretically expected values only. Actual values may vary. It is always best to calibrate using the target gas.

Table 2 Common Combustible Calibration Values

4.2.4 Special Gases

In certain cases, such as Ammonia detection and heavy hydrocarbon detection such as Kerosene, QEL will use a sensor which is optimized for those gases. In these cases, the sensor will have minimal response to methane because it runs at a temperature too low to ignite the methane. Therefore propane is the better calibration gas to use when using a different calibrating gas.

4.2.5 Fault Detection and Autozero

The microprocessor maintains continual checks on the condition of the catalytic sensor. It checks for dead sensor - internal open circuit.

The microprocessor also maintains a partial autozero function. If the reading slips slightly negative for about 2 hours, then that signal level will be reassigned as the new zero level.

4.3 Latching Relays

The operation of the catalytic bead mimics actual combustion characteristics. Therefore as the concentration of the target gas increases, and exceeds the LEL, the signal becomes non-linear, reacting less and less to increased concentrations. As concentrations exceed the Upper Explosive Limit (UEL) and combustion is not well supported; this will cause the signal to fall and approach clean air values.

Exposure to very high values will always produce a transitory strong response. Therefore the alarm setpoints will actuate. Setting the setpoints to latching enables the operator to be warned of a possible high level situation.

CAUTION It is possible to have very high concentrations of combustible gases, while maintaining a low reading. Most Electrical Codes require that relays be latching with operator acknowledge to account for this.

In the case of latching relays, they can be reset only after the gas concentration is below the setpoint. Reset can be done with the magnetic tool on the display. It can also be done with a remote momentary switch closure (See Installation Drawings).

4.4 Sensor Poisons and Filtering

Catalytic bead sensors used in these instruments are subject to certain poisoning effects from some gases. Some gas classes, notably silicones are permanent poisons: they coat the surface of the sensor, preventing the sensor from interacting with the hydrocarbon gases being measured. There is no "cure" for sensors poisoned with silicones.

There are other gases which have similar effects, but which are to some degree reversible. These are Chlorinated solvents, sulphur based products and some others. The symptoms are the same, in that the sensor becomes non-responsive; however, it is possible to "burn off" the coating by applying an "overdose" for instance, a short exposure to pure butane. Long term operation in clean air will also reverse the condition. The procedure is always slightly damaging to the sensor, so it should not be done indiscriminately, and the sensor should be recalibrated afterwards.

Poisoned sensors often show a rise in the Zero reading usually to a maximum of 10 % LEL CH₄ at the same time as showing a loss of responsivity.

In many instances QEL supplies a filter of activated charcoal cloth (see Figure 3), but this is only useful for those target gases which will not be absorbed by the filter e.g. Methane and Propane.

CAUTION The only way to determine whether a sensor is poisoned is to apply a test gas.

4.4.1 Poison Resistant Sensors

QEL uses improved catalytic bead sensors which are very resistant to poisoning of this sort; however, they are not proof against poisons and should be tested regularly.

4.4.2 Filters

QEL has instituted the use of poison filters of activated charcoal impregnated cloth. These supply good protection against most poisons; however, they are not proof against poisons and should be changed regularly in an area known to have poisons present. When installing be certain that the filter presses firmly up against the flame arrestor face.

Activated charcoal filters may not be used when the gas being tested is of a type which will be absorbed by the filter.

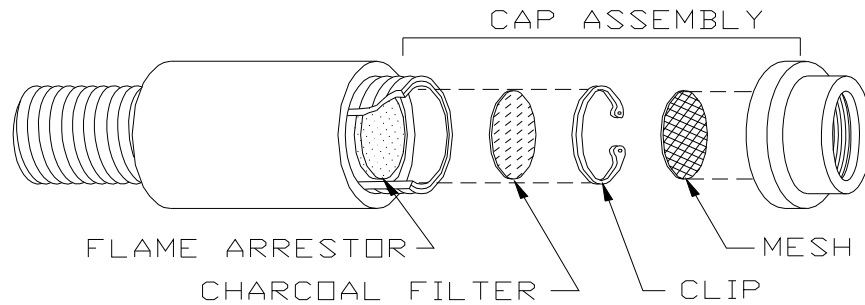

Figure 3 -Sensor Housing

4.5 Operation procedure:

When the power is turned on, the transmitter goes to the *on-line* mode directly. Configuration and setting must be completed before the transmitter can operate normally at the first use (see Section 9.1.3 **Password** for the way to enter the *off-line* mode from the *on-line* mode).

In the *off-line* mode, the transmitter must be configured first if it hasn't been configured. In the OFFLINE-->CONFIG menu, the proper sensor, span (for toxic gas only), J coefficient (for combustible gas only), communication address, output signal (4 - 20mA or 0 - 10V) and communication protocol can be chosen or set. The CONFIG menu is protected by configuration password, see 9.1.3 **password** for detail.

After configuration, the transmitter should be calibrated. In the OFFLINE-->CAL. menu, zero and span can be calibrated. The date of last calibration can be checked.

In the OFFLINE-->SETPOINT menu, the actuation level, de-actuation level, actuation delay, de-actuation delay, relay latched/not latched after actuation and actuated by concentration from low to high/from high to low can be set or selected.

In the OFFLINE menu, the transmitter will go back to the *on-line* mode when the EXIT key is touched.

5. Combustible Gas Sensors: Infrared Smart Sensor Type

5.1 Infrared Sensor

QEL combustible infrared sensors are designed to detect and monitor the presence of methane and broadband hydrocarbons using the non-dispersive infrared (NDIR) principles. Two detector channels are used with a reference for background compensation. Their construction is a stainless steel flame-proof enclosure with an integral stainless steel sinter for the safe entry of the gases being tested.

5.2 Smart Infrared Sensor

Smart Infrared Sensor is composed of Smart Sensor Main Board and Infrared Sensor. Smart sensor Main Board retains operating parameters and calibrating settings. Once the Smart Infrared Sensor is plugged into QTS-8000, the Smart Sensor Main Board automatically uploads current information to the control board in QTS-8000. This allows for quick and simple field installation and maintenance. Changing to a different type of gas sensor is accomplished by only changing the infrared sensor and Smart Sensor Main Board. The existing housing and wiring remains intact.

5.3 Remote Smart Infrared Sensor

Smart IR Sensor can be equipped with QTS-8000 locally or remotely. They have different Part Number for ordering. The max distance between QTS-8000 and Remote Smart IR Sensor is 500 meters.

5.4 Relative Sensitivity of Combustible Gases/Vapors

QTS-8000 IR transmitter is calibrated to Methane. The table shows the variation of the IR combustible sensor on exposure to applicable group combustible hydrocarbon gases and vapors at the same %LEL concentration. The figures are expressed relative to the methane signal (=100).

Gas/Vapor	Relative Sensitivity	Gas/Vapor	Relative Sensitivity
Methane	100	Ethylene	129
Propane	155	Butane	138
Pentane	123	Methanol	258
Benzene	76	Acetone	98
Butanol	276		

NOTE: This table is intended for guidance only. Always calibrate using the gas or vapor under investigation.

The results are intended for guidance only. **For a more accurate measurement calibrate using the gas or vapor under investigation.**

For IR sensors, use the specified gas to calibrate the system. IR sensors work very well in LOW or NO Oxygen Conditions. IR sensors monitor the molar concentration of the specific gases by a physical

method. No chemical reaction takes places inside the sensor.

Caution: IR systems should always be calibrated as soon as you install the system to compensate for any change in pressure.

6. Configuration

IR Smart Sensor doesn't need to be configured in the field. QTS-8000 would automatically recognize all kinds of IR Smart Sensor when powered up. For other sensors, the transmitter must be properly configured by DIP-switch, jumpers and in the CONFIG menu.

For configuration, **SENSOR MUST BE SELECTED FIRST.**

6.1 Catalytic Sensor

Catalytic sensor is configured in the OFFLINE--> CONFIG.--> SENSOR-> COMBUST menu only, the gas to be detected can be selected and the **J** coefficient can be set in the menu. See Section 9 **MMI Operation** for details.

If sensor is NEW, pull out electronics module slightly and measure voltage between probe points Cal 5 and Cal 6 on the display card. Use 200mV scale on the multi-meter and adjust the null Potentiometer to get 000.0 mV. This provides an initial adjustment of the Wheatstone Bridge, removing possible signal distortions.

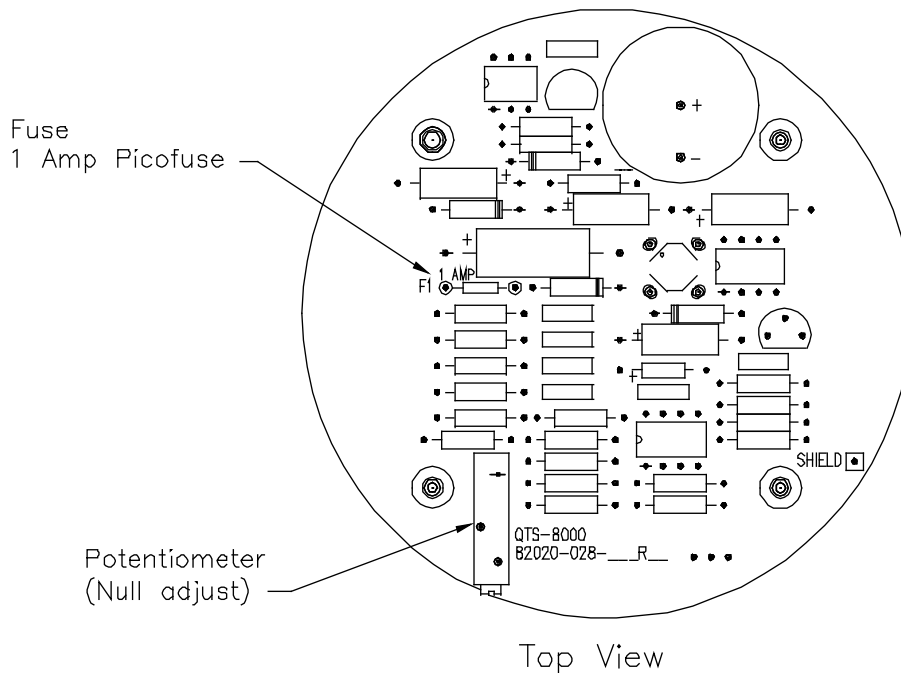

Figure 4 Catalytic Sensor Card Configuration

6.2 Electrochemical Sensor

Electrochemical sensor must be selected both by DIP Switches on the electrochemical sensor card and in the CONFIG menu.

- **Sensor selection in the CONFIG Menu:**

In the OFFLINE-->CONFIG--> SENSOR-> TOXIC menu, the sensor and the gas to be detected can be selected and the span can be set. See “9. MMI operation” for details.

- **DIP switch settings on the electrochemical sensor card for different sensors:**

Warning: Always turn the power off before any DIP Switch change.

O ₂	ON	ON	OFF	ON	ON	OFF	OFF	OFF	OFF	ON	OFF	ON	OFF	OFF
CO	ON	OFF	OFF	ON	OFF	OFF	ON	OFF	OFF	ON	OFF	OFF	ON	OFF
H ₂ S	ON	OFF	OFF	ON	OFF	OFF	ON	ON	OFF	ON	OFF	OFF	ON	OFF
SO ₂	ON	OFF	OFF	ON	OFF	OFF	ON	OFF	OFF	ON	OFF	OFF	ON	OFF
NO	OFF	OFF	ON	OFF	OFF	ON	OFF	OFF	OFF	ON	OFF	OFF	ON	ON
NO ₂	ON	OFF	OFF	ON	OFF	OFF	OFF	OFF	ON	ON	OFF	OFF	ON	OFF
H ₂	ON	OFF	OFF	ON	OFF	ON	OFF	OFF	OFF	ON	OFF	OFF	ON	OFF
HCN	ON	OFF	OFF	ON	OFF	OFF	OFF	ON	OFF	ON	OFF	OFF	ON	OFF
HCL	OFF	OFF	ON	OFF	OFF	OFF	ON	OFF	OFF	ON	OFF	OFF	ON	ON
NH ₃	ON	OFF	OFF	ON	OFF	OFF	ON	OFF	OFF	ON	OFF	OFF	ON	OFF
O ₃	ON	ON	OFF	ON	OFF	ON	OFF	OFF	OFF	ON	OFF	ON	OFF	OFF
C ₂ H ₄ O	OFF	OFF	ON	OFF	OFF	OFF	ON	OFF	OFF	ON	OFF	OFF	ON	ON
Cl ₂	ON	OFF	OFF	ON	OFF	OFF	ON	OFF	OFF	ON	OFF	OFF	ON	OFF
ClO ₂	ON	OFF	OFF	ON	OFF	OFF	ON	OFF	OFF	ON	OFF	OFF	ON	OFF

Table 3 Electrochemical Hardware Configuration

NOTE: For NO₂, SW2-5 is ON, R9 will be soldered on the display board

R9: SKU# 4110-1003 “RES 100K 1/4W 1% METAL FILM”

Note:

- 1) In the table, DSW n-m means DipSwitch number n , switch position m, for example, 1- 4 refers to DSW1, switch position 4.
- 2) Turn power supply off before any DIP switch changes.

3) Function of individual DIP switch:

- DSW2: Gain control
- DSW1-1 and DSW1-2: Short the reference and sensing electrodes when power is down
- DSW1-3: Negative biased for sensor
- DSW1-4: Non-biased
- DSW3-1: -0.3V biased
- DSW3-2: -0.4V biased
- DSW4-1: For positive output sensor
- DSW4-2: For negative output sensor
- DSW4-3: Backup battery for biased sensor when power is down.

See **Table 3** for the positions of the DIP switches.

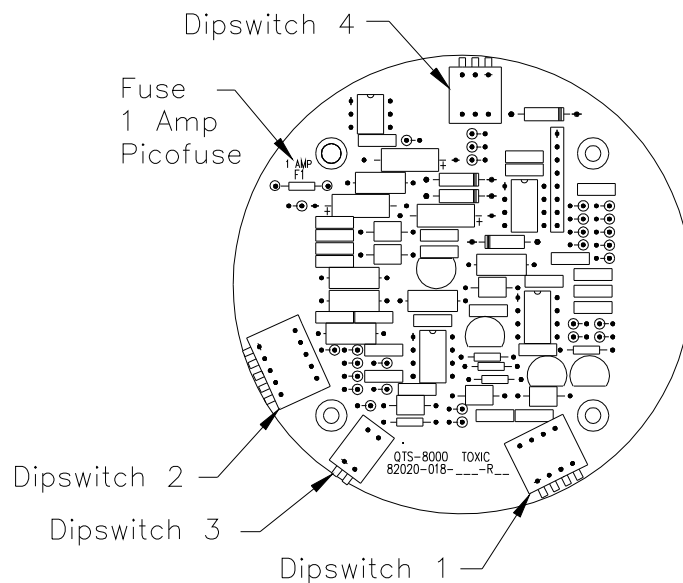

Figure 5 Electrochemical Configuration

6.3 Span Setting

For toxic gas, the span (or range) for individual gas and sensor can be set at any value between values shown in Table 1 at the beginning of this manual

The span is set in the OFFLINE--> CONFIG. --> SPAN menu. See **8 MMI operation** for details.

7. Other Configuration Items

7.1 Pluggable Terminal Blocks

All terminal blocks are pluggable to increase ease of wiring.

7.2 Fuses

A single socketed fuse (pico fuse) is located on the electrochemical and combustible sensor input cards and IR interface Board, rating = 1.0A.

Another fuse is located on the Extended Feature Card. Rating = 1.0A.

7.3 Signal selection

Signal by 4 - 20 mA or 0 - 10V can be selected in OFFLINE-->CONFIG. --> SIGNAL menu. See Section **8 MMI Operation** for details.

7.4 Setpoint

The actuation setpoint, de-actuation setpoint, actuation delay, de-actuation delay, relay latched/not latched and high/low relay trigger are set in the OFFLINE--> SETTING Menu. See **8 MMI Operation** for details.

Note: Setpoint actuation /alarm indication is a standard feature. If there is no Extended Feature Card, then the Display LEDs still operate.

7.5 Backup battery for calendar and real-time clock

There is a jumper J3 on display card for backup battery of the calendar and real-time clock. The battery also supplies power to the first gain stage of the electrochemical circuits to maintain the sensor in a continuously ready mode. Because of this, the circuit draws significantly more current than is usually the case when supplying only the clock circuit.

THE BATTERY IS NOT RECHARGEABLE. The position 1-2 connects the backup battery and the position 2-3 disconnects backup battery. Always put the jumper to 1-2 when the transmitter is ready to operate, and then set the calendar and the clock. Put the jumper to 2-3 when the transmitter is out of operation for a long time to save the battery.

Warning: Always turn the power off before jumper changes.

7.6 Digital Communications

Details concerning digital communications, installation and protocols is covered in QEL Manual **82050-005-000 - QTS-8000 RS-485 Communications Protocols**

7.6.1 Digital Addressing

The transmitter address used in data communication network can be selected in OFFLINE-->CONFIG. --> ADDRESS menu the. See Section **8 MMI Operation** for details. Address range is from 0 to 255.

7.6.2 Protocol selection

The protocol used by data communication can be selected in OFFLINE-->CONFIG. --> PROTOCOL menu the. See Section **8 MMI Operation** for details.

7.6.3 RS-485 Configuration

7.6.3.1 RS-485 Line Termination

RS-485 communications cables must be terminated at both ends by a load-matching resistor of 120 ohms. The QTS-8000 supplies the resistor on the Extended Feature Card. It is selected ON with Jumper J1 in the 1-2 position. (Ship standard = 2-3 position).

7.6.3.2 RS-485 Shield Termination to Case

Dipswitch 1 on the Extended Feature Card allows the option of connecting the RS-485 cable shield to QTS-8000 case ground. Switch both switches to ON to make the connection.

7.6.3.3 RS-485 Driver Replacement

RS-485 lines in heavy industrial environments are sometimes subjected to magnetic disturbances causing sufficient inducted power surges to damage the driver integrated circuit (IC). This IC is socketed on the circuit card for ease of replacement in the field.

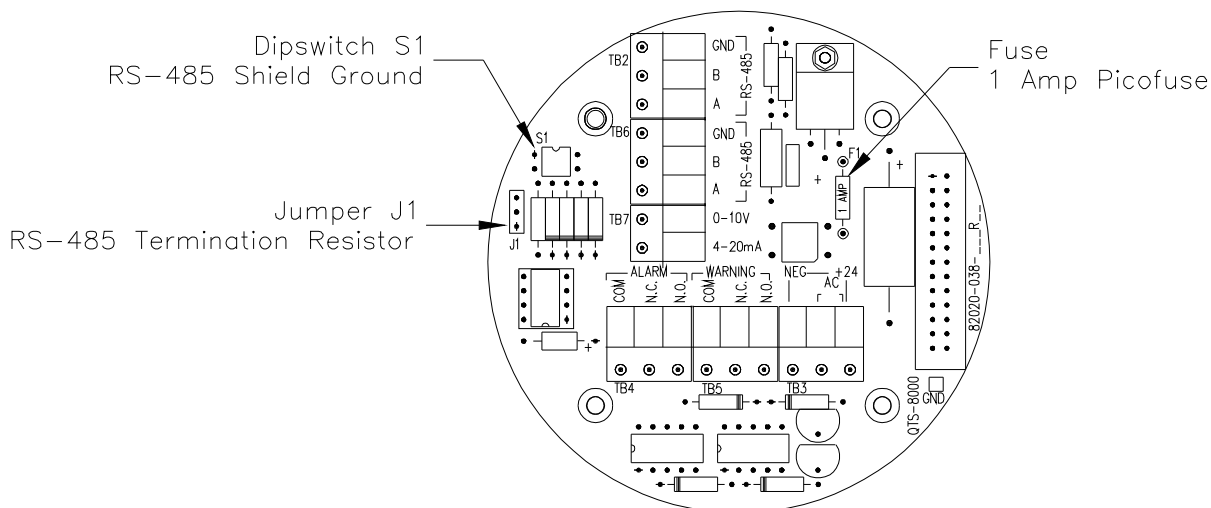

Figure 6 Extended Feature Card Configuration

8. Gas Calibration

See Section 8 **MMI Operation** for menu operation in detail.

8.1 Calibration jacks and equipment

Calibration jacks (CAL1 to CAL6) have been provided on the display card. These jacks accept standard multi-meter 0.080" probes (See Figure 1). The gas concentration under measurement or calibration is also shown on the LCD display.

Equipment for calibration:

- Calibration gas.
- A calibrated Digital Multi-meter (DMM)
- A small screwdriver and a magnetic tool.

8.2 Calibration Self Checks

The calibration process is software mediated. The software performs a number of operational checks at each step before allowing calibration to proceed. The software checks for signal stability and response strength. If one of these conditions is not correct then calibration is halted and a failure indicated. Possible reasons for calibration failure are as follows:

Catalytic/IR Sensors

- Sensor internal open circuit fault. (Display = Failure/Dead)
- Sensor Null out of adjustment too far (can be caused by gas present). (Display = Failure/Zero)
- Sensor response too weak. (Display = Failure/OUTrang)
- Signal not stable. (Display = Failure/OUTrang)

Electrochemical sensors

- Sensor zero out of range (Display = Failure/Zero)
- Sensor response too weak (Display = Failure/OUTrang)
- Signal not stable. (Display = Failure/OUTrang)

8.3 Calibration for combustible gas transmitter(Catalytic)

8.3.1 Zero calibration

- Apply zero gas. Go to OFFLINE -> Cal. to select the gas used for calibration if the gas is methane, propane or hydrogen, or OFFLINE -> Cal. -> Others to set the **J** = $K_{\text{methane}}/K_{\text{gas}}$ for the gas used for calibration.
- Select Zero to start zero calibration by software automatically. The display will show “Zero Cal. O.K. ” if the zero calibration is completed successfully, otherwise the calibration is failed.
- If zero calibration is failed, adjust the Null potentiometer on combustible sensor card and check the voltage between CAL5 and CAL6 to zero roughly, and then start zero calibration by software again.

8.3.2 Span calibration

- You may go back to *on-line* mode. There will be a wait of 10 seconds. Apply the gas used for calibration. Wait until the concentration on the LCD display is stable.
- Go to OFFLINE -> Cal. -> No Change, because the gas used for calibration has been selected during zero.
- Select Span to start span calibration by software. Modify the value on the LCD display with **Up** or **Down** keys to the same concentration with the applied gas when the LCD display shows the concentration. After that, accept the span by **Accept** key to finish the calibration.

8.4 Calibration for toxic gas transmitter

8.4.1 Zero calibration

- Apply zero gas. Go to OFFLINE -> Cal. -> Zero to start zero calibration by software automatically. The display will show “Zero Cal. O.K” if the zero calibration is completed successfully, otherwise the calibration is failed.
- Go back to *On-line* Mode.

8.4.2 Span calibration

- In *on-line* mode, apply calibration gas with a certain concentration.
- Wait until the concentration on the LCD display is stable.
- Go to OFFLINE -> Cal.-> Span to start span calibration by software. Modify the value on the LCD display with **Up** or **Down** keys to the same concentration with the applied gas when the LCD display shows the concentration. After that, accept the span by **Accept** key to finish the calibration.

8.5 Calibration for combustible gas transmitter (IR)

8.5.1 Zero calibration

- Apply zero gas. Go to OFFLINE -> Cal. -> Zero to start zero calibration by software automatically. The display will show “Zero...” and “ Done ” if the zero calibration is completed successfully, otherwise the calibration is failed.
- Go back to *On-line* Mode.

8.5.2 Span calibration

- Go to OFFLINE -> Cal.-> Span to start span calibration by software. Click “Accept” key and the display will show “CAL. GAS XX.X%LEL”, you can modify the value on the LCD display with **Up** or **Down** keys to the same concentration with the applied gas. After that, accept the span by **Accept** key to finish the calibration, The display will show “Span Calibrating” and “ Done ” if the Span calibration is completed successfully, otherwise the calibration is failed.

8.6 Zero and Span Checking

- In *On-line* mode apply zero gas. Check if the concentration on LCD display is zero and the current signal is 4.0 mA between CAL4 and CAL3 (with load and without interrupting signal) or between CAL4 and CAL2 (without load) or voltage signal between CAL1 and CAL2 is almost 0V, depending on output signal configuration.
- Apply the Span gas for checking. Check if the concentration on LCD display and the output signal are both correct.

9. MMI Operation

9.1 MMI Operation

The MMI is menu-driven. The LCD display has 8 x 2 characters. Only two rows in each menu can be displayed on the LCD at a time. In 9.2 Menu Demo, the row with shadow is the menu-head, and is always displayed on the first row of LCD. Others can be scrolled by **Up** or **Down** key to be displayed on the second row.

A key is touched by putting a magnetic tool very close to the front plate marked with \uparrow, \downarrow , ACCEPT or EXIT.

9.1.1 The keypads function:

- Up** (\uparrow) ---- to scroll the menu *up* or to increase the value which is under setting.
- Down** (\downarrow) ---- to scroll the menu *down* or to decrease the value which is under setting.
- Accept** ---- to *accept* the item or value which is under setting. The value will be written to EEPROM.
- Exit** ---- to *exit* the current item or to *quit* the value which is under setting. The value will not be written to EEPROM.

9.1.2 The step mode and fast mode:

The keypad is normally in step mode that means when a key is touched the item or value will change one step. If a key is kept in touch for more than 5 seconds, it will go to fast mode which means as long as the key is kept in touch the value will be changed continually.

9.1.3 Password:

There are two passwords. One is for *general* use, one is for *configuration*. When the transmitter is in *on-line* mode, if any key is touched, the LCD will show the password box and wait for the *general* password entry. If the password is correct, the transmitter will enter the *off-line* mode.

If the password is wrong or no password is entered, it will go back to *on-line* mode. The password for configuration is used to enter the configuration menu in which the configuration of the transmitter can be set or changed. Both passwords can be changed in the OFFLINE-->PASSWORD menu which can be entered by passing the configuration password check..

The default password for both is 0000.

CAUTION **Always record your password!**

9.2 Menu Demo

- **Main Menu:** To choose submenu.

OFFLINE
Setpoint Cal.
Config. Password Clock
Output

- **Setpoint Menu:** To set stepoints for warning and alarm relays

SETPOINT
Warning Alarm

Warning Menu:

WARNING
Actuate Deactuate Act-time Deactime Latch/no Hi/Lo

Alarm Menu:

ALARM
Actuate Deactuate Act-time Deactime Latch/no Hi/Lo

Note:

Latch/no ---- relay is latched after actuated/relay is not latched after actuated.

Hi/Lo ---- relay is actuated when gas concentration goes from low to high/from high to low.

- **Calibration Menu:** To calibrate the transmitter.

CAL.
Zero
Span
Last cal

If the transmitter is configured for combustible gas:

CAL. GAS
Methane
Propane
Hydrogen
Others
No change

If **Methane**, **Propane** or **Hydrogen** is chosen, transmitter will take the default **J** value; If **Others** is chosen, use **J set** to set **J**. If **No Change** is chosen, then the microprocessor will use the **J** value chosen in the last calibration

J set
*.***

$$J = K_{CH4}/K_{gas}$$

- **Configuration Menu:** To configure the transmitter.

CONFIG.
Sensor
Span
Address
Signal.
Protocol

Sensor Menu: To select sensor.

SENSOR
Combust
Toxic

If toxic is selected,
Toxic Menu:

TOXIC	
O	6C
CO	7E
H ₂ S	7HH
SO ₂	7SH
NO	7NT
NO ₂	7NDH
H ₂	7HYT
HCN	7HCN
HCL	7HL
NH ₃	7AM
NH ₃	A7AM
Ozone	7OZ
C ₂ H ₂ O	7ET
C ₁₂	7CLH
ClO ₂	7CLH

If combustible is selected,
Combustible Menu:

COMBUST
Methane
Propane
Hydrogen
Others

If **Methane**, **Propane** or **Hydrogen** is chosen, the transmitter will take the default **J** value; If others is chosen, use **J set** to set **J**.

J set
*.***

SPAN

**** = 0.100 - 2000 ppm

Communication Address: To set transmitter address in the communication network

Address

*** = 0 to 255

Output signal Menu: To select 4 - 20 mA or 0 - 10 V as signal

SIGNAL
4 - 20mA
0 - 10V

Protocol Menu: To choose protocol and baud rate

PROTOCOL
Baud rate
OPTO 22
HART
MODBUS

Baud rate Menu:

BAUD RATE
9600 bps
4800 bps
2400 bps
1200 bps

- **Password Menu:** To change passwords.

PASSWORD
General
Config.

- **Clock Menu:** To set year, month, date and clock for the real time clock in the transmitter

CLOCK
Year
MM/DD
Hour/min

If year is chosen:

Year
**

** = 00 - 99

If Month/day is chosen:

MM/DD
**/##

** = 1 - 12, ## = 1 - 31

If Hour/minute is chosen:

Hour/min
**/##

** = 0 - 23, ## = 0 - 59

- **Signal Menu:** To produce selected signal for outside testing

OUTPUT
4 mA
20 mA

10. Operating Inspection and Maintenance

10.1 Operation Inspection

The *fault* LED indicator on the plate of transmitter is used to indicate operating status of the transmitter. The *fault* indicator will be turn ON when the self-check facility diagnoses any fault in the transmitter, and the LCD display will show fault message to indicate fault types.

10.2 Maintenance

Calibration should be done with gas every 90 days maximum. In critical areas it may be prudent to test more often.