

Wireless Interface RAD-ISM-900-SET-BD...

Two-way (Point-to-Point) Monitoring and Control with Expandable I/O Options

User Manual



L001662

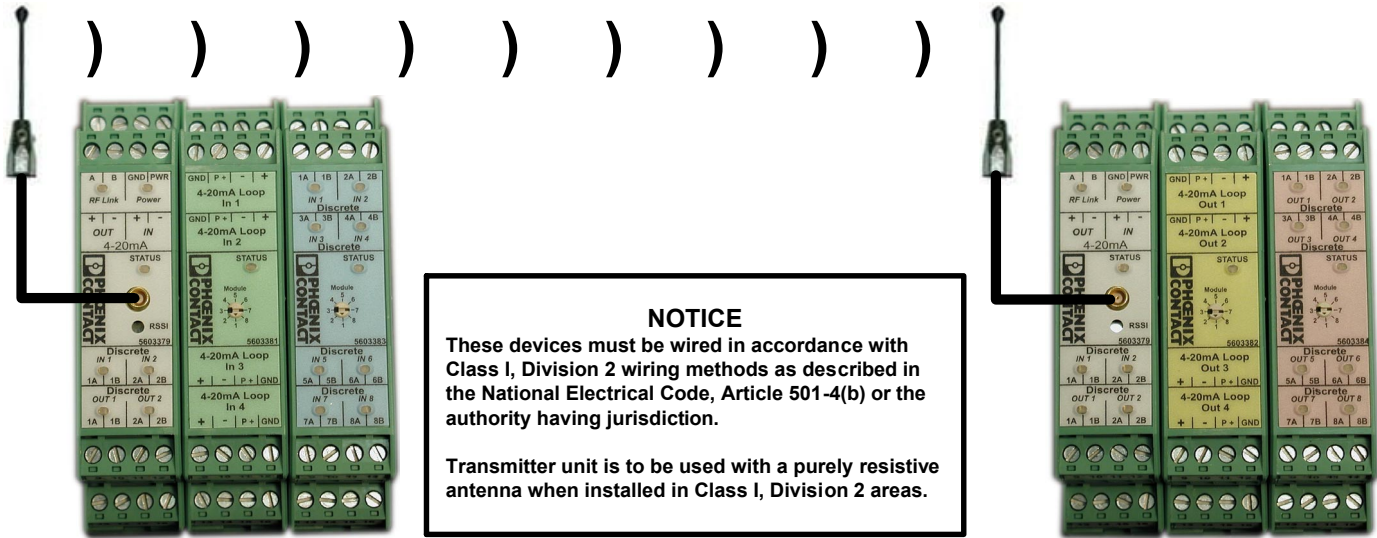

- Modular DIN-rail mount transceiver and I/O
- No programming required
- Maximum thirty-three (33) analog or sixty-six (66) discrete signals in one direction
- Class I, Div. 2 approved
- Dry contact RF LINK diagnostic output
- Up to eight (8) expandable I/O modules (passive inputs and outputs) per transceiver on common power and communications bus with multiple combinations

The Phoenix Contact RAD-ISM-900-BD is an integrated radio & I/O module designed for bidirectional interfacing of a 4-20 mA current loop and two digital signals in harsh industrial environments. This unique design also allows the user the flexibility to add on multiple channels of I/O to the paired transceivers in combinations. The Frequency Hopping Spread Spectrum (FHSS) utilizes 902-928MHz ISM band to guarantee a license free, interference free link between remote devices and the control room. The design is ideal for moving numerous signals within high interference environments without costly cable and conduit runs.

FCC Rules and Compliance

This device complies with Part 15 of the FCC Rules. Operation is subject to the following two conditions: (1) This device may not cause harmful interference, and (2) this device must accept any interference received, including interference that may cause undesired operation. Changes or modifications not expressly approved by Phoenix Contact will void the user's authority to operate the equipment.

This product is intended for fixed installation applications. In order to comply with FCC/ISC adopted RF exposure requirements, installation of this transmitter system's antennas must be performed in a manner that will provide at least a 6 foot (2m) clearance from the front radiating aperture to any user or member of the public.

FCC Part 15.247
 ISC RSS 210
 CSA/C & US/UL Class I, Div 2 (Groups A,B,C,D - pending)



RAD-ISM-900-BD Transceiver

Analog and Discrete *INPUTS*

Input Example 1

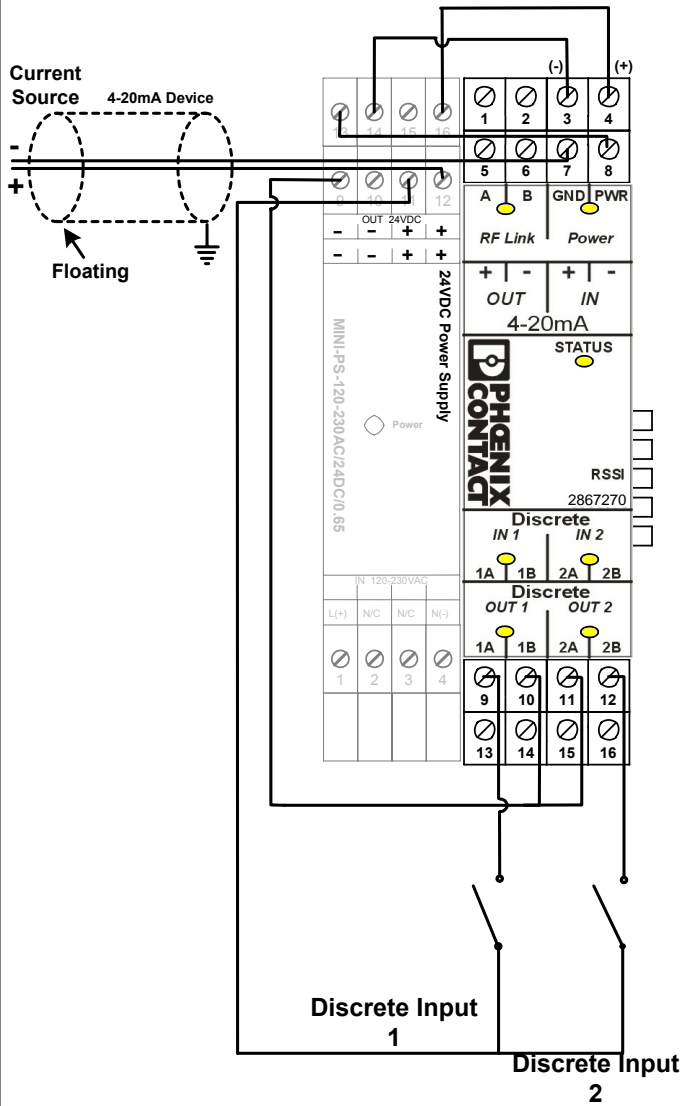

2-Wire Device 4-20mA Current Loop

Input Example 2

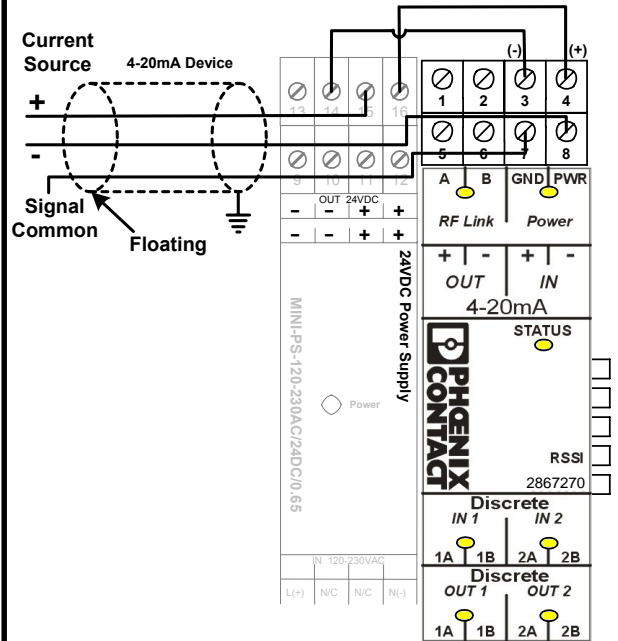

3-Wire Device 4-20mA Current Loop

Input Example 3

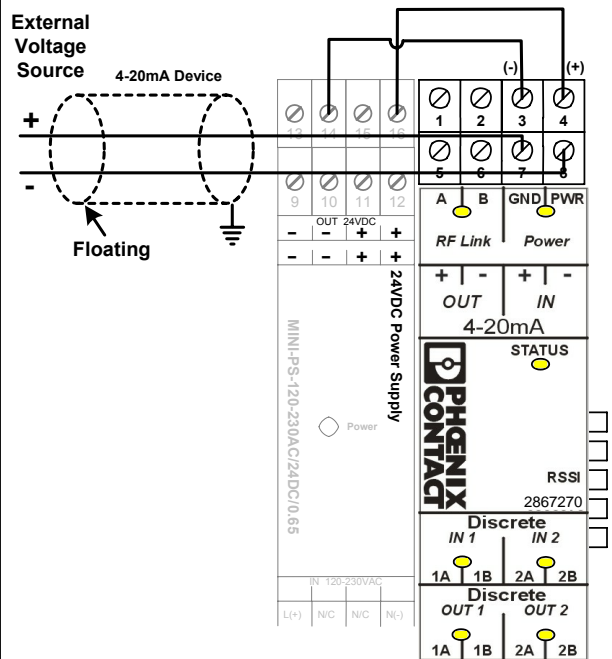

4-Wire Device 4-20mA Current Loop

RAD-ISM-900-BD Transceiver

Analog and Discrete *OUTPUTS*

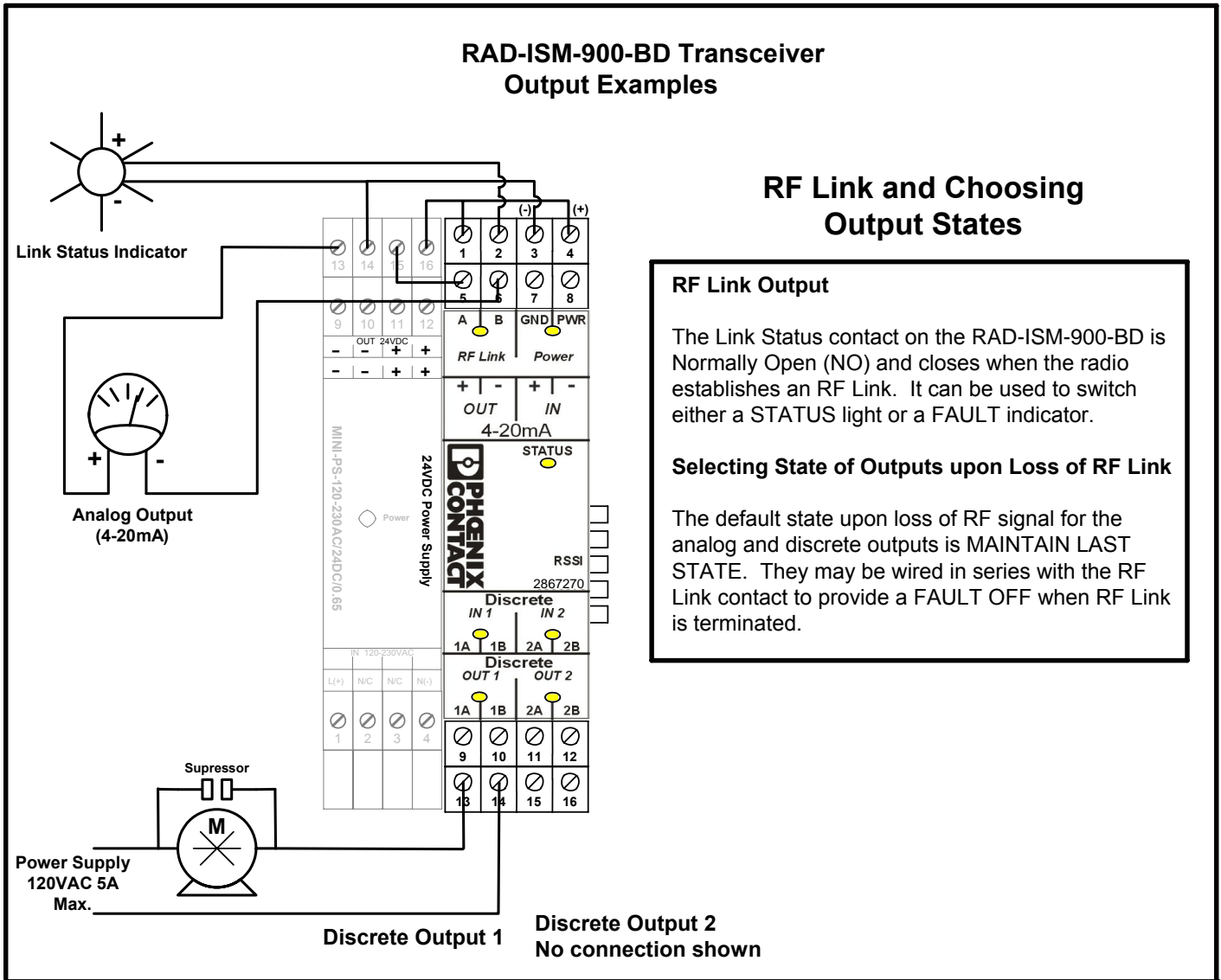

RAD-ISM-900-BD Transceiver Block Diagram

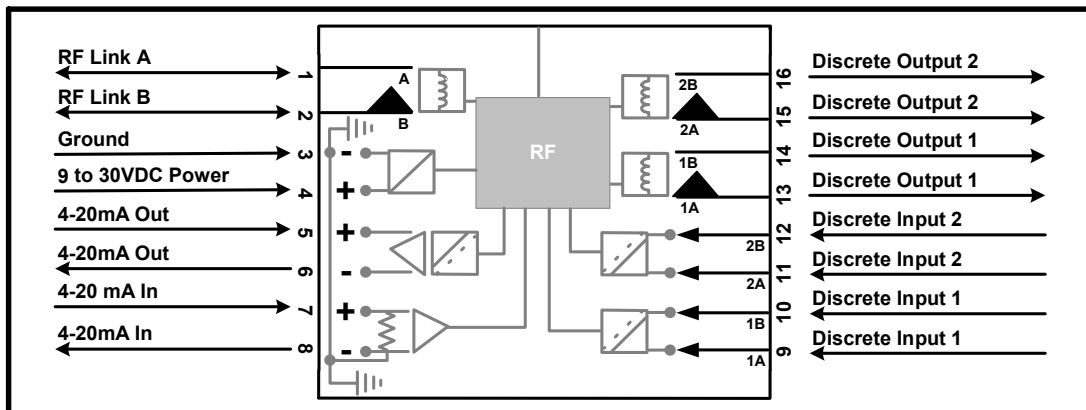

RAD-IN-4A-I Passive Inputs and Outputs

Analog Expansion Modules

RAD-IN-8D

Discrete Expansion Modules

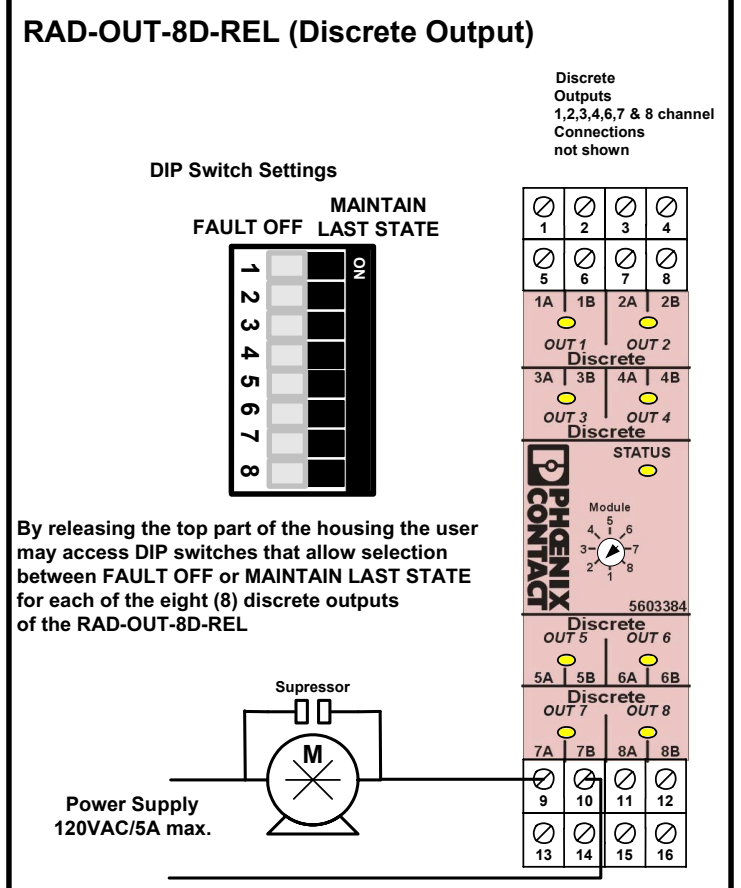
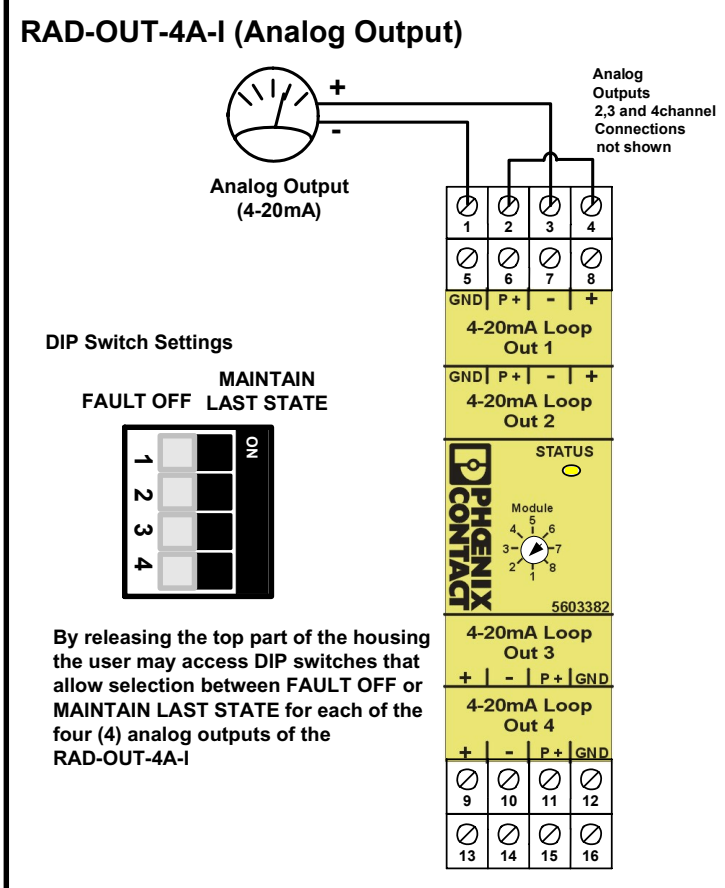
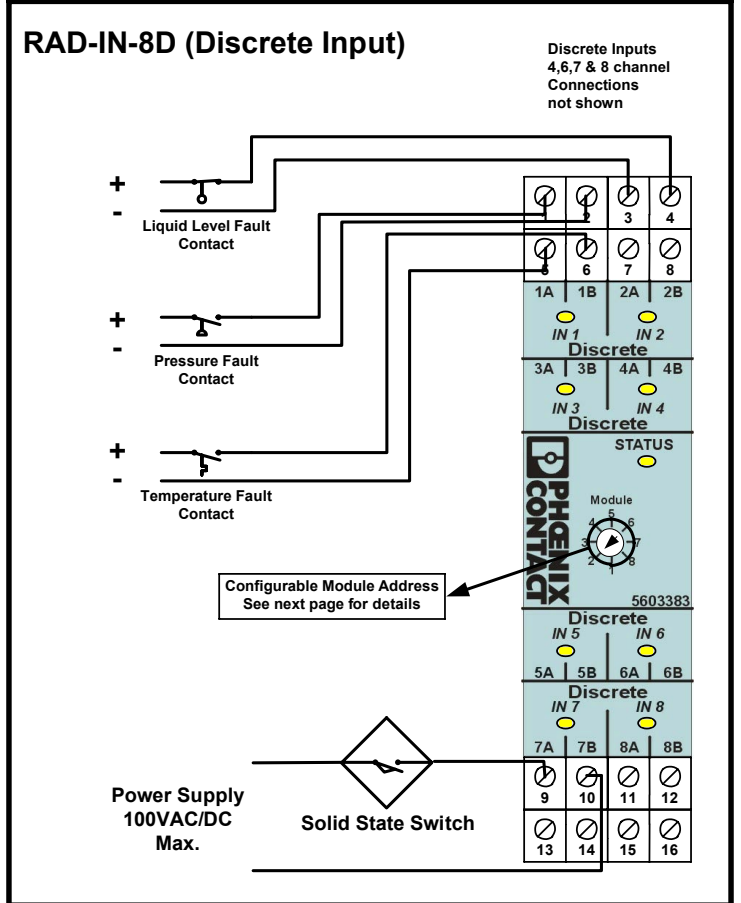
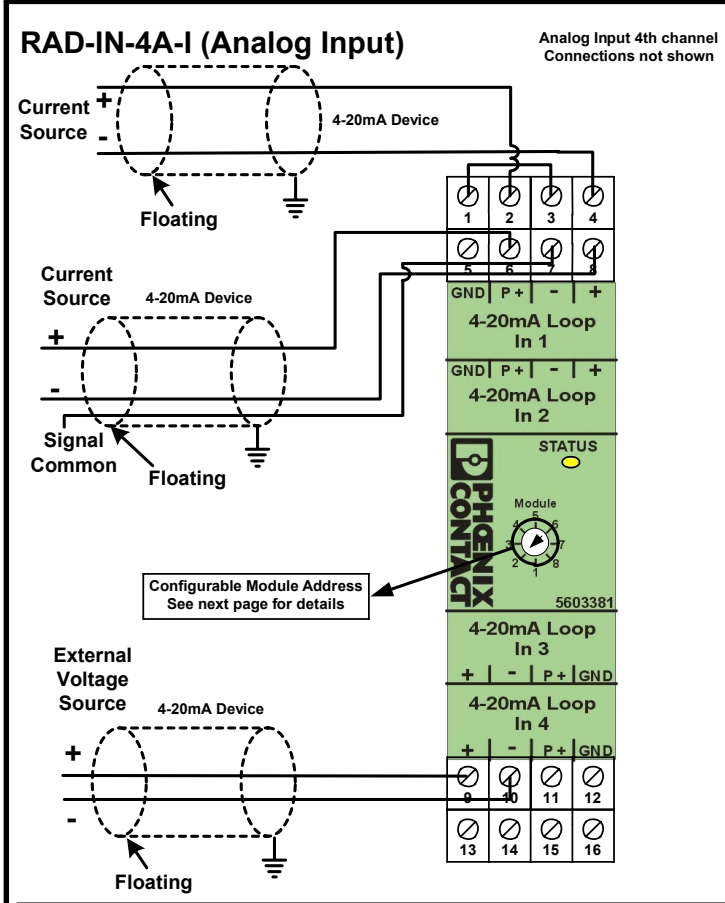

Configuring I/O Module Addresses

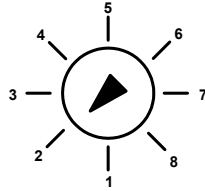
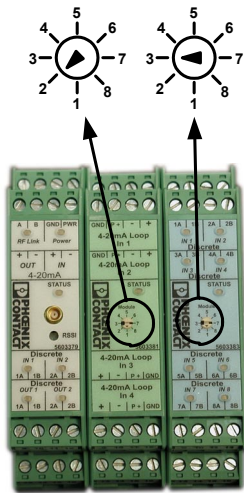

Module Address Selection Switch

Each pair of I/O modules, such as the RAD-IN-4A-I (2867115) and the RAD-OUT-4A-I (2867128), must share a unique module address. Once a module address has been assigned to a pair of I/O modules, that module address may not be used on any other pair of I/O modules on the same radio pair. Available addresses are numbers 1 through 8. If module addresses conflict, or are improperly set within a connected group, an indication will be given by the STATUS LED (see section below).

The RAD-ISM-900-BD transceivers are designed to operate as matched pairs and are factory programmed. Manual address configuration is not required for the transceiver units.

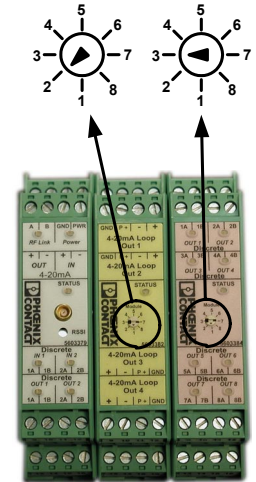

Power Budget Requirements (assuming internal bus power is used for analog I/O****)

The following table may be used as a reference when determining your power supply requirements. Total power requirements are shown per module, per side of the system. For example, the Transmitter side may have one (1) Transceiver, one (1) RAD-IN-4A-I (2867115) Expansion Module and one (1) RAD-IN-8D (2867144) Expansion Module. The total power requirement for this side of the system would be 213mA. [75 mA + 26 mA + 32 mA + (4*20 mA)]

The matching Receiver side would have one (1) Transceiver, one (1) RAD-OUT-4A-I (2867128) Expansion Module and one (1) RAD-OUT-8D-REL (2867157) Expansion Module. The total power requirement for this side of the system would be 287mA. [75 mA + 100 mA + 32 mA + (4*20 mA)]

MCR-RT-I/O-PLUS Rail Builder Power Budget Worksheet *			
	Quantity X	Power Requirement (in mA)	Total Power Consumption (in mA)
5603379 Transceiver **	1	75 ***	75
5603383 Expansion Module digital input	8 max.	26	208
5603384 Expansion Module digital output	8 max.	100	800
5603381 Expansion Module analog input	8 max.	32	256
5603382 Expansion Module analog output	8 max.	32	256
Analog I/O using Internal Power ****	8 max.	20	660
Total Power Supply Requirement (Sum of all devices used)			

* These currents are @ 24VDC.

** Allow for 200mA peak on the Transceiver.

*** 75mA (average), 200mA (peak)

**** If you are using internal power for the analog 4-20mA current loops, then you will need to add 20mA for each input and output being used in this fashion.

Status LED's

Power LED Power LED indicates presence of power to the device. It is ON when power is present and OFF when there is no power.

Status LED When flashing rapidly it indicates an "Internal Error" or a "Module Type Mismatch". A "Module Type Mismatch" occurs when the Module Address selection for two different modules (i.e. one (1) discrete module and one (1) analog module are set to the same address, or two (2) pairs of modules are sharing the same address). When Status LED is ON steady, Module Address settings are OK.

RF LED

- Flashes once every two seconds when there is no RF Link
- Flashes rapidly when signal strength is marginal (see RSSI Table)
- ON steady indicates an exceptionally strong RF Link.
- Most systems will flash occasionally indicating the presence of intermittent interference in the area

Discrete Input / Output

- OFF means that the discrete input or output is Open
- ON means that the discrete input or output is Closed

RSSI Troubleshooting

RSSI (Received Signal Strength Indicator) is measured using a DC Voltmeter between the test point and power supply ground. The test point is accessed by inserting a positive meter probe into the RSSI hole on the face of the RAD-ISM-900-SET-BD-BUS and the negative meter probe to the GROUND terminal.

The following RSSI table may be used to test the Receive Signal Strength of the RAD-ISM-900-BD. The ideal voltage that should be read from the RSSI test point is 2.5VDC. This represents a 90dB signal loss and typically indicates that the radio has 20dB fade margin left until loss of link. It is recommended that the radios be set up with no less than 20dB margin.

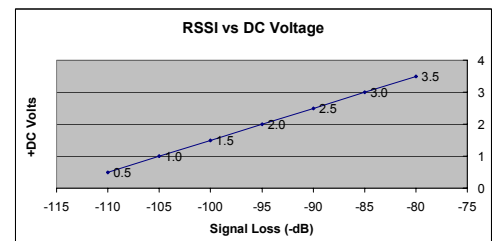

Typical Components for a RAD-ISM-900-BD Remote Site

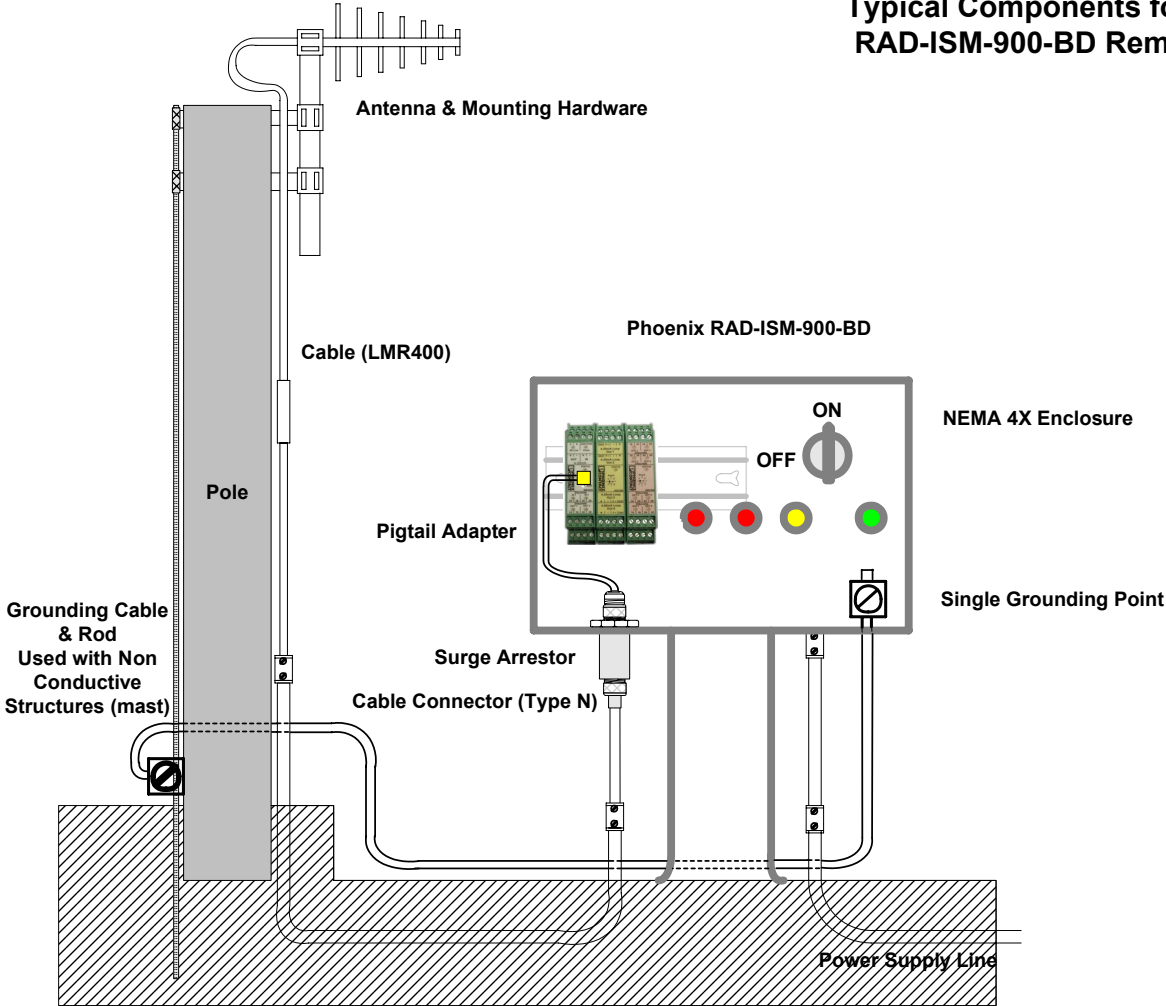

Wireless I/O Interface Ordering Information	
Part Description	Part Number
RAD-ISM-900-SET-BD-AN (two-way transceiver set with quarter-wave whip antennas)	2867270
RAD-ISM-900-SET-BD (two-way transceiver set without antennas)	2867089
RAD-IN-4A-I (four-channel analog input module)	2867115
RAD-OUT-4A-I (four-channel isolated analog output module)	2867128
RAD-IN-8D (eight-channel digital input module)	2867144
RAD-OUT-8D-REL (eight-channel digital output with relays)	2867157
RAD-ISM-900-BD (can be used as a spare or a repeater - requires ID number of transceivers)	2867092
RAD-ISM-900-1TX-2RX-BUS (configured as one-way system w/one transmitter & two receivers-expandable)	2867571
RAD-ISM-900-HOP-US (used to configure repeaters or replacement transceivers)	2867539
RAD-ISM-900-ANT-4 (4-way antenna splitter to cascade receivers in simplex mode)/MCX(M) to MCX(M) patch cable	2867050/5603376

Wireless I/O Accessories		
Item	Part Description	Part Number
Antennas	1/4 Wave Omni Antenna & 10' cable (0dB gain antenna L mount with BNC (M) connection)	2867173
	5dB Omni Base Station Antenna (5dB gain antenna L mount with 24" mast and propeller type base Type N(F) connector. (Requires cable adapter)	2867199
	6dB Yagi Antenna (6dB gain 3-element antenna with Type N(F) connector. Requires cable adapter)	2867209
	9dB Yagi Antenna (9dB gain 7-element antenna with Type N(F) connector. Requires cable adapter)	2867351
Cables	RG58 Cable (Cable loss = 16dB/100' (16dB/30.5m) BNC(M) & Type N(M) For distances less than 20'	2867393
	RG213 Cable (Cable loss = 7.6dB/100' (7.6dB/30.5m) Type N(M) both ends. For distances to 50'	2867225
	LMR400 Cable (Cable loss = 3.9dB/100' (3.9dB/30.5m) Type N(M) both ends. For distances up to 100'	2867238
Surge Arrester	Phoenix Contact COAXTRAB CN-UB-280DC-BB Type N(F) to Type N(F) Bulkhead Mount	5603859
Adapters	Type MCX(M) to N(M) adapter (4' RG316 cable)	2867254
	Type MCX(M) to BNC(F) / adapter for connection J0004	2867267/2867241

Antennas (a brief overview)

dBi

The FCC Part 15 regulations limit the antenna system gain for a 1 Watt unlicensed radio system to 6dBi.

This is based on an "isotropic" antenna model or "theoretical" antenna that radiates equally well in all directions. Such an antenna does not exist in the real world, but for purposes of determining the amount of antenna system gain permissible under Part 15 of this theoretical model is used.

The importance of understanding "theoretical" antennas versus "real" antennas has to do with the fact that the FCC views antenna gain in terms of dBi while the antenna manufacturers typically rate antenna gain in terms of dBd, which relates to a real world antenna known as a half-wave dipole. This difference in starting points influences "the math" a company like Phoenix uses when correctly determining the gain/loss of an antenna, cable and connector system it supplies.

How is "the math" influenced? Without going into a long technical discussion, simply stated, the difference between dBd and dBi is expressed by the value 2.15. An antenna with a gain of 3dBd is viewed by the FCC as having a gain of $3 + 2.15 = 5.15\text{dBi}$.

Since most end-users seldom use or understand dBd, dBi, or dBm (not discussed here), but instead use the general "catch phrase" dB when referring to the gain/loss of antenna system components, we recommend that they are aware of the fact that Phoenix Contact uses the following standard formula when determining Gain/Loss of an antenna system connected to a 1 Watt Phoenix FHSS radio.

Antenna gain (dB) - cable/connector losses (dB) + 2.15 = System Gain/Loss in dBi (not to exceed 6dBi)

Gain

In simple terms, gain can be thought of as the yardstick for determining how far a radio/cable/antenna system will transmit a signal by "focusing" the radiated energy produced by that radio. The simplest antenna - a 0dBi Omni - can be visualized as radiating signals in a sphere. To add "gain" to such an antenna, the radiation pattern of the energy can be shaped/focused, and in the case of an Omni directional antenna one thing that can be done is to flatten, or squish, the sphere. By turning the sphere into a donut, less energy is allowed to radiate vertically and more energy is diverted horizontally. An Omni antenna with its energy focused in this fashion will radiate energy further on a horizontal plane. Nothing is added to the system - only the radiation pattern is changed.

Loss

Loss is the yardstick, often given in "dB," for measuring the resistance of all the things that reduce the strength of a signal as it travels to the antenna. Cables, connectors, surge protectors, etc. all absorb energy from the signal as it passes through them. LMR400 cable, for example, has a loss of 3.9dB per 100 feet. When calculating antenna gain and cable loss, be sure to add 2.15 to the final value in order to convert the total dB gain/loss to dBi.

Gain/Loss Example

An antenna with 6dB gain will be mounted on a mast and require 100 feet of LMR400 cable. Using the formula given above, this would be calculated as $6\text{dB} - 3.9\text{dB} + 2.15 = 4.25\text{dBi}$. Since this is within the 6dBi limit, it would be acceptable under FCC Part 15 to implement this system.

Types of Antennas

Omni directional antennas radiate and receive signals in all directions. They usually resemble vertical rods but can come in other shapes as well. Some have horizontal rods at their base to form a ground plane for increased performance. Because Omni antennas focus their gain over a wide area, they are typically used at MASTER radios that need to send and receive information to and from many surrounding radios, and with radio systems separated by short distances or residing in obstructed locations where the signals are bouncing around structures and buildings.

Yagi antennas are uni-directional, meaning they have their energy focused tightly enough to only transmit and receive signals in the direction they are pointed. Yagi antennas are useful when you want to increase signal strength in one direction and send the signal farther than you could with an Omni antenna. They are typically used in outdoor installations to cover long distances from point to point.

Antenna Height

For maximum transmission effectiveness, several factors must be taken into account. Obviously, distances between antennas are important, as radio signals dissipate as they travel. The Fresnel Zone, or the space occupied by the propagating radio signal, changes shape as it travels across the earth and must be relatively clear of obstacles. For distances greater than 7 miles (11km), the curvature of the earth can adversely affect the radio link because it enters into the Fresnel zone. As a result, the overall formula for calculating approximate total antenna heights is:

Where:

H = antenna height in feet
D = distance between radios in miles

$$H=13.7 \sqrt{D + \frac{D^2}{8}}$$

To simplify this, refer to the table at the right to find the suitable minimum height of the antennas at each end of the link.

Mounting

No matter what type of radio you are using, to maximize the signal strength getting to the receiver, mounting the radios with in Line-of-Sight of each other is the best option. That much said, 902 to 928MHz signals (used by Phoenix Contact) have characteristics that lend themselves well to bouncing and reflecting off of objects. This enables them to perform well in industrial environments where Line-of-Sight cannot be achieved. To take full advantage of bouncing and reflecting signals in an obstructed environment, Omni directional antennas should be used and mounted in areas where they can radiate and capture signals coming from the maximum number of reflective surfaces. For example, in a refinery, mounting an Omni directional antenna outside the control room on a catwalk open to the superstructure of the facility, rather than burying it inside the control room, will greatly enhance the performance of the radio link.

When using Yagi antennas at remote sites to communicate back to a central MASTER with an Omni antenna, be sure to aim the Yagi's directly at the Omni and mount the elements of the Yagi antennas vertically - like the Omni. This will ensure maximum signal strength within the system.

If two Yagi antennas are used in a point to point application, their elements need to be aligned the same, either vertically or horizontally. Some system designers prefer to mount the Yagi elements horizontally as they feel this helps reduce interference from other radio systems in the area (which are typically vertically polarized).

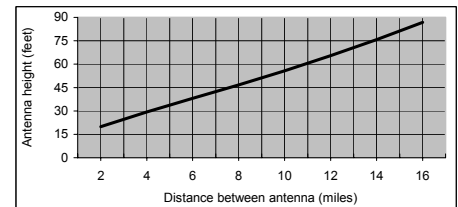

Specifications

2867270 RAD-ISM-900-BD	
General	
Range	600 to 1000 feet (180 to 305m) in-plant [obstructed]; 4-5 miles (6-8km) LOS with Omni antenna; 20+ miles (32+km) LOS with Yagi antenna
Inputs	One (1) 4-20mA analog input (16-bit, 125 ohms impedance) Two (2) discrete inputs (5-36VDC)
Outputs	One (1) 4-20mA analog output (16-bit, short-circuit protected) Two (2) discrete outputs (dry contact, NO, contact rating: 120VAC/5A)
I/O Expansion Capability	Four (4) analog and eight (8) discrete I/O modules
Repeatability	Current loop: 0.02%
Accuracy	Current loop: 0.2% of full-scale @ 77°F (25°C)
Wiring Connections	12-24 AWG screw-type terminals; removable terminal blocks
Mounting	DIN rail mount
Primary Power	
Input Voltage	9 to 30VDC
Reverse Polarity Protection	Yes
Surge Protection	Yes
Power Consumption	75mA (average) / 200mA (peak) @ 24VDC during transmission (plus I/O modules)
Transceiver	
Frequency	902 to 928MHz - ISM band
Transmit Power	1 Watt (30dBm)
RX Sensitivity	-105dBm
Unit ID	Factory configured (unique); 16-bit coding of each transceiver pair allows multiple units to be used in the same area
Antenna Connector	MCX female
Antenna Impedance	50 ohms
Diagnostics	
Indicators	External LED's (Power, RF Link, I/O status)/RF link relay 120 VAC/5 A
Environmental	
Humidity	20% - 90% (non-condensing)
Temperature	Operating: -40°F to 158°F (-40°C to 70°C)
Size	4.5" x 3.9" x 0.9" (114mm x 99mm x 23mm)
Weight	5.3 oz (150 g)
Enclosure	NEMA 1 (equivalent to IP20)
Agency Approvals	
FCC	Part 15.247
ISC	RSS 210
CSA/C & US	Class I Div 2 (Groups A, B, C, D - pending)
I/O Expansion Modules	
2867144 RAD-IN-8D Discrete Input Module – Low Volt	
Channels	Eight (8)
Input Voltage Range	5 to 36VAC/DC
Input Impedance	5K ohms
Optically Isolated	3kV (input/output and channel/channel)
Reverse Polarity Protected	Yes
Over-Voltage Rating	100VAC/DC max.
Power Consumption	26mA
2867157 RAD-OUT-8D-REL Discrete Output Module – 8 Ch, Relay	
Channels	Eight (8)
Output Terminals	Dry contact (NO)
Contact Ratings	120VAC/5A
Power Consumption	10mA @ 24VDC (outputs OFF) 100mA @ 24VDC (outputs ON)
2867115 RAD-IN-4A-I 4-20mA Analog Input Module – 4 Ch	
Channels	Four (4)
Resolution	16-bit
Input Impedance	125 ohms
Reverse Polarity Protected	Yes
Over-Voltage Rating	42VDC max.
Accuracy	0.2%
Power Consumption	32mA (inputs disconnected)
2867128 RAD-OUT-4A-I 4-20mA Analog Output Module – 4 Ch, ISOL	
Channels/Load per Channel	Four (4)/9 V voltage drop per channel
Resolution	16-bit
Short-Circuit Protection	Yes
Optically Isolated	3kV (input/output and channel/channel)
Accuracy	0.12%
Power Consumption	32mA (outputs disconnected)

