

Device Maintenance

Battery Replacement

Materials:
Small Phillips Head Screwdriver
Replacement Battery (LTC-7PN)

- Puncture the center of the back label with the screw driver and unscrew the enclosure.
- Remove the battery by pulling it perpendicular to the circuit board.
- Insert the new battery into the terminals and verify it is secure.
- Screw the enclosure back together securely.

Note: Be sure not to over tighten the screws or strip the threads.

Battery Warning

WARNING: FIRE, EXPLOSION, AND SEVERE BURN HAZARD. DO NOT SHORT CIRCUIT, CHARGE, FORCE OVER DISCHARGE, DISASSEMBLE, CRUSH, PENETRATE OR INCINERATE. BATTERY MAY LEAK OR EXPLODE IF HEATED ABOVE 80°C (176°F).

Recalibration

The RFRTDTemp101A standard calibration is two points, 50Ω and 150Ω.

Pricing:
Recalibration traceable to NIST \$60.00
Recalibration \$40.00

Additional:
As Found Data \$15.00 per parameter/channel
Verification Point \$15.00 per point
RTD Channel \$90.00
(RTD must be included, calibration point 25°C)
RTD Channel \$105.00
(RTD must be included, customer specifies 1 calibration point)

To send the devices back, visit www.madgetech.com, select Services then RMA Process.

Part Number	RFRTDTemp101A
External Temperature Sensor	External RTD 2,3 or 4 wire 100Ω pt RTD
External Temperature Range	-200 to +850°C Probe Dependant
External Temperature Resolution	0.1°C
External Temperature Accuracy	±0.1°C
Memory	5,461
Reading Rate	30 seconds up to 12 hours
LED	Red and Green
Required Interface Package	RFC101A
PC Baud Rate	57,600
RF Carrier Frequency	418 ± 0.075MHz
RF Baud Rate	4,800
RF Range	Typical Outdoors/Line of Sight: Up to 120' (36m) Typical Indoors/Urban: Up to 40' (12m)
Typical Battery Life	1 Year
Material	ABS Plastic
Operating Environment	-30 to +70°C, 0 to 95%RH (Non-Condensing)
Dimensions	1.7" x 2.7" x 0.8" plus 2.0" Antenna (43mm x 69mm x 21mm plus 51mm Antenna)
Approvals	US (FCC), CA (IC)

Specifications subject to change.

See MadgeTech's terms and conditions at www.madgetech.com

MadgeTech, Inc.
PO Box 50 • Warner, NH 03278
Phone 603.456.2011 • Fax 603.456.2012
www.madgetech.com • info@madgetech.com

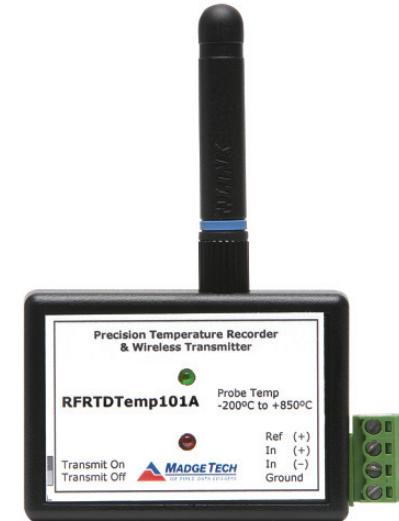

RFRTDTemp101A
Temperature and Humidity Recorder and Wireless Transmitter

Wiring the Data Logger

Wiring Options

For 4-wire RTD probes, connect the four lead wires to your RTD logger as shown in the figures below.

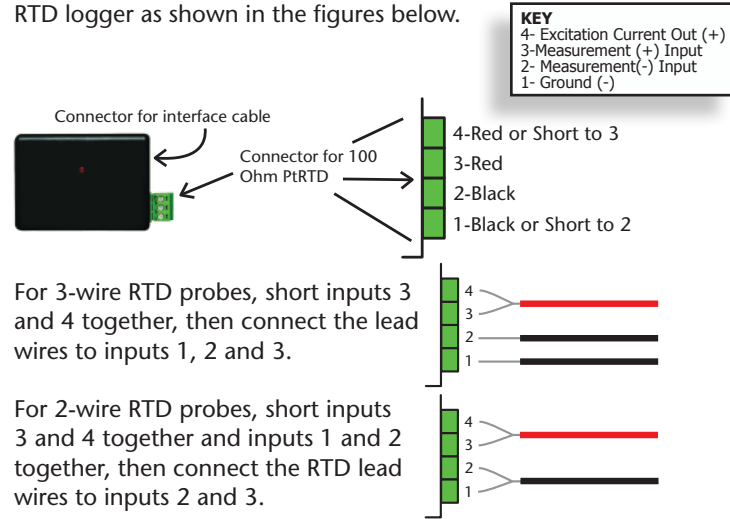

Product Notes

LEDs

Once started, the green LED will blink at the specified reading rate. The red LED will blink each time a reading is sent to the receiver. The LED on the RFC101A receiver will blink when a reading is received.

Alarm Settings

The wireless series does have alarm features. Refer to the "Operations Manual for RF Series Data Loggers" located on the software CD for a full list of instructions.

Installation Guide

Installing the Interface cable

- IFC200, IFC202 or IFC300
Refer to the "Quick Start Guide" included in the package.
- IFC110, IFC102 or IFC103
Plug the serial cable into the port and verify it is secure.

USB-1 or USB-101

Install the USB drivers from the CD provided in the kit, then plug the USB cable into the computer and the serial cable into the serial port.

Installing the software

Insert the Software CD in the CD-ROM Drive. If the autorun does not appear, locate the drive on the computer and double click on **Autorun.exe**. Follow the instructions provided in the Wizard.

Connecting the data logger

- Once the software is installed and running, plug the interface cable into the data logger.
- Click the **Communication Menu**, then **Auto Configure Port**.
- After a moment, a box similar to the following will appear;

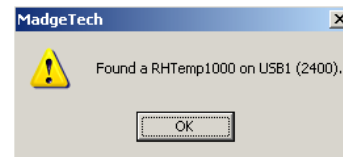

- Click **OK**. The **Device Status** box will appear. Click **OK**.
- At this point, communications have been configured for your logger. These settings can be found under the **Communication Menu**.

Note: For additional installation instructions refer to your "Data Logger & Software Operating Manual".

Device Operation

Starting the data logger

- Click **Device Menu** then **Start Device**.
 - Choose the desired start method.
 - Choose the start parameters by selecting a **Reading Rate** suitable for your application.
 - Enter in any other desired parameters and click **Start**.
 - A box will appear stating the data logger has been started. Click **OK**.
 - Disconnect the data logger from the interface cable and place it in the environment to measure.
 - Plug in the RFC101A receiver. Disconnecting the IFC110 is necessary.
 - Click the Communication Menu, Select Baud Rate. Select 4800 baud. This is the baud rate for the receiver.
 - Data will now transmit back to the PC from the data logger.
- Note:** The device will stop recording data when the end of memory is reached or the device is stopped. At this point the device cannot be restarted until it has been re-armed by the computer.



Downloading data from a data logger

- Connect the data logger to the interface cable.
- Click the **Device Menu** then **Read Device Data**. This will offload all recorded data onto the PC.

Technical Support

Visit www.madgetech.com, or call (603) 456-2011. Technical support is also available by e-mailing support@madgetech.com

Additional product information is available by e-mailing info@madgetech.com.