

When the meter is locked, parameters can be viewed, but not changed.

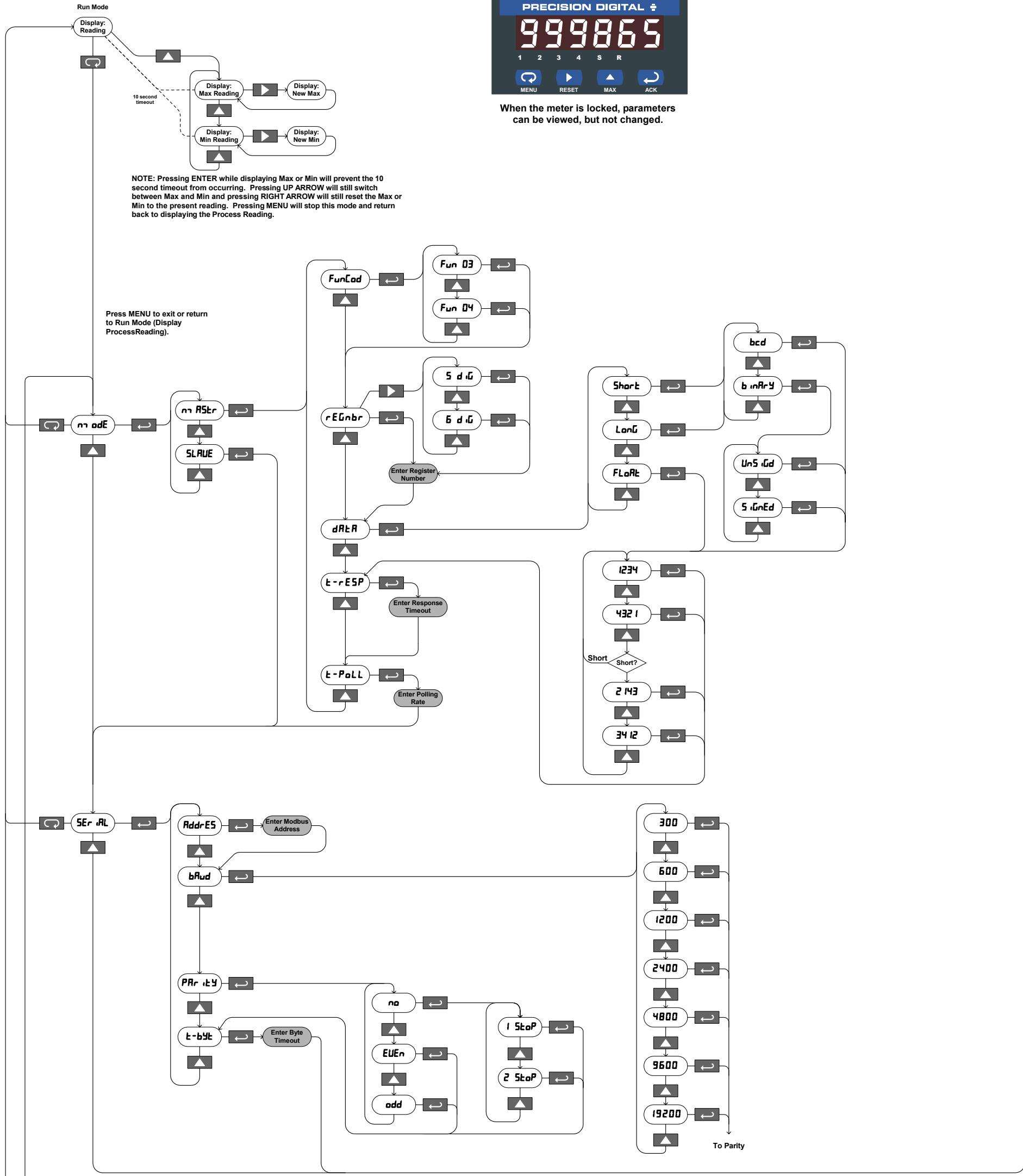

NOTE: Pressing ENTER while displaying Max or Min will prevent the 10 second timeout from occurring. Pressing UP ARROW will still switch between Max and Min and pressing RIGHT ARROW will still reset the Max or Min to the present reading. Pressing MENU will stop this mode and return back to displaying the Process Reading.

Press MENU to exit or return to Run Mode (Display ProcessReading).

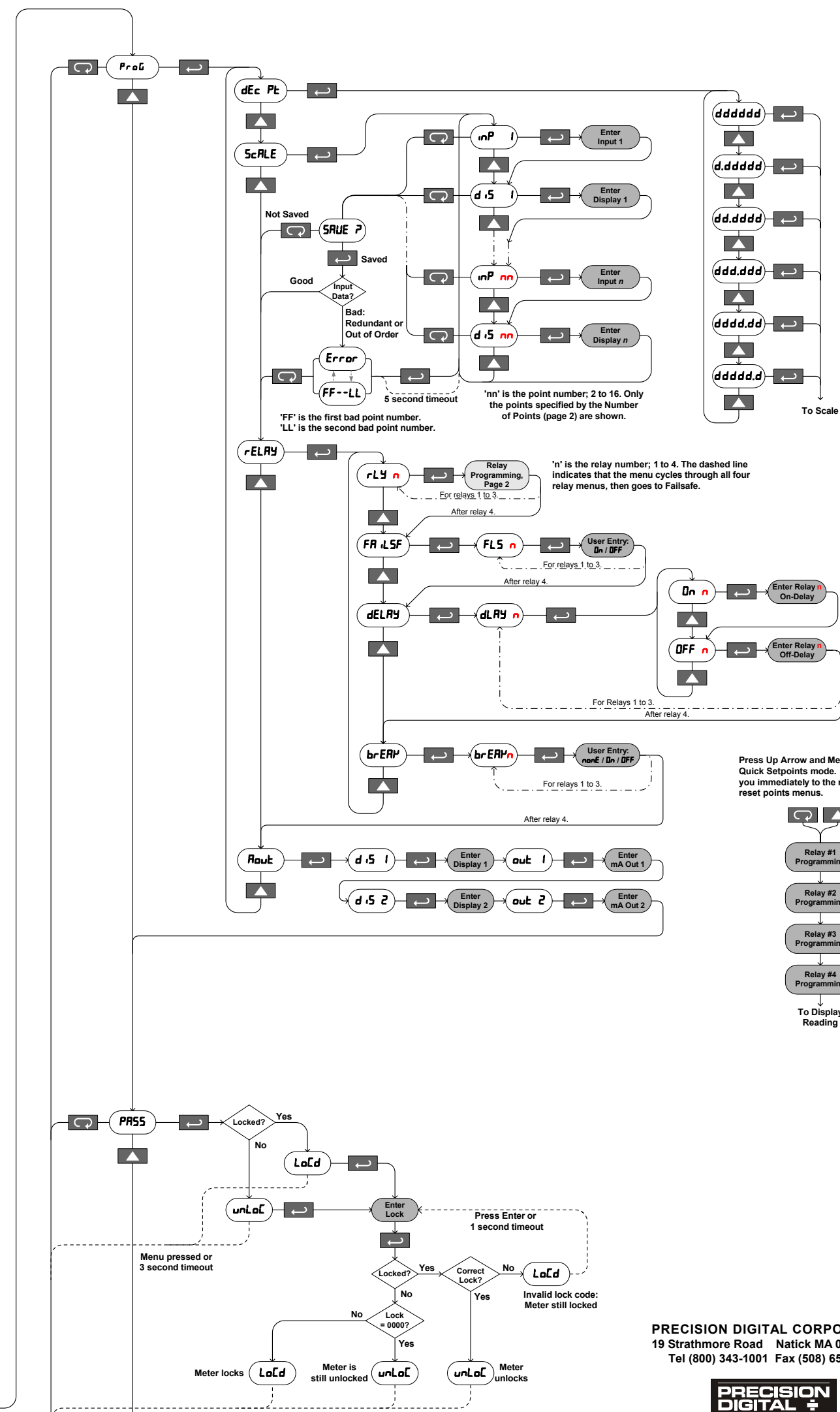

'FF' is the first bad point number. 'LL' is the second bad point number. 'nn' is the point number; 2 to 16. Only the points specified by the Number of Points (page 2) are shown.

'n' is the relay number; 1 to 4. The dashed line indicates that the menu cycles through all four relay menus, then goes to Failsafe.

Press Up Arrow and Menu to enter Quick Setpoints mode. This takes you immediately to the relay set and reset points menus.

PRECISION DIGITAL CORPORATION
19 Strathmore Road Natick MA 01760 USA
Tel (800) 343-1001 Fax (508) 655-8990

Hold for 3 seconds to enter Advanced Features.
If locked, data can be displayed but not changed.
MENU exits & returns to Run Mode.

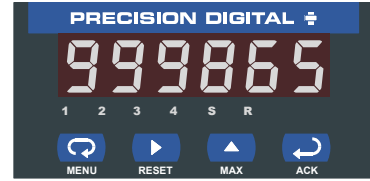

When the meter is locked, parameters can be viewed, but not changed.

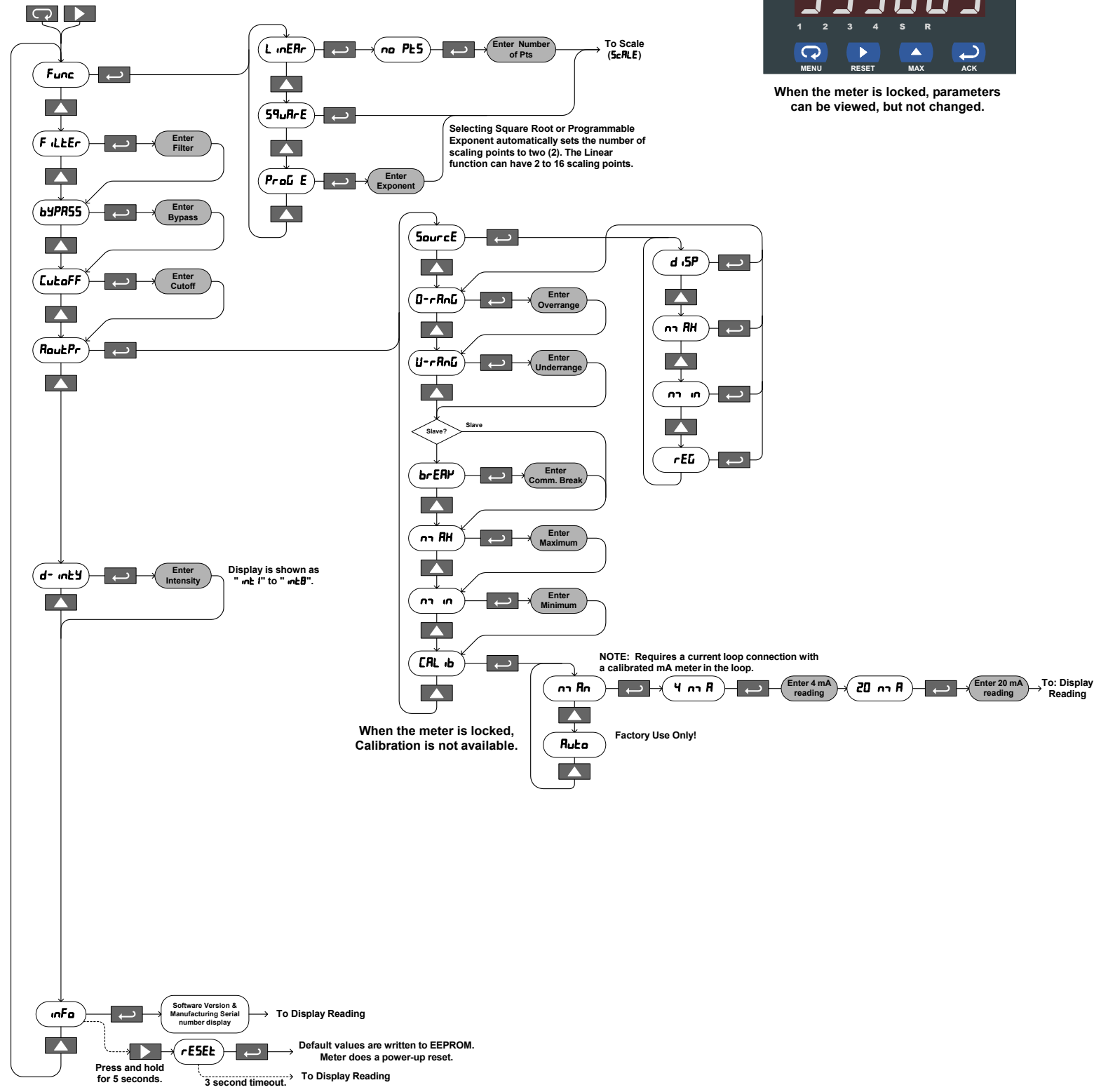

NOTE: Press and hold RIGHT ARROW for 5 seconds while inFo is displayed to enter Meter Reset Defaults mode (display shows rset). This is used to initialize the EEPROM to factory defaults. Press ENTER to accept. Press MENU or no keys for 3 seconds to exit.

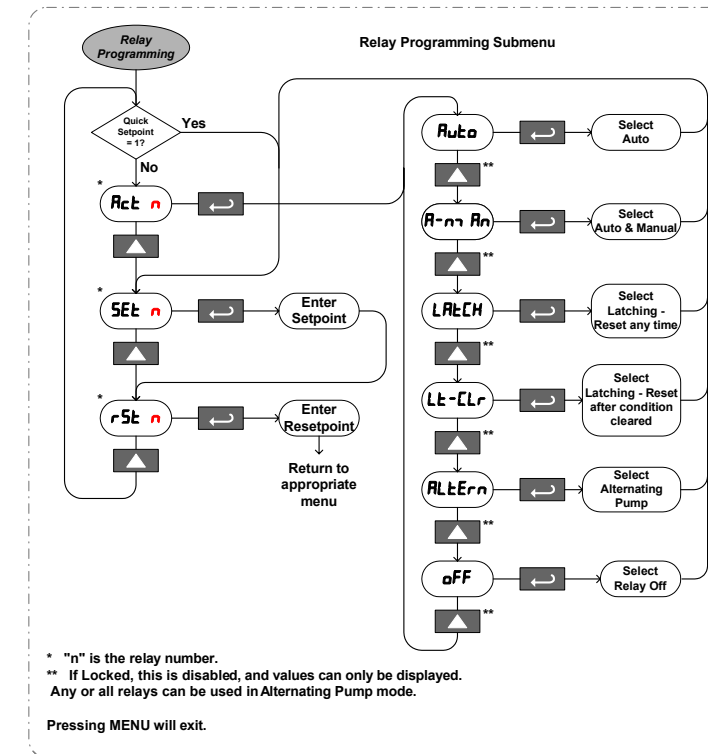

Snooper PD865 Quick Start Guide



www.predig.com

Slave Mode Register Tables

Register ¹		Name	Access	Limits or Range ²	Data Type ³	Function Code(s)	Comments																														
Number	Address (hex)																																				
40001 – 40002	0 – 1 (0000 – 0001)	Display value	Read Write	-199999 to +999999	Long	03, 04, 16	Represents the display value without the decimal point. Decimal point setting in 40013.																														
40003 – 40004	2 – 3 (0002 – 0003)	Maximum Display value	Read Write	-199999 to +999999	Long	03, 04, 16	Represents the Maximum display value, excluding the decimal point, since last power up or Max. Value reset. Decimal point setting in 40013. Writing any value will reset the max to the present display value.																														
40005 – 40006	4 – 5 (0004 – 0005)	Minimum Display value	Read Write	-199999 to +999999	Long	03, 04, 16	Represents the Minimum display value, excluding the decimal point, since last power up or Min. Value reset. Decimal point setting in 40013. Can be written to any value between -199999 to +999999. Writing any value will reset the max to the present display value.																														
40007	6 (0006)	Alarm and Relay Status	Read both, Write Relays	1 = In Alarm 1 = relay energized	Bits	03, 04, 06	Read alarm status and energized/non-energized status of relays. Alarms are read only; the upper byte is ignored for writes. Writing to a relay is only possible when the relay is in the Disabled mode. Alm = Alarm, Rly = Relay. <table border="1" style="margin-left: 20px;"> <tr> <td>15-12</td><td>11</td><td>10</td><td>9</td><td>8</td><td>7-4</td><td>3</td><td>2</td><td>1</td><td>0</td> </tr> <tr> <td>0000</td><td>Alm</td><td>Alm</td><td>Alm</td><td>Alm</td><td>0000</td><td>Rly</td><td>Rly</td><td>Rly</td><td>Rly</td> </tr> <tr> <td></td><td>4</td><td>3</td><td>2</td><td>1</td><td></td><td>4</td><td>3</td><td>2</td><td>1</td> </tr> </table>	15-12	11	10	9	8	7-4	3	2	1	0	0000	Alm	Alm	Alm	Alm	0000	Rly	Rly	Rly	Rly		4	3	2	1		4	3	2	1
15-12	11	10	9	8	7-4	3	2	1	0																												
0000	Alm	Alm	Alm	Alm	0000	Rly	Rly	Rly	Rly																												
	4	3	2	1		4	3	2	1																												
40008	7 (0007)	Alarm acknowledge	Write Only	0x0000 to 0x0F00	Bits	06	Clear Relay n alarm condition. Set bit equal to 1 to acknowledge. Only has effect on relays programmed to allow manual acknowledging. Alm = Alarm. <table border="1" style="margin-left: 20px;"> <tr> <td>15-12</td><td>11</td><td>10</td><td>9</td><td>8</td><td>7-4</td><td>3-0</td> </tr> <tr> <td>0000</td><td>Alm</td><td>Alm</td><td>Alm</td><td>Alm</td><td>0000</td><td>0000</td> </tr> <tr> <td></td><td>4</td><td>3</td><td>2</td><td>1</td><td></td><td></td> </tr> </table>	15-12	11	10	9	8	7-4	3-0	0000	Alm	Alm	Alm	Alm	0000	0000		4	3	2	1											
15-12	11	10	9	8	7-4	3-0																															
0000	Alm	Alm	Alm	Alm	0000	0000																															
	4	3	2	1																																	
40009	8 (0008)	Initialize meter	Write Only	0xFF00 to initialize.	Integer	06	Write 0xFF00 to reinitialize the meter. Writing any other data has no effect.																														
40010	9 (0009)	Lock	Read Write	0x0000 to 0x9999	Integer (Packed BCD)	03, 04, 06, 16	See note 4.																														
40011	10 (000A)	Mode selection	Read Write	Not applicable	Word; bit flags	03, 04, 06, 16	This Register is reserved for future use. Reading returns 0xffff and writing to it has no effect.																														
40012	11 (000B)	Data Type	Read Write	Not applicable	Word; bit flags	03, 04, 06, 16	This Register is reserved for future use. Reading returns 0xffff and writing to it has no effect.																														
40013	12 (000C)	Decimal Point	Read Write	0 to 5	Integer	03, 04, 06, 16	See Bit Assignment Table 1.																														
40014	13 (000D)	Transfer Function	Read Write	0 to 2	Integer	03, 04, 06, 16	See Bit Assignment Table 2. Selecting Square Root or Exponent forces Register 40015 (number of points) to be 2.																														
40015	14 (000E)	Number of Points	Read Write	2 to 16	Integer	03, 04, 06, 16	Number of scaling points. This cannot be changed if the Transfer Function is set to Square Root or Exponent.																														
40016 – 40017	15 – 16 (000F – 0010)	Exponent	Read Write	0.5 to 2.99999	Long	03, 04, 16	If Square Root is selected, this value is ignored.																														
40018	17 (0011)	Byte-to-byte timeout	Read Write	0 to 2.54	Integer	03, 04, 06, 16	This is the timeout between bytes of a Modbus frame. It is automatically changed to 1.5 * character time when the baud rate is changed.																														
40019	18 (0012)	Slave Response Timeout	Read Write	0 to 255	Integer	03, 04, 06, 16	Corresponds to 0.0 to 25.5 seconds. Not used in Slave mode.																														
40020	19 (0013)	Poll Time	Read Write	1 to 255	Integer	03, 04, 06, 16	Corresponds to 0.1 to 25.5 seconds. 0 is not allowed. Polling time has to be greater than or equal to slave response time. Master mode only.																														
40021	20 (0014)	LED brightness	Read Write	1 to 8	Integer	03, 04, 06, 16	8 is the brightest level.																														
40022	21 (0015)	Bypass	Read Write	2 to 999	Integer	03, 04, 06, 16	Corresponds to 0.2 to 99.9%. If the input steps greater than the bypass value, it will be displayed immediately, with no filtering occurring. The number represents percent of full-scale. No effect if filter = 0.																														
40023	22 (0016)	Filter	Read Write	0, 2 to 199	Integer	03, 04, 06, 16	Display filtering. 0 = no filtering. New = old + ((new - old)/Filter)																														
40024 – 40025	23 – 24 (0017 – 0018)	Cutoff	Read Write	0 to 999999	Long	03, 04, 16	Represents the display value without the decimal point. A value of 000000 disables the cutoff.																														
40026	25 (0019)	Serial Settings	Read Write	Not applicable	Integer; bits	03, 04, 06, 16	See Bit Assignment Table 3.																														
40027	26 (001A)	Unit Address	Read Write	1 to 247	Integer	03, 04, 06, 16	Master mode: the address of the slave being read. Slave mode: the PD865's address.																														
40101 To 40107	100 – 101 (0064 – 0065) 102 – 103 (0066 – 0067) 104 (0068) 105 (0069) 106 (006A)	Set-point Reset-point Turn-on delay Turn-off delay Mode	Read Write	-199999 to 999999 (Set & Reset) 0 to 199 0 to 199 Bits 4, 2, 1, 0	Long Long Integer Integer Word; bits	03, 04, 16 ----- 03, 04, 06, 16	Relay 1 parameters. Set and reset points represent the display value without the decimal point. See Bit Assignment Table 4 for operating modes and bit assignments.																														
40108 To 40114	107 – 108 (006B – 006C) 109 – 110 (006D – 006E) 111 (006F) 112 (0070) 113 (0071)	Set-point Reset-point Turn-on delay Turn-off delay Mode	Read Write	-199999 to 999999 (Set & Reset) 0 to 199 0 to 199 Bits 4, 2, 1, 0	Long Long Integer Integer Word; bits	03, 04, 16 ----- 03, 04, 06, 16	Relay 2 parameters. Set and reset points represent the display value without the decimal point. See Bit Assignment Table 4 for operating modes and bit assignments.																														

Register ¹		Name	Access	Limits or Range ²	Data Type ³	Function Code(s)	Comments
Number	Address (hex)						
40115 To 40121	114 – 115 (0072 – 0073) 116 – 117 (0074 – 0075) 118 (0076) 119 (0077) 120 (0078)	Set-point Reset-point Turn-on delay Turn-off delay Mode	Read Write	-199999 to 999999 (Set & Reset) 0 to 199 0 to 199 Bits 4, 2, 1, 0	Long Long Integer Integer Word; bits	03, 04, 16 ----- 03, 04, 06, 16	Relay 3 parameters. Set and reset points represent the display value without the decimal point. See Bit Assignment Table 4 for operating modes and bit assignments.
40122 To 40128	121 – 122 (0079 – 007A) 123 – 124 (007B – 007C) 125 (007D) 126 (007E) 127 (007F)	Set-point Reset-point Turn-on delay Turn-off delay Mode	Read Write	-199999 to 999999 (Set & Reset) 0 to 199 0 to 199 Bits 4, 2, 1, 0	Long Long Integer Integer Word; bits	03, 04, 16 ----- 03, 04, 06, 16	Relay 4 parameters. Set and reset points represent the display value without the decimal point. See Bit Assignment Table 4 for operating modes and bit assignments.
40301	300 (012C)	4-20mA out – Mode	Read Write	Not applicable	Integer; bits	03, 04, 06, 16	Selects output option and where the data source for the 4-20mA output. See Bit Assignment Table 5.
40302	301 (012D)	4-20mA out – Overrange value	Read Write	0 to 23999	Integer	03, 04, 06, 16	Corresponds to 0.000 to 23.999 mA. Because of hardware variations, the actual output range is designed to be at least 1.000 to 23.000 mA.
40303	302 (012E)	4-20mA out – Underrange value	Read Write	0 to 23999	Integer	03, 04, 06, 16	Corresponds to 0.000 to 23.999 mA. Because of hardware variations, the actual output range is designed to be at least 1.000 to 23.000 mA.
40304	303 (012F)	4-20mA out – Maximum value allowed	Read Write	0 to 23999	Integer	03, 04, 06, 16	Corresponds to 0.000 to 23.999 mA. Because of hardware variations, the actual output range is designed to be at least 1.000 to 23.000 mA.
40305	304 (0130)	4-20mA out – Minimum value allowed	Read Write	0 to 23999	Integer	03, 04, 06, 16	Corresponds to 0.000 to 23.999 mA. Because of hardware variations, the actual output range is designed to be at least 1.000 to 23.000 mA.
40306	305 (0131)	4-20mA out – Comm. Break value	Read Write	0 to 23999	Integer	03, 04, 06, 16	Corresponds to 0.000 to 23.999 mA. Because of hardware variations, the actual output range is designed to be at least 1.000 to 23.000 mA.
40307 – 40308	306 – 307 (0132 – 0133)	4-20mA out – Display Value 1 4-20mA out – Display Value 2	Read Write	-199999 to +999999	Long	03, 04, 16	4-20mA output scaling. Represents the display value without the decimal point.
40309 – 40310	308 – 309 (0134 – 0135)	4-20mA out – Display Value 1 4-20mA out – Display Value 2	Read Write	-199999 to +999999	Long	03, 04, 16	4-20mA output scaling. Represents the display value without the decimal point.
40311	310 (0136)	4-20mA out – Output 1	Read Write	0 to 23999	Integer	03, 04, 06, 16	4-20mA output scaling. mA output at Display Value 1.
40312	311 (0137)	4-20mA out – Output 2	Read Write	0 to 23999	Integer	03, 04, 06, 16	4-20mA output scaling. mA output at Display Value 2.
40313	312 (0138)	4-20mA out – Data in mA or Data in bits	Read Write	0 to 23999 or 0 to 65535	Integer	03, 04, 06, 16	If 4-20mA output mode is set to "Serial Comm., mA" (0x83) this register is in µA. Due to hardware variations, the actual output range is at least 1.000 to 23.000 mA. If 4-20mA output mode is set to "Serial Comm., bits" (0x84), this register is in DAC bits. See Bit Assignment Table 5.
40314 – 40315	313 – 314 (0139 – 013A)	4-20mA out – DAC calibration: Gain	Read Write	Dependent on hardware. Ideal = 2.85.	Float	03, 04, 16	4-20mA output gain calibration factor to convert mA to DAC counts.
40316 – 40317	315 – 316 (013B – 013C)	4-20mA out – DAC calibration: Offset	Read Write	Dependent on hardware. Ideal = 0.	Float	03, 04, 16	4-20mA output offset calibration factor to convert mA to DAC counts.
40401 – 40402 to 40431 – 40432	400 – 401 (0190 – 0191) to 40431 – 40432 (01AE – 01AF)	Input 1 to Input 16	Read Write	-199999 to 999999	Long	03, 04, 16	Input values for the scaling of 2 to 16 data points. Number of points set in Register 40015.
40433 – 40434 to 40463 – 40464	432 – 433 (01B0 – 01B1) to 462 – 463 (01CE – 01CF)	Display 1 to Display 16	Read Write	-199999 to 999999	Long	03, 04, 16	Display values for the scaling of 2 to 16 data points. Number of points set in Register 40015.
49101 To 49104	9100 – 9103 (238C – 238F)	Product Identifier	Read Only	Not applicable	ASCII characters	03, 04	8 characters indicating the product firmware number
49105 To 49108	9104 – 9107 (2390 – 2393)	Firmware Version	Read Only	Not applicable	ASCII characters	03, 04	8 characters indicating the firmware version number
49109 To 49116	9108 – 9115 (2394 – 239B)	Mfg. Serial Number	Read Only	Not applicable	ASCII characters	03, 04	16 (max) characters indicating the manufacturing serial number information.

Snooper PD865 Typical Installation Diagrams

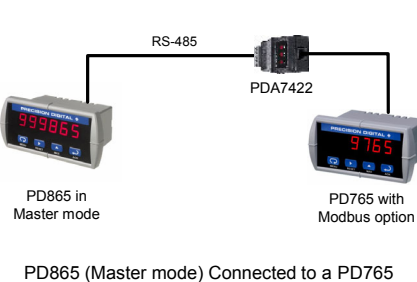
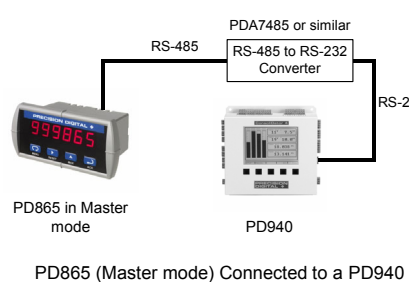
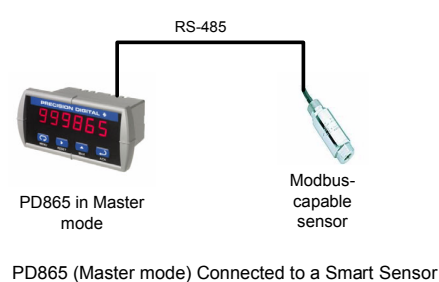
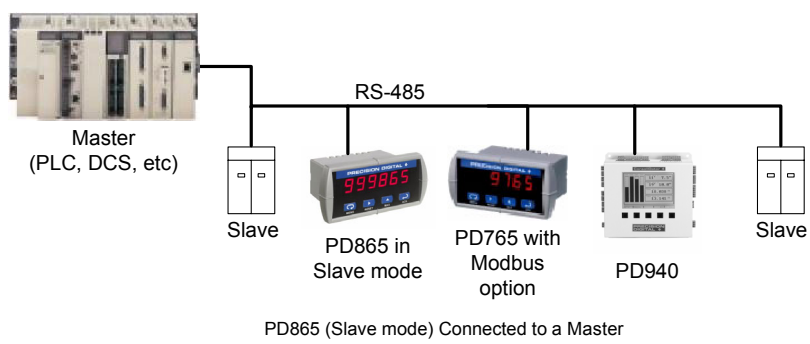

LM8865QS_A
SFT026 Ver 1.0 & up
03/05

PRECISION DIGITAL CORPORATION
19 Strathmore Road Natick MA 01760 USA
Tel (800) 343-1001 Fax (508) 655-8990

