

## Lumiglas Luminaire Series USL 07

- for use with sightglass fittings -

**ISO 9001**

DATA SHEET 02-0180 08/02

### Application:

This compact, powerful luminaire can be used for integral light/sight port (single flange version) or separate light and sight ports (dual flange version) to illuminate the internals of visual flow indicators, pipelines, laboratory mixers and other vessels and reactors which are normally closed. This model is intended for use in all Non Hazardous Areas. The unit is suitable for food processing. The luminaire must never be inserted into a vessel wall as a sealing element, i.e. without appropriate sightglass disc and fitting.

### Sightglass Styles:

This powerful, compact size luminaire is designed to give glare free illumination in combination with sightglass styles as the following:

- bolted circular flanges Model DIN 28120 or similar styles
- circular screwed flanges Series MV DN 100 and larger
- visual flow indicators (tubular or flat glass)
- sanitary clamp connection, 3" and larger

### Size:

The luminaire is mostly suitable for sightglasses DN 50 and larger.

### Protection:

Dust and waterjet proof to IP 65, EN 60529, and NEMA 4.

### Ambient Condition Operating Range:

This unit is suitable for ambient temperatures of 80°C at the cable gland. It is independent of internal vessel pressure or vacuum. When ambient temperature exceeds 40°C, consult factory when ordering. Temperature resistant cable is necessary.

### Power supply:

The unit can be fitted with various halogen lamps, and thus is suited for AC or DC voltage.

- without built-in transformer
  - supply 24 V; halogen lamp 50 W or 100 W
  - supply 230 V; halogen lamp 50 W or 100 W
  - supply 120 V; halogen lamp 35 W, 50W or 100 W
- with built-in transformer
  - supply 230 V; halogen lamp 12V/20 W

### Lamp sockets:

see table on following page

### Transformers:

Transformers with 12V or 24 V secondary voltage are optionally available

### Additions:

- DN 50 to DN 125 for light ports only
- DN 125 to DN 200 for single flange light/sight ports
- special claw spanner: for opening/tightening the lens ring
- installed automatic delay switch Lumiglas Timer, 5 minutes of operation time

**For Installation Instructions please see page 3**



Lumiglas USL 07 with fastenings



Lumiglas USL 07 installed on a circular sightglass DIN 28120

## Dimensions and Connection Data for Lumiglas Luminaire type USL 07

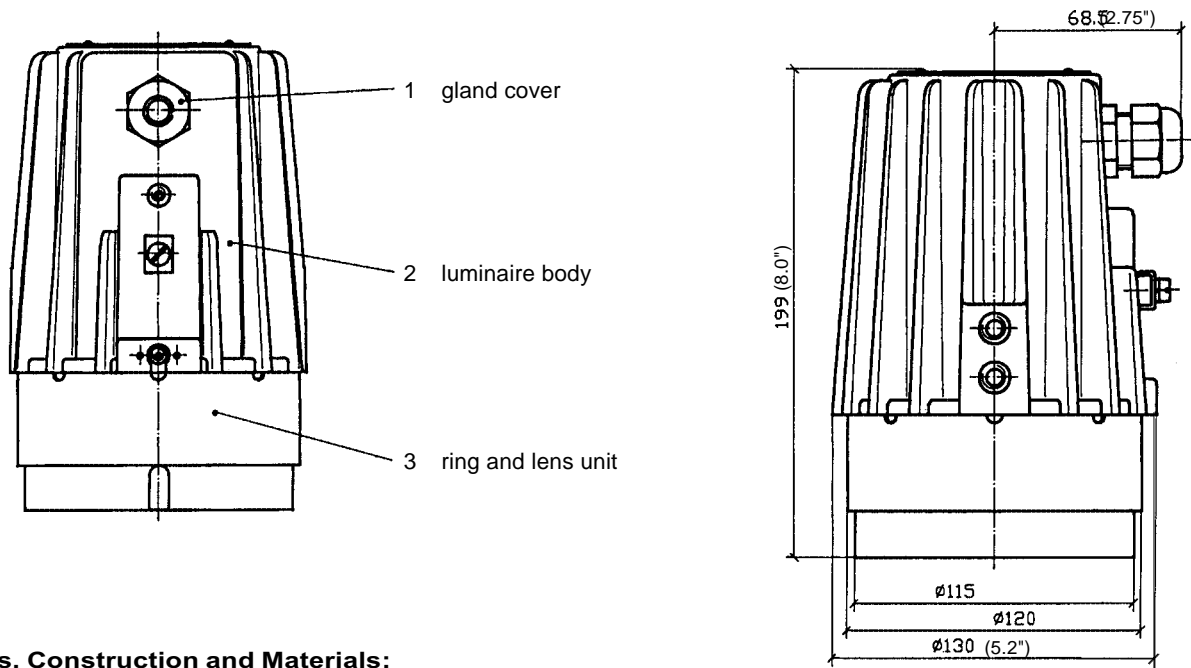

### Parts, Construction and Materials:

- Luminaire body: Corrosion resistant die cast aluminium, G-Al Si 10 Mg
- Light window: Unit of aluminium ring, glass, rubber ring seal
- Fastenings: See under "Spares", G-Al Si 10 Mg
- Weight: 4.5 lb. (ex power supply cable), 6.5 lb. with built-in transformer

Pos.	Type USL-07		Part Number	Supply Voltage	Built-in Transformer	Halogen Lamp		
						Socket	Power Intake	Part Number
1	24V	50W	3540.604.00	24	no	GY6.35	24 V / 20 W Ax	3232.242.00
2	230V	50W	3540.607.00	230	no	E27	230 V / 50 W	3232.241.00
3	230/12V	50W	3540.614.00	230	yes	GY6.35	12 V / 50 W Ax	3232.238.00
4*	120V	35W		120	no	E26	120 V / 35 W	BLB N35 E26S
5*	120V	50W		120	no	E26	120 V / 50 W	BLB N50 E26S
6*	120V	100W		120	no	E26	120 V / 100 W	BLB N100 E26F
8	24V	100W	3540.631.00	24	no	GY6.35	24 V / 100W Ax	3232.244.00
9	230V	100W	3540.634.00	230	no	E27	230 V / 100W	3232.247.00

\* Use in ambient temperature environment less than 100°F

**LJSTAR**

**INCORPORATED**

PO Box 1116 • Twinsburg, OH 44087 • (330) 405-3040 • Fax 405-3070

E-mail: [view@ljstar.com](mailto:view@ljstar.com) • Website: [www.ljstar.com](http://www.ljstar.com)

## USL 07 Installation Instructions

### General:

The unit is usually bolted by twin brackets to the sightglass assembly, i.e. to the cover flange of a bolted circular sightglass or a through flow indicator or to the slotted cover nut of a screwed flange sight-glass.

Lumiglas USL 07 can be used for the following sightglass sizes and larger:

- bolted circular flanges Model DIN 28120, DN 50
- circular screwed flanges Bolt-On Type, DN 50
- visual flow indicators, DN 50
- circular screwed flanges Series MV DN 100 or larger
- sanitary clamp connection, 3" and larger

### Electrical Connection:

- the cable should be suitable for the ambient conditions, for low voltage and the selected power
- ensure that the cable outside diameter matches the gland cover nut and seals
- use the special claw spanner to loosen the lens ring 3 and remove lens ring
- loosen the gland cover nut 1
- insert gland through opening, ensure that the outer cable sheath protrudes well into the housing and that the rubber grommet is in position
- connect the bared leads properly to the ceramic terminal block inside the luminaire and tighten gland cover nut 1
- when closing the luminaire, ensure that the rubber ring seal has been inserted properly into the groove of the luminaire body
- tighten lens ring 3 firmly with special spanner

### Lamp Change:

- switch off the luminaire and disconnect the power supply
- use the special claw spanner to loosen the lens ring 3 and remove lens ring
- replace halogen lamp, ensure bare fingers do not touch the glass, lamps with E26 and E27 socket are screwed in, the other types have two pins and are plugged into the socket
- refit lens ring, tighten firmly with special spanner
- reconnect power

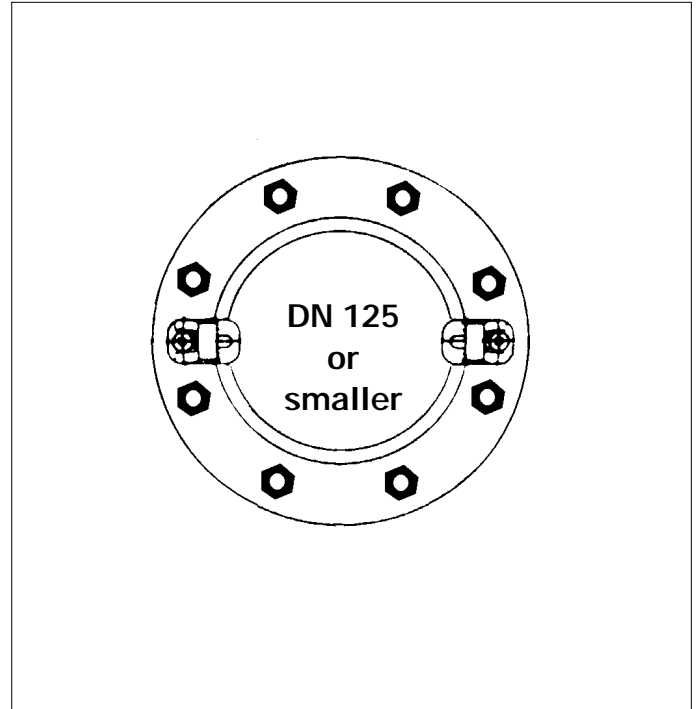

Lumiglas USL 07 light port installation on twin bracket fastenings, suitable for fittings DN 50 to DN 125. The sight port is then formed by a separate fitting

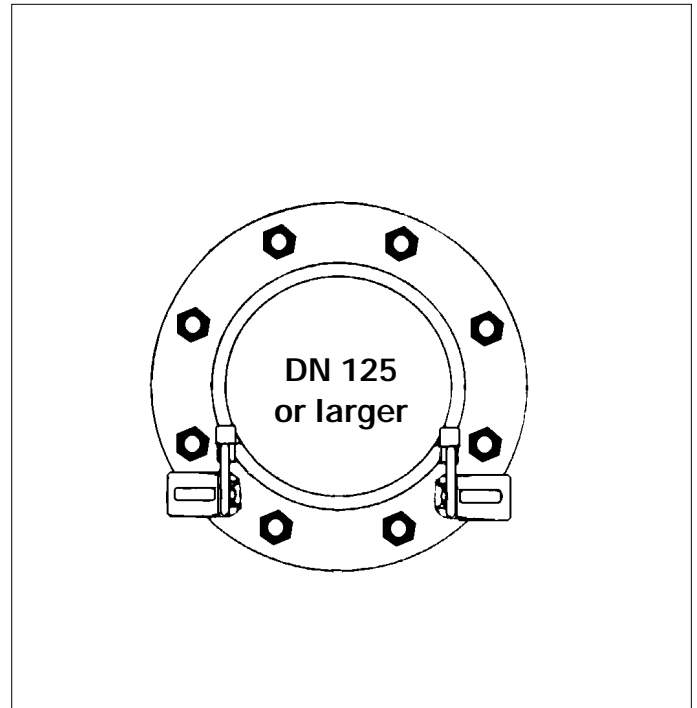

Lumiglas USL 07 installation on a combined light/sight port. These fastenings are suitable for fittings DN 125 to DN 200.

## Spares

Item .....	No
- lamp mounting straight bracket (DN 50 - 125) .....	BRK EXO8 S
- lamp mounting angular bracket (DN 125 - 200) ..	BRK EXO8 A
- Lumiglas Timer .....	factory installed
- lens and ring unit .....	1774.066.00
- reflector (spot type) .....	5904.049.00
- reflector (spot type) .....	5904.050.00
- "0" ring (Viton) .....	0862.040.00
- special claw spanner (for lens ring) .....	6805.002.00
- lamp sockets	
- GY6.35 (2-pin) .....	1202.012.00
- E 26 .....	
- E 27 .....	1202.019.00
- halogen lamps .....	see table overleaf

## Additions

### Automatic switches

Automatic switches offer several advantages:

- reduced energy consumption
- reduced maintenance
- increased lamp life

### Lumiglas Timer



The Lumiglas Timer comes installed inside the luminaire housing. Its light operation time is set to 5 minutes "ON"-mode.

### Automatic time delay module esp. for Ex applications



Timer module with "perma-  
nent" option N° 3908.012.00

Standard timer module  
N° 3908.011.00

Please read the enclosed instructions thoroughly  
All dimensions in mm unless stated otherwise  
Subject to change without prior notice

ISO 9001 QA CERTIFICATE  
GERMAN MANUFACTURER:  
F.H. PAPANMEIER AWARDED QA APPROVAL CERTIFICATE



"Ex" type timer modules, installed in the power supply line. Also available with "permanent" switch and with "central power off" mode, can be used in explosion hazardous areas. Such electronic timer modules do not require extra wiring. Available for 24V and for 230V supply power.

# LJSTAR

INCORPORATED

PO Box 1116 • Twinsburg, OH 44087 • (330) 405-3040 • Fax 405-3070

E-mail: [view@ljstar.com](mailto:view@ljstar.com) • Website: [www.ljstar.com](http://www.ljstar.com)