



Leader in
Level Measurement

For Assistance Call 1-800-527-6297
Outside North America + 215-674-1234

Installation and Operating Instructions

Series Z0X-2
Z-tron III™ Level Control

*+ 215-674-1234 Outside North America
1-800-553-9092 US and Canada
www.drexelbrook.com
drexelbrook.service@ametek.com*

AMETEK Drexelbrook makes no warranty of any kind with regard to the material contained in this manual, including, but not limited to, implied warranties or fitness for a particular purpose. Drexelbrook shall not be liable for errors contained herein or for incidental or consequential damages in connection with the performance or use of material.

Copyright 2006 AMETEK Drexelbrook

EDO# 4-06-247
Z0X-2-LM
Issue# 5

Series Z0X-2 Z-tron III™ Level Control



AMETEK®
DREXELBROOK

An ISO 9001 Certified Company

205 Keith Valley Road, Horsham, PA 19044
US and Canada: 1-800-553-9092
International: +1 215-674-1234
24-Hour Service: +1 215-527-6297
Fax: +1 215-674-2731
E-mail: drexelbrook.info@ametek.com
Website: www.drexelbrook.com

Table of Contents

Section 1:	Introduction	1
1.1	System Description	1
1.2	Technology	1
1.3	Model Number	2
Section 2:	Installation	3
2.1	Unpacking	3
2.2	Mounting the Level Control	3
2.3	Mounting Dimensions	5
2.4	Power Wiring	6
2.5	Relay Wiring	8
Section 3:	Operation	9
3.1	Setpoint Control	9
3.2	Time Delay Control	9
3.3	Time Delay Action	10
3.4	Failsafe	10
3.5	Start-up	10
Section 4:	Calibration	11
4.1	Calibration in Conducting Material	11
4.2	Calibration in Insulating Material [Horizontal Mount]	11
4.3	Calibration in Insulating Material [Vertical Mount]	12
Section 5:	Troubleshooting	13
5.1	Introduction	13
5.2	Testing Electronic Unit	13
5.3	Testing Sensing Element	13
5.4	Testing Relay Circuits	15
5.5	Possible Problems and Causes	16
5.6	Factory Assistance	17
5.7	Field Service	17
5.8	Customer Training	17
5.9	Equipment Return	18
Section 6:	Specifications	19
Appendix A:	Shortening or Lengthening the Sensing Element	A-1

Section 1: Introduction

These instructions are for the AMETEK Drexelbrook Z-tron III™ Series Point Level Control.

The label on top of the electronic unit identifies the model number of the Z-tron III level control.

If the model number on the electronic unit is a 402-3000, the instructions are included in the 502-3000-LM Instruction Manual. Both of these manuals can be downloaded from our resource library at www.Drexelbrook.com

1.1 System Description

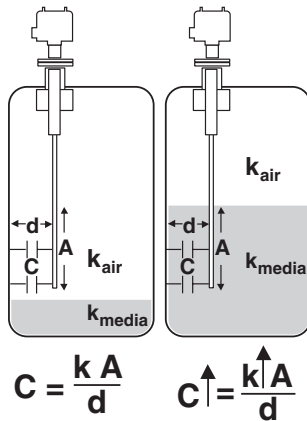

Figure 1-1
Capacitance Probe
(Insulating Media)

Cote-Shield™ action is designed into all Z-tron III level controls and enables the instrument to ignore the effect of buildup or material coating on the sensing element.

The electronic unit:

- Provides double-pole double-throw dry relay contact closure when material reaches a specific point on the sensor. The relay contacts may be used to operate alarms, solenoid valves, or other low power devices.
- Provides a 0-60 second time delay for agitated vessels.

The 700-series sensing element:

- Is mounted on the tank or in the process.
- Provides a change in radio frequency (RF) admittance indicating presence or absence of material.

1.2 Technology

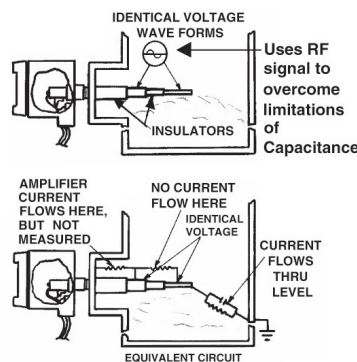

Figure 1-2
RF Admittance Probe
with Cote-Shield

In a simple capacitance probe type sensing element, when the level rises and material covers the probe, the capacitance within the circuit between the probe and the medium (conductive applications) or the probe and the vessel wall (insulating applications) increases. This is due to the dielectric constant (k) of the material, which causes a bridge misbalance. The signal is demodulated (rectified), amplified and the output is increased. There are drawbacks, however, especially when there is coating of the probe.

An RF Admittance level transmitter is the next generation. Although similar to the capacitance concept, The Z-tron employs a radio frequency signal and adds the Cote-Shield™ circuitry within the Electronics Unit.

This patented Cote-Shield™ circuitry is designed into Z-tron series and enables the instrument to ignore the effect of buildup or material coating on the sensing element. The sensing element is mounted in the vessel and provides a change in RF admittance indicating presence or absence of material.

The Cote-Shield™ element of the sensor prevents the transmission of RF current through the coating on the sensing element. The only path to ground available for the RF current is through the material being measured.

The result is an accurate measurement regardless of the amount of coating on the probe, making it by far the most versatile technology, good for very wide range conditions from cryogenics to high temperature, from vacuum to 10,000 psi pressure, and works with all types of materials.

1.3 Model Number

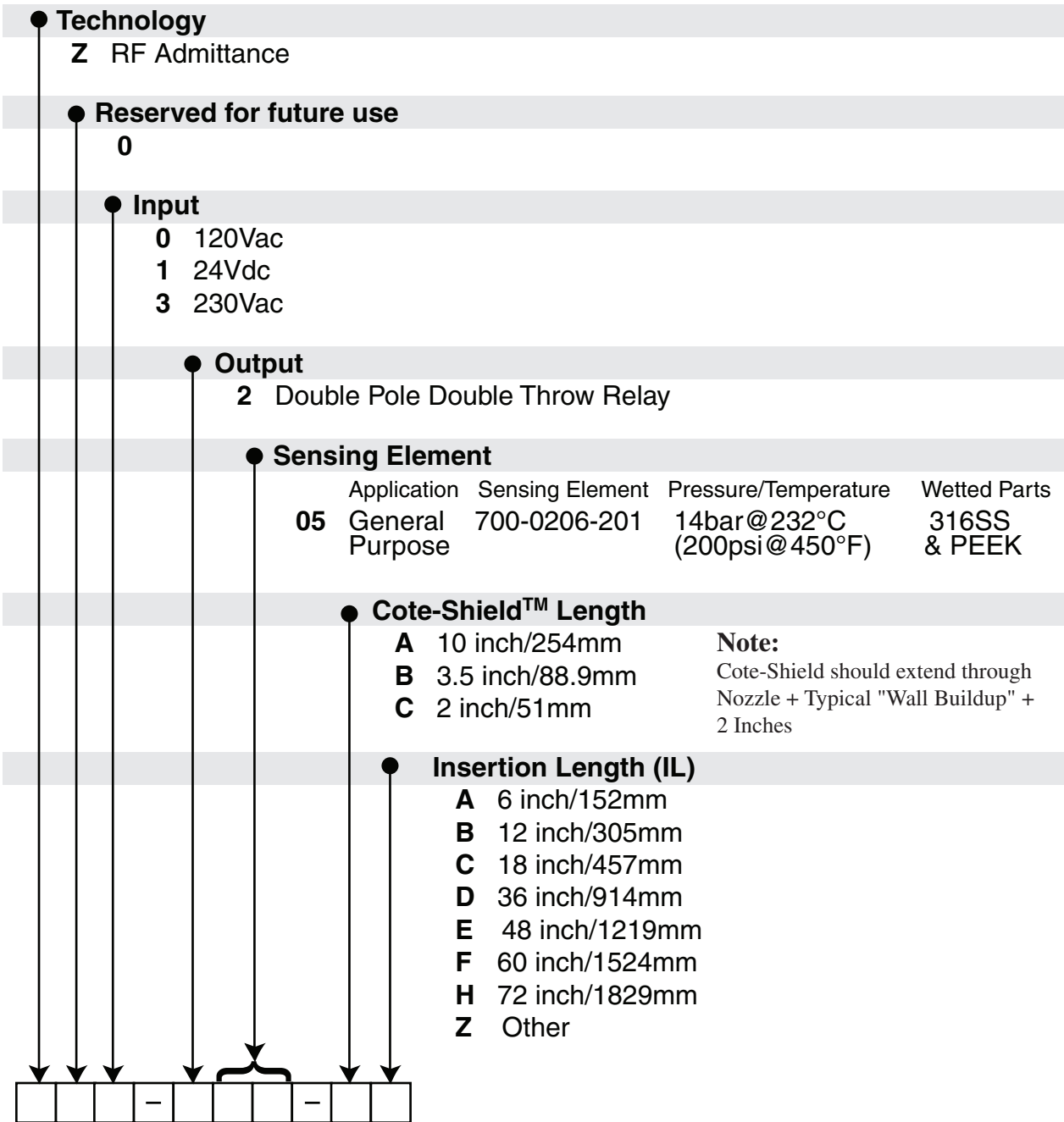

Section 2: Installation

2.1 Unpacking

Carefully remove the contents of the shipping carton and check each item against the packing list before destroying any packing materials. If there is any shortage or damage, report it to the factory at 1-800-527-6297 (US and Canada) or + 215-674-1234 (International).

2.2 Mounting the Level Control

The Z-tron III Level Control is available with the electronic unit and sensing element as a single integral assembly. Extended sensing element lengths and special mountings can be provided to fit specific applications.

- The Z-tron III Level Control is designed for industrial applications, but it should be mounted in a location as free as possible from vibration, corrosive atmospheres, or any possibility of mechanical damage.
- For convenience when adjusting, place the electronic unit in a reasonably accessible location. Ambient temperature should be between -40°F and 145°F (-40°C to 63°C).
- It may be mounted either vertically or horizontally. See Figures 2-1 and 2-2.
- Avoid mounting closer than 1 inch to any tank structure. Material bridging from structure to sensing element can cause false alarms. Close proximity to tank structure also increases the sensing element's standing capacitance.
- When installing flange-mounted sensing elements, keep mating surfaces and bolts free of paint and corrosion to ensure proper electrical contact with vessel. Avoid using excessive amounts of TFE tape when installing threaded sensing elements.
- The actual mounting location often depends on the placement of nozzles or openings into the vessel. Do not mount the instrument through a nozzle which exceeds the Cote-Shield element on the sensing element. See Figure 2-1.
- Protect the insulation on the sensing element against cuts and scrapes during installation.

Figure 2-3 provides typical mounting dimensions.

2.3 Mounting Dimensions

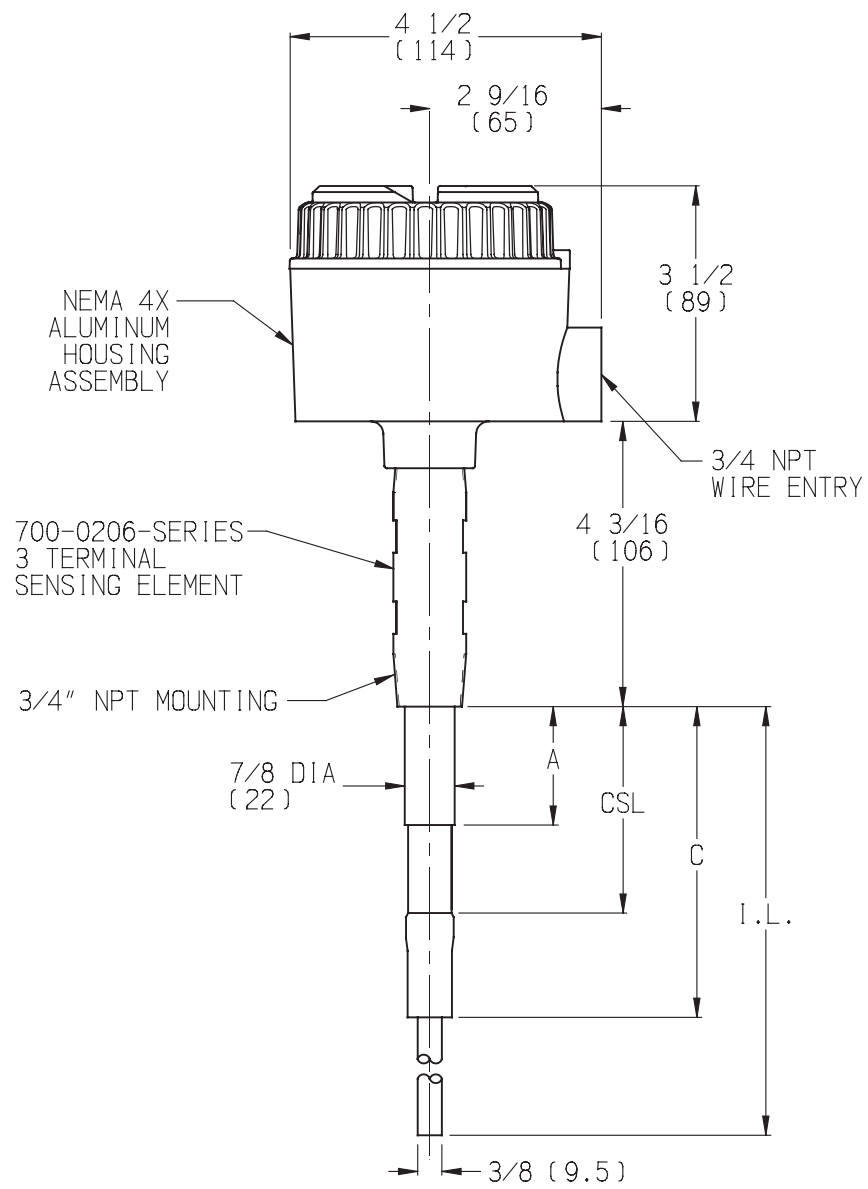
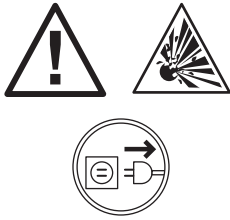

Figure 2-3
Mounting Dimensions, Integral Z-tron III Level Control

2.4 Power Wiring



CAUTION

Do not open enclosure cover or make/break any electrical connections without first disconnecting electrical power at the source. Ensure that area is non-hazardous. Ensure that wiring, electrical fittings and conduit connections conform to electrical codes for the specific location and hazard level.

The Z-tron III level control is a general purpose device and is not agency approved for use in hazardous locations. If agency approval is required, contact your local AMETEK Drexelbrook representative or call 1-800-553-9092.

Refer to Figures 2-5 through 2-7 for the appropriate power wiring and use the following procedure to wire the Z-tron III level control:



1. Ensure that all power to the wiring is off.
2. Remove the cover.
3. The power connections are made to terminals 1, 2, and 3 on the electronic chassis as shown in Figures 2-5 through 2-7, using 12-28 gauge wire. The Z-tron III level control requires at least 1 watt of power.
4. The alarm relays are wired as shown in Figure 2-8.
5. Review Checklist:
 - a. Wiring correct.
 - b. Input voltage matches instrument label.
 - c. Proper output connections.
6. Replace the cover prior to restoring power if in a hazardous area.



7. Turn power on.

2.4 Power Wiring (continued)



Use 12-28 gauge wire.

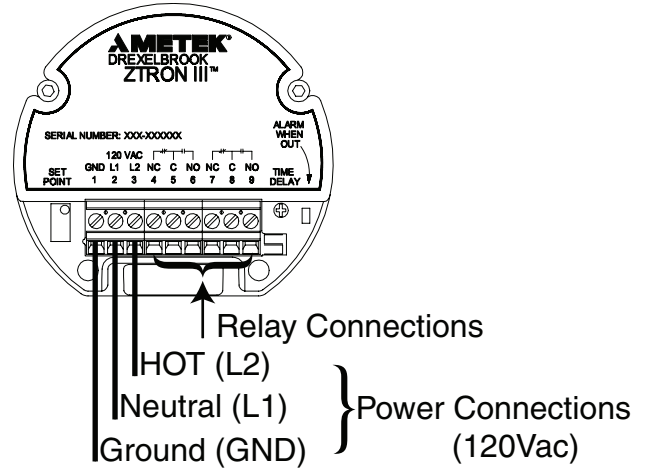

Figure 2-5
Wiring the (120 VAC) Electronic Unit



Use 12-28 gauge wire.

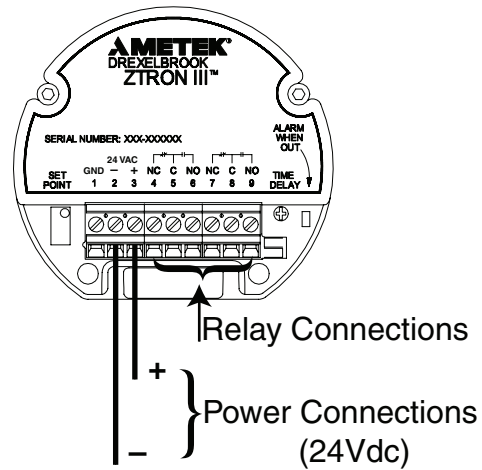

Figure 2-6
Wiring the (24 VDC) Electronic Unit



Use 12-28 gauge wire.

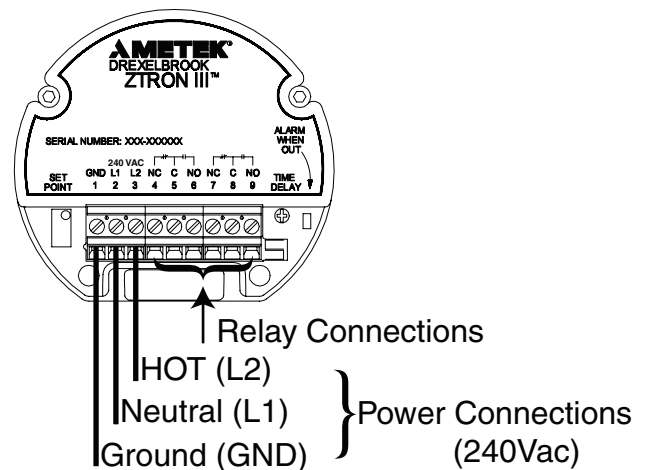

Figure 2-7
Wiring the (240 VAC) Electronic Unit

2.5 Relay Wiring

Refer to Figure 2-8 for the relay contact wiring. The Z-tron III relay has double-pole, double-throw (DPDT) dry contacts. The relay serves as a switch and does not provide the power to operate an annunciator or other equipment. All relay connections are made to the terminal strip on the electronic unit.

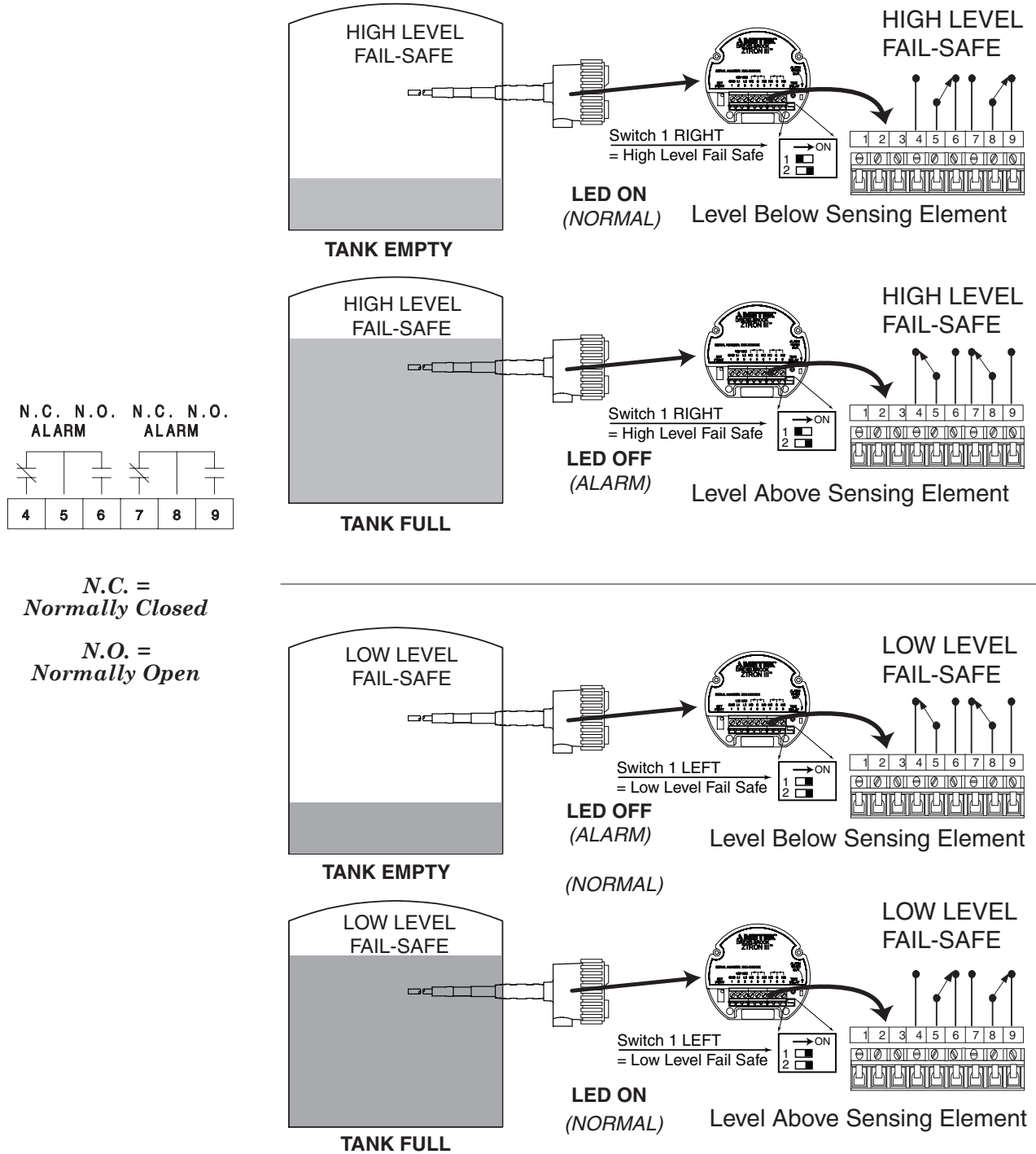

Figure 2-8
Wiring the Relays

Section 3: Operation

This section describes the operating switches of the Z-tron III level control. Remove the dome lid and use a small screwdriver to set the operating controls.

3.1 Setpoint Control

There is a single operating point adjustment used to control the level at which the relay operates. See Figures 2-8 & 3-1.



This adjustment is an 20-turn potentiometer and does not have a mechanical stop. When in High Level Fail Safe condition, if light (LED) is ON - turn CCW to find SP (relay changes state w/click & light turns OFF)... turn CW if light is initially OFF. Opposite is true in Low Level Fail Safe.

- Turning the setpoint adjustment clockwise (CW) raises the level at which the relay operates.
- Turning the setpoint counterclockwise (CCW) lowers the level at which the relay operates.
- The LED (on) indicates that the relay is energized.

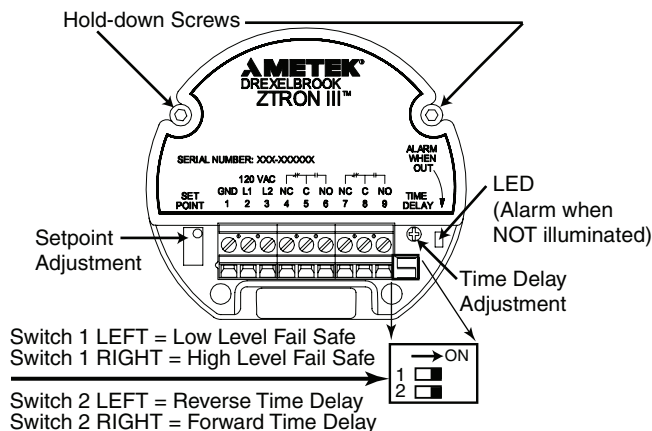

Figure 3-1
Z-tron III Operating Controls and LED

3.2 Time Delay Control

The time delay adjustment is located on top of the instrument, as shown in Figure 3-1. It is used to help stop an oscillating relay output due to agitation or waves in the vessel.



CAUTION:

THIS adjustment is a 270° (¾ turn) potentiometer. Do not turn it beyond its mechanical stops or damage to unit may occur.

The unit is shipped with the Time Delay set to zero (0) seconds. Using a small screwdriver, turn the adjustment clockwise to set anywhere from 0 to 60 seconds.

3.3 Time Delay Action

Time delay action describes whether the relay contacts are delayed from going into the alarm state or recovering from an alarm state.

- **FWD:** Forward delays the system from coming OUT of alarm.
- **REV:** Reverse delays the system from going INTO alarm.
- The instrument is supplied with the time delay action set in the forward mode position.
- The time delay action may be selected in the field using the slide switch #2 located on the top of the instrument. See Figure 3-1.

Selecting Time Delay with Slide Switch #2:

Forward Acting - Switch #2 is ON, or to the RIGHT.

Reverse Acting - Switch #2 is OFF, or to the LEFT.

3.4 Failsafe

Failsafe describes the level condition which causes the output relay to de-energize, and determines the condition of the relay upon loss of power or upon the failure of most components.

- The failsafe mode may be selected in the field by changing the position of slide switch #1 located on the top of the instrument. See Figure 3-1.
- High Level Failsafe (HLFS) means the relay will de-energize when level is high, indicating high level upon loss of power. (N.O. contacts open/N.C. contacts closed)
- Low Level Failsafe (LLFS) means the relay will de-energize when level is low, indicating low level upon loss of power. (N.O. contacts open/N.C. contacts closed)
- The instrument is supplied in the failsafe mode that is requested when the order is placed. If none specified, it will be shipped as High Level Failsafe (HLFS).

Selecting Failsafe with Slide Switch #1:

High Level Failsafe (HLFS) - Switch #1 is ON, or to the RIGHT.

Low Level Failsafe (LLFS) - Switch #1 is OFF, or to the LEFT.

3.5 Start-up



Before applying power to the instrument, be sure that the power wiring is correct. *See Section 2.3.*

Section 4: Calibration

This section contains the calibration information for the Z-tron III Level Control.

CAUTION:

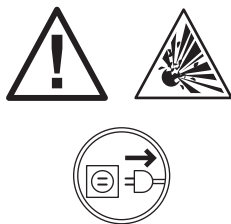

Do not open enclosure cover or make/break any electrical connections without first disconnecting electrical power at the source. Ensure that area is non-hazardous. Ensure that wiring, electrical fittings and conduit connections conform to the electrical codes for the specific location.

The Z-tron III level control is a general purpose device and is not agency approved for use in hazardous locations. If agency approval is required, contact your local AMETEK Drexelbrook representative or call 1-800-553-909

4.1 Calibration in Conducting Material



All Z-tron III controls are factory set to switch in water-based conducting materials [setpoint adjustment is set to full clockwise (CW) position]. No calibration adjustment is necessary.

If this instrument had been previously adjusted for use in a insulating materials, and is now intended for use in a conducting material, use a small screwdriver to turn the setpoint adjustment to the full clockwise (CW) position. No other adjustment is necessary.

4.2 Calibration in Insulating Material [Horizontal Mount]

Use the following procedure:

1. Be sure the material level is well below the sensing element. *See Figure 4-1.*
- 2.. Turn the setpoint adjustment to the full counterclockwise (CCW) position.



This 20-turn potentiometer does not have a mechanical stop. Turn 20 times to assure that you are at the extreme end. No damage will occur.

The LED (on) indicates that the relay is energized or in normal condition (not alarm).

3. Turn setpoint adjustment slowly clockwise (CW) until the relay just operates. (LED changes state).
4. Increase the material level until it is well above the sensing element. *See Figure 4-2.* (LED changes state).
5. Mentally note the position of the screwdriver.
6. Counting the number of turns, turn the setpoint adjustment slowly clockwise (CW) until the relay once again just operates.

4.2 Calibration in Insulating Material [Horizontal Mount]- (Continued)



If less than one turn of the adjustment was observed between the sensing element covered and uncovered, the sensor is not generating enough signal. Consult the factory for further options.

7. Turn the adjustment back counterclockwise (CCW) one half the number of turns that were counted.
8. Record number of turns and save for future calibration reference

Calibration is now complete.

4.3 Calibration in Insulating Material [Vertical Mount]



This 20-turn potentiometer does not have a mechanical stop. Turn 20 times to assure that you are at the extreme end. No damage will occur.

The LED (on) indicates that the relay is energized or in normal condition (not alarm).

1. Set the level to a point on the active section of the sensing element where control is desired (3 inches [76.2 mm] of coverage minimum). *See Figure 4-3.*
2. Start from the full counterclockwise (CCW) position. Turn the setpoint adjustment clockwise (CW) until the relay just operates (LED changes states).



If dielectric constant or conductivity of material changes, point of operation may change. Consult factory.

Calibration is now complete.

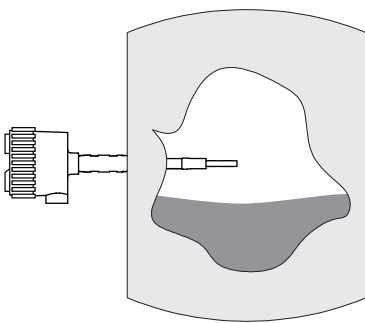

Figure 4-1
Level Below Horizontal
Sensing Element

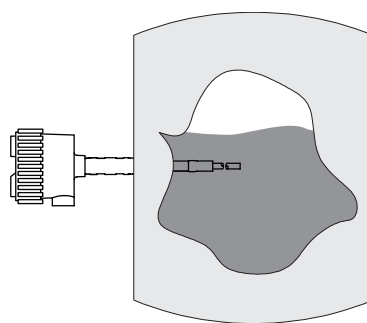

Figure 4-2
Level Above Horizontal
Sensing Element

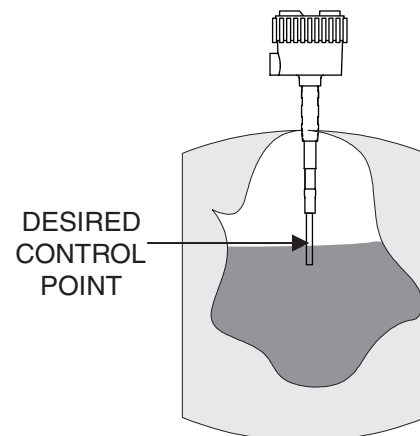

Figure 4-3
Level Covering Vertical
Sensing Element

Section 5: Troubleshooting

5.1 Introduction

The Z-tron III Level Control is a solid-state device with no moving parts other than its relays, and requires no maintenance or adjustments. The units are designed to give years of unattended service.

A spare electronic chassis is recommended for every 10 units so that, in case of a failed unit, a critical application will not be delayed while the unit is returned to the factory for repair.

Use the following troubleshooting procedures to check out the Z-tron III Level Control. If attempts to locate the difficulty fail, notify your local Drexelbrook representative, or call the factory direct at 1-800-527-6297 (US and Canada) or +1 215-674-1234 (International).

5.2 Testing Electronic Unit

It is recommended to begin with Electronic Unit:

1. Verify that voltage is reaching unit.
2. Change fail-safe selector switch (Fig 3-1). If LED does not change state along with relays, Electronic Unit has failed.

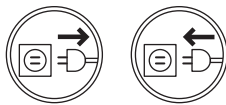

3. Remove power from unit, loosen hold-down screws, then remove unit. Remove Blue screw from top of sensing element & disconnect Red spade lug connector. SAFELY reapply power.
4. As in Section 3.1, start with setpoint adjustment in extreme counterclockwise (CCW) position, turn screwdriver clockwise (CW) until relay just operates.
5. Rotate setpoint adjustment back and forth about this point, observing travel of screwdriver between relay pull-in and relay drop-out. If properly operating, screwdriver should travel less than ¼ turn to operate the relay. If not, Electric Unit has failed.

5.3 Testing Sensing Element

Be sure to first test Electronic Unit. Then:



1. Remove Electric Unit, as above, but do not apply power.
2. Use an analog ohmmeter¹ that is set to the R x 1K ohm scale. Measure the resistances between each pair of sensing element connections. **See Figure 5-1.**

Center Conductor to Housing		ohms
Center Conductor to Red Lug		ohms
Red Lug to Housing		ohms

5.3 Testing Sensing Element (continued)

3. A new sensing element that is clean and not coated or wet should look like an open circuit on all sensing element tests.
4. If the sensing element is clean and dry, and shows resistance between terminals of less than 10K ohms, it is possible that moisture has soaked into the packing gland of the sensing element. In this case, the sensing element may need to be dried until the resistance increases to its maximum value.
5. If the process material is conductive, you may read some resistance between sensing element connections. The lowest permissible resistance values are:

Center Conductor to Housing	1000 ohms.
Center Conductor to Red Lug	600 ohms.
Red Lug to Housing	300 ohms.

6. Resistance values lower than this could mean:
 - Extremely conductive coating on probe, which is an application problem. You may wish to call the factory for suggestions for another technique.
 - Probe is damaged and needs to be replaced.
 - Probe is touching vessel.
7. A resistance reading of less than 10 ohms on any sensing element terminal is usually due to a metal-to-metal short circuit. Check that the sensing element is not touching any vessel structure.

¹An analog ohmmeter has a lower ohms/volt rating and provides more current to measure the resistance than a digital ohmmeter.

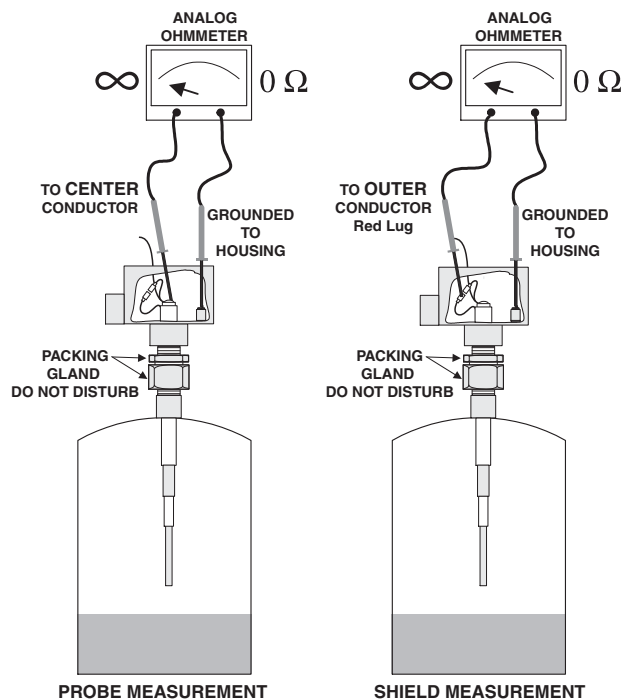

Figure 5-1
Checking the Sensing Element
 Center = Probe
 Outer = Shield
 Housing = Ground

5.4 Testing Relay Circuits

Using an ohmmeter, perform the following steps to check out the relay circuits:

1. The relay circuits consist of double-pole double-throw relay contacts brought out to terminal strips. When the relays are operating properly, one pair of contacts will be open with high or low level, and one pair will be closed with high or low level. Refer to **Figures 2-10 and 5-2**.
2. Relay operation may generally be heard as an audible click when the background noise is not too high. Use one of the methods shown in **Figure 5-3** to determine if the relay contacts are switching.
3. Difficulty in calibration can often be traced to improper wiring of the relay terminals to an annunciator or other panel device. Check the wiring against the relay chart in **Figure 2-10**.

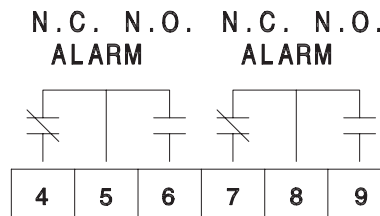

Figure 5-2
Relay Circuit Operation

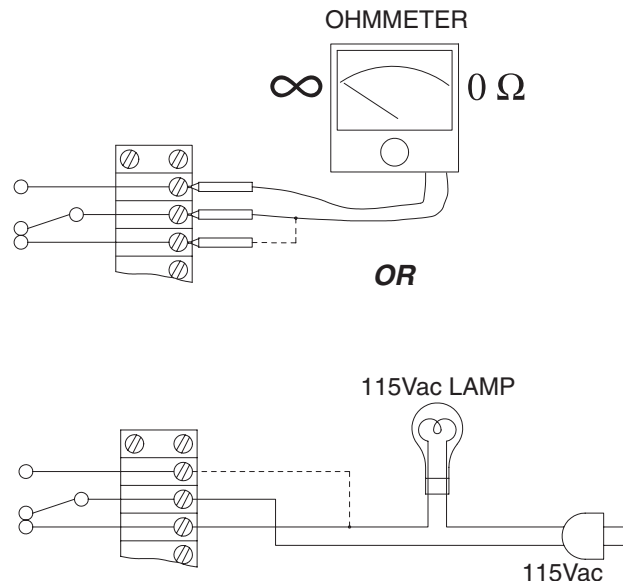

Figure 5-3
Relay Circuit Troubleshooting

5.5 Possible Problems and Causes

Problem	Possible Cause	Solution
1. Instrument indicates alarm at all times.	<ul style="list-style-type: none"> a. Severe coating build upon sensing element (HLFS). b. Sensing element not “seeing” material (LLFS) due to fill angle. c. Defect in sensing element. d. Loss of power. e. Improper relay wiring. f. Improper calibration. g. Electronic unit malfunction. h. Shorted sensor. i. Water in housing or conduit. 	<ul style="list-style-type: none"> a. Need longer Cote-Shield. Consult factory. b. Need longer insertion length. Consult factory. c. See Section 5.3. d. Check power wiring. See Figure 2-4. e. See Section 2.5. f. See Section 4. g. See Section 5.2. h. See Section 5.3. i. Consult factory.
2. Instrument never indicates alarm.	<ul style="list-style-type: none"> a. Severe coating build-up on sensing element (LLFS). b. Sensing element not “seeing” material (HLFS) due to fill angle. c. Improper wiring. d. Improper calibration. e. Electronic unit malfunction. 	<ul style="list-style-type: none"> a. Need longer Cote-Shield. Consult factory. b. Need longer insertion length. Consult factory. c. See Section 2. d. See Section 4. e. See Section 5.2.
3. Instrument can't be calibrated.	<ul style="list-style-type: none"> a. Improper wiring. b. Insufficient signal from sensing element. c. Setpoint is beyond the tuning range of the electronics. d. Electronic unit malfunction e. Sensor covered with conducting material. 	<ul style="list-style-type: none"> a. See Section 2. b. Need longer insertion length. Consult factory. c. Consult factory. e. See Section 5.2.
4. Instrument gives a false alarm.	<ul style="list-style-type: none"> a. Improper calibration. b. Loose wiring. c. Electronic unit malfunction. d. Time delay required. e. Intermittent short of sensor. 	<ul style="list-style-type: none"> a. See Section 4. b. See Section 2. c. See Section 5.2. d. Consult factory. e. See Section 5.3.
5. Instrument operates intermittently.	<ul style="list-style-type: none"> a. Improper calibration. b. Loose wiring. c. Electronic unit malfunction. d. Dielectric (k) of material is too low. 	<ul style="list-style-type: none"> a. See Section 4. b. See Section 2. c. See Section 5.2. d. Need high sensitivity unit. Consult factory.

5.6 Factory Assistance

AMETEK Drexelbrook can answer any questions about The Z-tron III series instrument. Call Customer Service at 1-800-553-9092 (US and Canada) or +1 215 674-1234 (International).

If you require assistance and attempts to locate the problem have failed:

Contact your local Drexelbrook representative,



Telephone the Service department toll-free:

- 1-800-527-6297 (US and Canada)
- +1 215 674-1234 (International)

FAX: Service Department + 215-443-5117

E-Mail: drexelbrook.service@ametek.com

Please provide the following information:

- Instrument Model Number
- Sensing Element Model Number and Length
- Original Purchase Order Number
- Material being measured
- Temperature
- Pressure
- Agitation
- Brief description of the problem
- Checkout procedures that have failed

5.7 Field Service

Trained field servicemen are available on a time-plus-expense basis to assist in start-ups, diagnosing difficult application problems, or in-plant training of personnel. Contact the service department for further details.

5.8 Customer Training

Periodically, AMETEK Drexelbrook instrument training seminars for customers are held at the factory. These sessions are guided by Drexelbrook engineers and specialists, and provide detailed information on all aspects of level measurement, including theory and practice of instrument operation. For more information write to: AMETEK Drexelbrook, Communications/ Training Group or call 215-674-1234.

5.9 Equipment Return

In order to provide the best service, any equipment being returned for repair or credit must be pre-approved by the factory.

In many applications, sensing elements are exposed to hazardous materials.

- **OSHA mandates** that our employees be informed and protected from hazardous chemicals.
- **Material Safety Data Sheets (MSDS)** listing the hazardous materials to which the sensing element has been exposed **MUST** accompany any repair.
- It is your responsibility to fully disclose all chemicals and **decontaminate** the sensing element.



To obtain a return authorization (RA#), contact the Service department at 1-800-527-6297 (US and Canada) or + 215-674-1234 (International).

- Please provide the following information:
- Model Number of Return Equipment
- Serial Number
- Original Purchase Order Number
- Process Materials to which the equipment has been exposed.
- MSDS sheets for any hazardous materials
- Billing Address
- Shipping Address
- Purchase Order Number for Repairs
- Please include a purchase order even if the repair is under warranty. If repair is covered under warranty, you will not be charged.

Ship equipment freight prepaid to:

AMETEK-DREXELBROOK.
205 KEITH VALLEY ROAD
HORSHAM, PA 19044-1499
COD shipments will not be accepted.

Section 6: Specifications

Power Requirements:

AC Units:

95-145 Vac, 50/60 Hz, 1 Watt

215-265 Vac, 50/60 Hz, 1 Watt

DC Units:

24 Vdc Unit: 19-29 Vdc input, 1 Watt

Sensitivity:

0.3pF or less

Operating Point Range:

0 - 80 pF (20 Turn Pot / 4 pF per Turn)

Load Resistance:

Center to Ground, 1500 ohms

Center to Shield, 750 ohms

Shield to Ground, 750 ohms

Failsafe:

Field adjustable to either High-Level Fail-Safe (HLFS)

or

Low-Level Fail-Safe (LLFS)

Output:

DPDT relay closure

Contact Rating:

5A @ 120 Vac non-inductive

2A @ 230 Vac non-inductive

Ambient Temperature:

-40°F to 145°F (-40°C to 60°C)

Temperature Effect:

0.5pF/50°F

Line Voltage Effect:

0.2pF/20V @ 120 Vac

Stability:

0.15pF/6 mo. maximum shift

Spark Protection:

100 Amp

Mounting:

¾-inch NPT standard

Section 6: Specifications (Continued)

Housing:

The standard explosionproof housing meets the following classifications:

- Nema 1 General-Purpose
- Nema 2 Drip-Tight
- Nema 3 Weather-Resistant
- Nema 4 Waterproof
- Nema 5 Dust-Tight
- Nema 12 Industrial Use

FM approved for Class I, Groups A, B, C, and D (Div. 1 or 2) and Class II, Groups E, F, and G, (Div. 1 or 2). FM approval on housing only. If agency approval is required, use the Drexelbrook PXL The Point™ instrument for point level control.

Time Delay:

0-60 seconds

Sensing Element:

Sensing Element Model Number	Process Temperature and Pressure	Process Wetted Parts	Center Rod O.D.
700-206-201	450°F @ 200 psi	316 SS and Peek	3/8 inch



Temperature at electronics must not exceed 145° F

Appendix A: Shortening or Lengthening the Sensing Element



CAUTION:
*The insulation length of either **Flush Sensing Elements** or **Insulated Sensing Elements** can **NOT** be changed. **Cable Sensing Elements** can only be shortened. Instructions are included with each unit.*

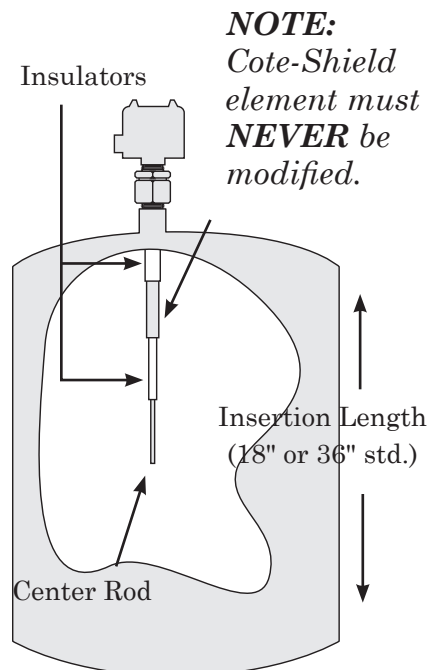

Note:
Any changes to probe length after calibration requires re calibration to ensure proper operation.

The Need

Sometimes your application calls for probe lengths other than the standard 18-inch or longer insertion lengths supplied. Shortening the sensing element is quite simple and can be done in the field. Lengthening the sensing element, however, is more difficult because the metal rod, typically 304 SS or 316 SS, must be welded.

Before making any Adjustments:

- 1) Read the following instructions thoroughly.
- 2) Remove power.
- 3) Disconnect the electronics.
- 4) Protect electronics from any static discharge.
- 5) Protect electronics from any heat.

Shortening

The bare metal center rod of the sensing element can be shortened with a hacksaw. Be careful not to cut either of the two insulators. See Figure on this page.

In applications using conductive or water-based materials, shortening is not a problem. Leave a minimum bare metal center rod length of two (2) inches.

For dry granular materials, such as powder, sand, corn, clinker, etc., you must leave a minimum bare metal center rod length of eight (8) inches. Consult the factory before shortening beyond this point.

Lengthening

To lengthen the sensing element, an extension rod can be welded onto the end of the bare metal center rod. Make sure that the extension rod is the same metal as the sensing element.

An alternate option is to add a pipe coupling and a section of metal pipe after threading the tip of the sensing element. In this case, the metal pipe need not be identical to the metal of the sensing element.

AMETEK[®]
DREXELBROOK

An ISO 9001 Certified Company

205 Keith Valley Road, Horsham, PA 19044

US and Canada: 1-800-553-9092

International: +1 215-674-1234

24-Hour Service: +1 215-527-6297

Fax: +1 215-674-2731

E-mail: drexelbrook.info@ametek.com

Website: www.drexelbrook.com