

MODEL PD118 MINIMUX® 8 CHANNEL SCANNER

The Minimux® is a microprocessor-based eight channel analog input scanner/multiplexer and annunciator that provides low cost automatic switching for multi-point display and alarm systems. Each Minimux® can automatically switch up to eight inputs to another device such as a digital panel meter, controller, or PLC. Signal switching is done with reed relays making the Minimux® ideal for switching thermocouples, RTDs, control loops, and AC & DC signals.

SPECIFICATIONS

NUMBER OF CHANNELS PER MINIMUX®: 8 double-pole channels per unit.

NUMBER OF CHANNELS PER SYSTEM: Unlimited

SIGNAL SWITCHING: DPST reed relays

CONTACT RESISTANCE: 0.2 Ω maximum

MAXIMUM INPUT VOLTAGE: 200 V (switched or common mode)

MAXIMUM CURRENT SWITCHED: 0.5 A

MAXIMUM POWER SWITCHED: 10 W

DWELL TIME (Internal-scan): Each channel adjustable from 0.6 to 30 seconds.

DWELL TIME (External-scan): Determined by external device such as a PLC or DCS, 1.5 seconds per channel minimum.

NON-VOLATILE MEMORY: All programming values are stored in non-volatile memory for ten years if power is lost.

SCAN METHOD: Internal or externally controlled (PLC, etc.)

CHANNEL SELECT/CHANNEL ID: Input Impedance; 10 KΩ pull-up to 5 V. Each channel on the Minimux® has a Channel Select/Channel ID line which is used to either select or identify a channel on the PD118. For instance, in External Scan Mode, an external device such as a PLC can drive the Channel Select/Channel ID line low for the channel it wants to see, the PD118 will then go to that channel. In Internal Scan Mode, the Channel Select/Channel ID line for the currently scanned channel goes low to provide identification of the current channel to an external device.

CHANNEL INDICATION: Green LED on front panel; Channel Select/ID line goes low.

DISABLING CHANNELS: Channels may be disabled during setup with front panel CTRL button.

SCAN STOP: The scan may be stopped by pressing and holding the CTRL button for more than 0.5 seconds. The scan may be resumed by pressing and releasing the CTRL button quickly (less than 0.5 seconds).

ALARM INPUT: Independent alarm input for each channel. Input Impedance; 25 KΩ, typical pull-up to 5V.

ALARM SEQUENCE: Sequence A or Sequence F2A (first out).

ALARM OUTPUTS: Alarm condition indicated by:

- Front panel red LED for each channel.
- Relay, 1 SPDT (form C); rated 2 Amp @ 30 VDC or 2 Amp @ 250 VAC resistive load; 1/14 HP @ 125 / 250 VAC for inductive loads. For fail-safe operation, the relay is energized in the non-alarm state. In the case of a power failure, the relay will go to the alarm state, (NC contact is connected to common).
- Built-in Horn, 75 dB
- Stop-on-alarmed-channel (user select).

ALARM ACKNOWLEDGMENT: Front panel ACK and rear connector.

EXTERNAL CTRL FUNCTION: The functions of the CTRL button are available at screw terminals at the rear of the instrument.

MESSAGE LABELS: Custom printed free of charge. Area available per message is 1.25" x .22" (32 mm x 6 mm); user may specify any size and length that will fit in this area. One line of 14 characters at 9 point type will fit.

CONNECTIONS: Removable screw terminal connectors provided.

OPERATING TEMPERATURE: -10°C to 65°C

POWER: 115 or 230 VAC (field select), ± 10%, 50/60 Hz, 4 VA; 24 VDC, ± 10%, 4 watts.

LED TEST: All LEDs are tested on power-up.

ENCLOSURE: 1/8 DIN, high impact plastic, UL94V-0, color: black.

FRONT PANEL: NEMA 4X, panel gasket provided.

WARRANTY: 1 year parts and labor.

EXTENDED WARRANTY: Warranty may be extended for an additional 12 months by returning the Product Registration Form within 2 months from date of purchase. For online registration please go to www.predig.com.

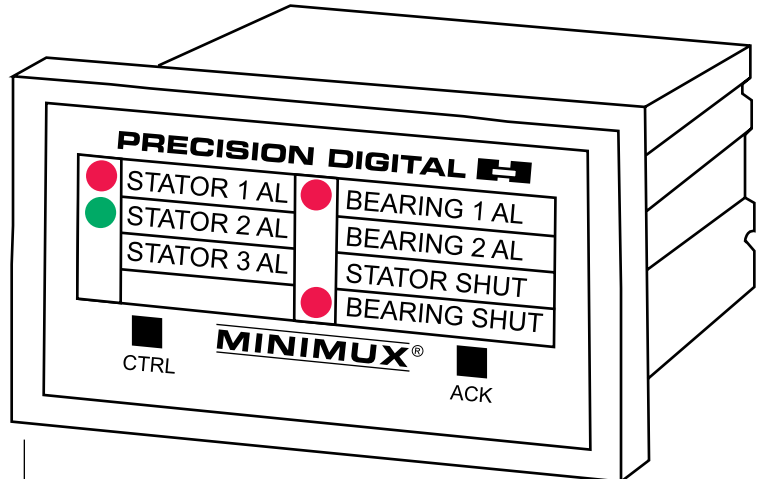

- 8 Inputs per Unit
- Unlimited Number of Units per System
- Thermocouples, RTDs, Process, AC & DC Inputs
- PLC Controllable
- Adjustable Dwell Time for Each Channel
- Independent Alarm Input for Each Channel
- FREE Custom Printed Message Labels, at any Time

ORDERING INFORMATION

Model	Description
PD118*	8 Channel Scanner/Annunciator; 115 or 230 VAC (field select)
PD118-2	8 Channel Scanner/Annunciator; 24 VDC
PD118-CL	8 Channel Scanner/Annunciator; 115 or 230 VAC (field select) with current loop resistor network installed (for 4-20 mA inputs)
PD118-2-CL	8 Channel Scanner/Annunciator, 24 VDC with current loop resistor network installed (for 4-20 mA inputs)
PDA-CL	Current Loop Resistor Network (for 4-20 mA inputs)

NOTES:

1. All AC powered units are shipped from the factory set for 115 VAC power.
2. Message labels for the PD118 may be specified at time of order or later.
3. Removable screw terminal connectors are standard on the PD118.
4. There is no special cable required to connect multiple PD118s together.

Ordering Example

A system to automatically scan and display eight type J thermocouples and check each one for alarm condition, powered from 115 VAC:

Model	Description	Quantity
PD118	8 Channel scanner/annunciator	1
PD750-3-14	Universal temperature meter with 2 relay alarm option, 115 VAC	1

*Quick Shipment Product, shipped within 2 working days.

PRECISION DIGITAL

www.predig.com

USE THE MINIMUX® FOR:

Automatic Switching

In its most basic form, the PD118 is the electrical equivalent of a double-pole, eight position automatic switch. That is, whatever input is brought into the PD118 is dwelled on for a certain amount of time while being switched back out to another device. For example, a typical application may involve switching eight type J thermocouples into a single digital panel meter.

Alarm Annunciator

One of the key features of the PD118 is its ability to indicate and process alarms that are generated by an external device such as a digital panel meter with relays or a PLC.

PLC Controllable

A PLC or other external device can control the Minimux's® dwell times, scan sequence, and alarm functions. The PLC can be programmed to make the PD118 scan any channel it wants, for as long as it wants, and in any order it wants.

Internal or External Scan Control

The PD118 has two modes for controlling the scan rate. Internal scanning programs the unit to automatically scan each selected channel. Under external scanning, an external device such as a PLC can direct which channel to scan by driving that channel's Channel Select/Channel ID line low.

Internal Scan

When a PD118 has been programmed for internal scan, it automatically scans through each active channel, dwells on that channel for the programmed dwell time, while at the same time switching the signal to an external device.

While the PD118 is on a particular channel, that channel's Channel Select/Channel ID line is driven low. This provides a convenient way for a PLC to know which channel is currently being scanned.

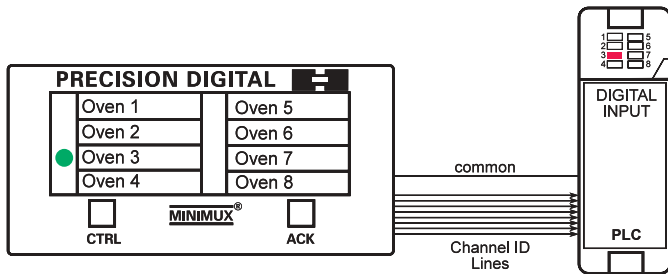

PD118 is currently scanning channel 3 and telling the PLC it is on this channel by sending Channel 3's Channel Select/Channel ID line low. All other lines are high.

External Scan

When a PD118 has been programmed for external scan, an external device such as a PLC controls the scan sequence and the dwell times. The PLC controls these two functions by sending the desired Channel Select/Channel ID line low and holding it low for as long as it wants to stay on that channel.

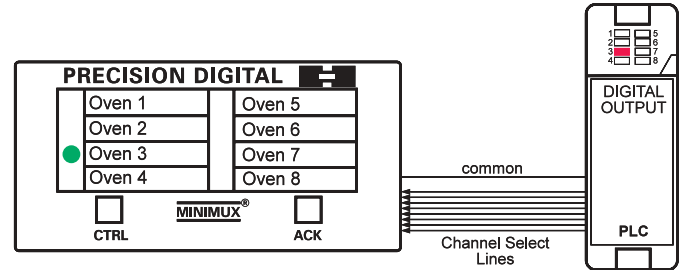

The PLC has directed the PD118 to channel 3 by sending Channel 3's Channel Select/Channel ID line low. All other lines are high.

Alarms

Each channel of the Minimux® has an independent 'Alarm-in' terminal that allows an external device to trigger an alarm on the Minimux®. The external device may be the relays on a digital panel meter, such as the PD750-3-14, or the digital output from a PLC. When an external device detects an alarm condition, it drives the appropriate Alarm-in line on the Minimux® low. When the PD118 reaches this channel, its LED will turn red and flash, the built-in horn will sound and the alarm relay will transfer.

Alarm Input Connections

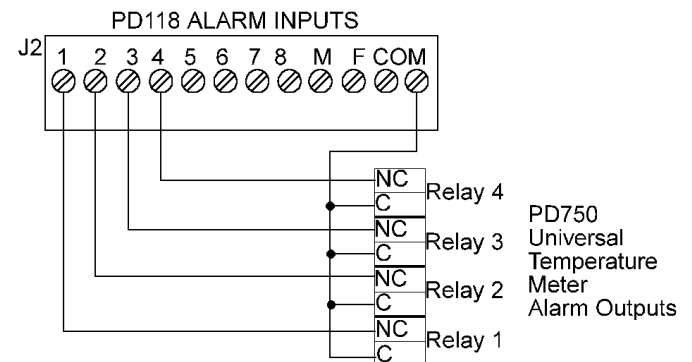

APPLICATION

Using a PD118 and a PD750 to scan 4 thermocouples

In this example, four thermocouples are being scanned by a PD750 Universal Temperature Meter and checked for independent alarm conditions.

The PD118 Minimax® is programmed in the following manner to satisfy this application:

- select internal scan
- select alarm Sequence A
- stop-on-alarm is off
- program dwell times:

channel 1 for ten seconds	channel 4 for five seconds
channel 2 for five second	channels 5-8 are disabled
channel 3 for fifteen seconds	

The PD750-3-17 is programmed in the following manner to satisfy this application:

- select thermocouple
- select Fahrenheit
- program alarm set and reset points:

#1 alarm set point 150,	reset point 145
#2 alarm set point 175,	reset point 170
#3 alarm set point 300,	reset point 295
#4 alarm set point 325,	reset point 320

The Minimax® scans each channel and is currently switching input #3 to the PD750-3-17 where thermocouple #3 is reading 250°F. Relay #3 does not detect an alarm because the temperature has not reached 300°. The Minimax® only responds to alarm conditions detected on the currently active channel, which is why relays #1 and #2 in the PD750 have transferred, but have not been detected by the PD118. The PD118 also avoids false alarms by detecting alarm conditions only after dwelling on a channel for 2 seconds or 0.05 seconds before it goes onto the next point, if dwelling on a channel for less than 2 seconds. This gives the PD750 time to stabilize and accurately display the temperature and check for alarm conditions.

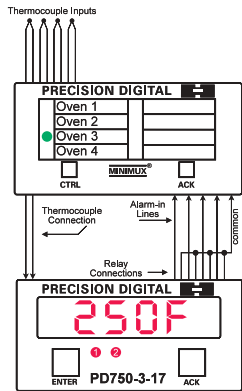

The Minimax® switches input #4 to the PD750-3-17 where a temperature of 345°F is found to be in alarm condition. Relay #4 on the PD750 transfers and after two seconds the PD118 detects this. The PD118 is programmed for Sequence A so channel #4 LED begins to flash orange, the internal horn sounds and the PD118's alarm relay transfers causing an external horn to sound.

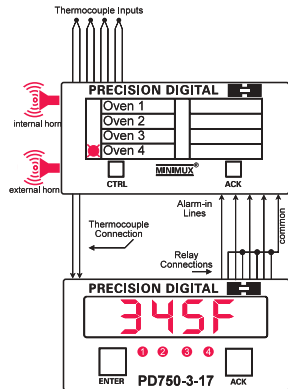

The Minimax® scan has moved to channel #2 where the temperature is 160°F. The operator acknowledges the alarm that occurred on channel #4 by pressing the ACK button on the PD118. This causes the internal and external horn to silence, and the #4 LED on the PD118 to go from flashing to steady red. Channel #4 will remain in alarm condition until the temperature for channel #4 falls below 320°F and the PD118 re-scans that channel.

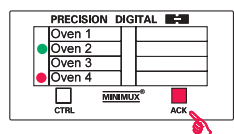

SIGNAL CONNECTIONS

Three-Wire RTD Inputs

Three-wire inputs such as thermistors and RTDs can be handled by switching the two common wires and connecting the third wire of each sensor to the RTD-TP terminal and to the temperature meter.

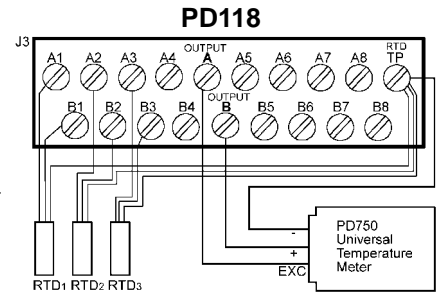

- Connect like color leads to terminals A1 & B1, A2 & B2, A3 & B3, etc.
- Connect odd color leads to terminal RTD-TP.
- Connect outputs A, B and RTD-TP to the temperature meter.

The example above shows three 3-wire RTDs multiplexed into 1 temperature meter.

Thermocouple Inputs

Thermocouple wire must be used between the Minimax® and the meter.

This example shows 3 type J thermocouples multiplexed into 1 temperature meter.

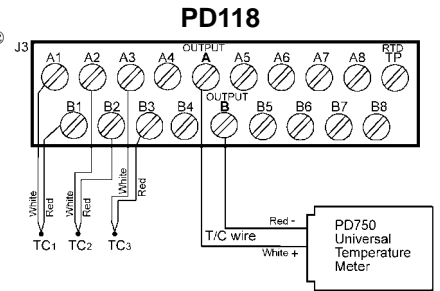

4-20 mA Inputs

A special version of the Minimax® is used to switch 4-20 mA signals. The PD118-CL, has a built-in resistor network that eliminates loop interruptions. This resistor network, model PDA-CL, may be ordered separately and field installed into existing PD118s.

The process meter must be setup for 1-5 V input and the complete system should be calibrated together.

The PD690's internal transmitter power supply may be used to power the transmitters. However, only the transmitter that is currently selected will be powered and all others will not be powered. Care should be taken to provide the transmitter with sufficient time to stabilize to provide an accurate output.

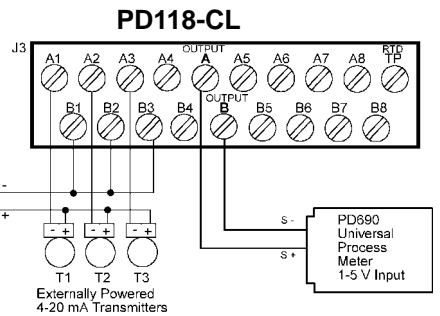

CONNECTIONS OVERVIEW

All connections are made to removable screw terminal connectors which are supplied with each PD118.

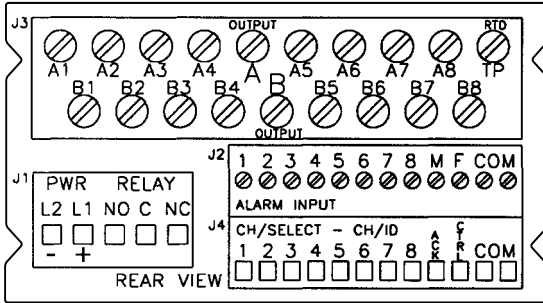

Connector:	Function:
J1	Power input and Alarm relay
J2	Alarm-In, Master-Follower
J3	Signal Inputs and Output
J4	Channel Select/Channel ID with External Ack & CTRL

MOUNTING DIMENSIONS

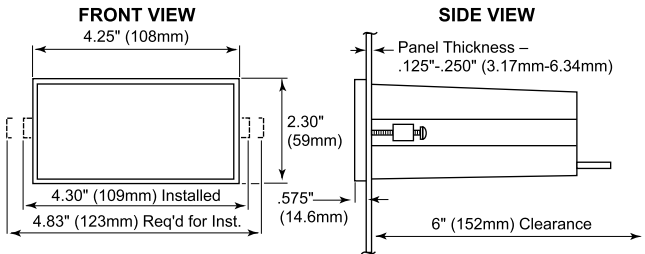

- Notes:**
1. Panel cutout required: 1.772" x 3.622" (45 mm x 92 mm) 1/8 DIN
 2. Panel thickness: 0.125" - 0.250" (3.17 mm - 6.34 mm)
 3. Clearance: allow 6 inches (152 mm) behind the panel
 4. Weight: 16 oz (454g)

DISCLAIMER: The information contained in this document is subject to change without notice. Precision Digital makes no representations or warranties with respect to the contents hereof, and specifically disclaims any implied warranties of merchantability or fitness for a particular purpose.

Please visit the Precision Digital website at www.predig.com for complete information on the entire line of Precision Digital products, technical information and much more.

YOUR LOCAL DISTRIBUTOR IS:



alpha
CONTROLS & INSTRUMENTATION

MESSAGE LABELS

Alarm message labels for the PD118 may be factory printed at no charge, or field printed using a laser printer with clear self-adhesive labels.

Factory printed message labels may be ordered at any time by completing the following form. (Note: message #1 is the top message on the left side and #2 is below it. #5 is the top message on the right side.)

Make copies of this page for additional message labels.

_____ Please include label with my order

_____ I have the PD118, please send ASAP

Quantity _____

Name _____

Title _____

Company _____

Mailing Address _____

City, St., Zip _____

Phone _____

Fax _____

E-mail _____

PO# _____

Custom printed free of charge. Area available per message is 1.25" x .22" (32 mm x 6 mm); user may specify any size and length that will fit in this area. One line of 14 characters at 9 point type will fit.

Message Number 1

--	--	--	--	--	--	--	--	--	--	--	--	--	--	--

Message Number 2

--	--	--	--	--	--	--	--	--	--	--	--	--	--	--

Message Number 3

--	--	--	--	--	--	--	--	--	--	--	--	--	--	--

Message Number 4

--	--	--	--	--	--	--	--	--	--	--	--	--	--	--

Message Number 5

--	--	--	--	--	--	--	--	--	--	--	--	--	--	--

Message Number 6

--	--	--	--	--	--	--	--	--	--	--	--	--	--	--

Message Number 7

--	--	--	--	--	--	--	--	--	--	--	--	--	--	--

Message Number 8

--	--	--	--	--	--	--	--	--	--	--	--	--	--	--

LDS118 Rev B 02/02