

# MODEL PD687-EX 3½ DIGIT FM & CSA LOOP-POWERED EXPLOSION-PROOF METER



ACTUAL SIZE DIGITS

- **1 Volt Drop**
- **1" High Display**
- **Operates from -40 to 80°C**
- **Easy Calibration**

## SPECIFICATIONS

Except where noted all specifications apply to operation at +25°C.

**Input:** 4-20 mA @ 24 VDC Maximum

**Display:** 1.0" (25.4 mm) high LCD, -1000 to +1999

**Calibration:** Two-step; non-interacting zero and span

**Calibration:** 4 mA input: -1000 to +1000;  
20 mA between 20 to 2000 counts greater than 4 mA display

**Maximum Voltage Drop:** 1 VDC @ 20 mA

**Accuracy:** ±0.1% FS ±1 count

**Display Update Rate:** 2.5/second

**Connections:** Screw terminal block

**Operating Temperature:** -40 to 80°C

**Approval:** The PD687-EX is FM Approved and CSA Certified as explosion-proof for Class I, Division 1, Groups B, C, & D; dust-ignition proof for Class II, Division 1, Groups E, F, & G; and Class III hazardous (classified) locations.

**Enclosure:** Explosion-proof cast aluminum with glass window, 0.3% max. copper content, NEMA 4, 7, & 9; IP66; suitable for location in Class I, Division 1, Groups B, C, & D; Class II, Groups E, F, & G, Class III hazardous outdoor (Type 4) locations. One ¼" NPT hole provided.

**Warranty:** 2 years parts & labor

**Extended Warranty:** 1 or 2 years, refer to Price List for details.

**Disclaimer:** The information contained in this document is subject to change without notice. Precision Digital makes no representations or warranties with respect to the contents hereof, and specifically disclaims any implied warranties of merchantability or fitness for a particular purpose.

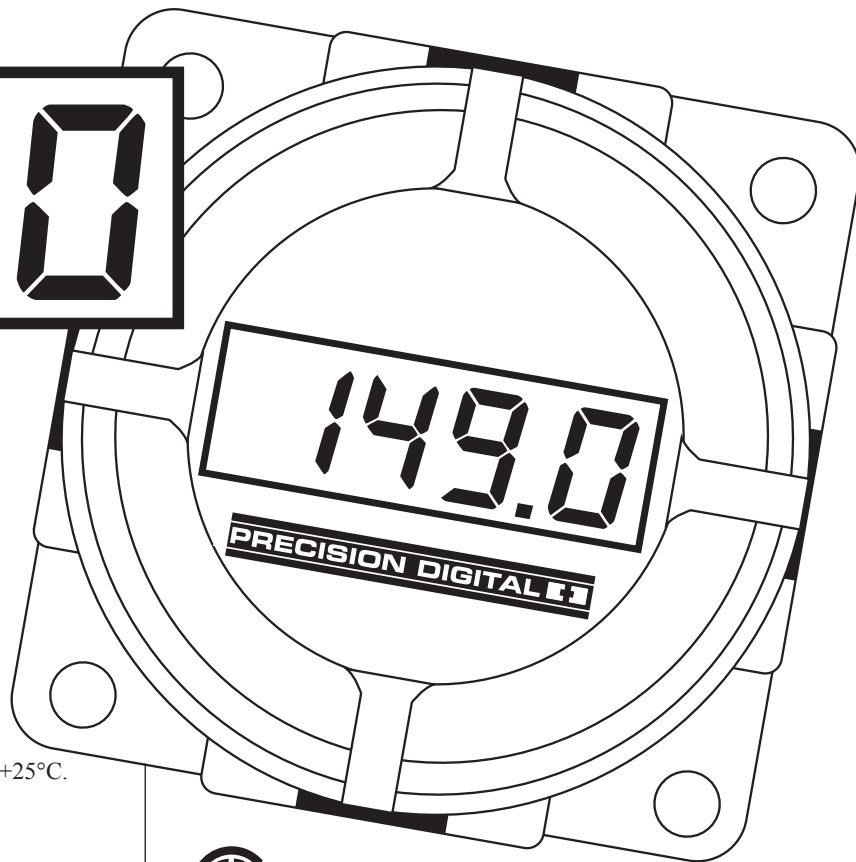

## ORDERING INFORMATION

Model	Description
PD687-EX	FM Approved & CSA Certified Loop-Powered Explosion-Proof Meter
PDA6545	2" Pipe Mounting Kit (4 mounting holes)
PDA6545-SS	2" Pipe Mounting Kit Stainless Steel
PDA6845	2" Pipe Mounting Kit (2 mounting holes)
PDA6845-SS	2" Pipe Mounting Kit Stainless Steel
PDA-SSTAG	Stainless Steel Tag

**YOUR LOCAL DISTRIBUTOR IS:**

# MODEL PD687-EX 3½ DIGIT FM & CSA LOOP-POWERED EXPLOSION-PROOF METER

**Warning:** If any of the following operations are performed in hazardous areas, all appropriate hazardous area procedures must be followed.

**Warning:** Disconnect from supply before opening. Keep Cover tight while circuits are alive. To prevent ignition of Class I atmospheres, all conduit runs must have a sealing fitting connected within 2 inches of the enclosure.

**Avertissement:** Ouvrir le circuit avant d'enlever le couvercle garder le couvercle bien fermé tant que les circuits sont sous tension. Afin de prévenir l'inflammation d'atmosphères de Classe I, les courses de conduit menant à ce boîtier doivent être connectées avec des garnitures d'étanchéité approuvées à une distance d'au plus 2 pouces du boîtier.

**Warning:** Calibration of the Loop-Powered Display should be performed in a non-hazardous area prior to installing it in its enclosure.

**Caution:** Care should be taken to avoid static electricity damaging the electronic circuitry.

## SETUP

The only tools needed for calibration are a calibrated current source and a screwdriver.

## Decimal Point Selection

The decimal point jumper array is located in the lower right corner of the Display Board next to the display. It is labeled DP1, DP2, DP3. Place a jumper over both pins of DP1 for a display of 199.9, DP2 for 19.99 or DP3 for 1.999.

## Calibration

LO and HI calibration controls are located to the left of the display (see Figure 1). Apply a signal equal to 4 mA and adjust the LO control to display the desired reading. Apply a signal between 16 and 20 mA and adjust the HI control to display the desired reading. Complete the calibration procedure by making any minor adjustments to the LO and HI controls.

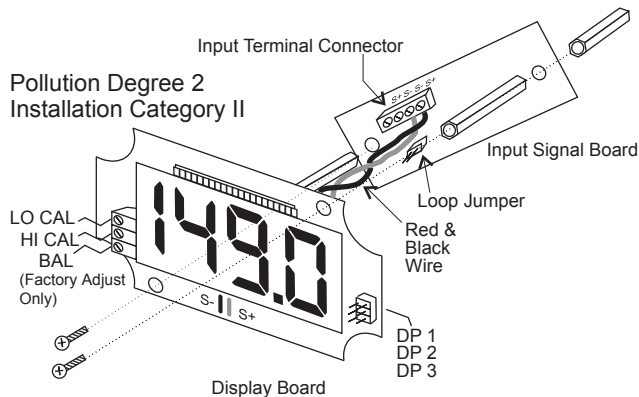

Figure 1. Assembly

## Disassembly from the Enclosure

To access the Display Board and Input Terminals it is necessary to unscrew the enclosure cover and remove the two screws that hold the display cover plate in place. Next, completely loosen the two screws that hold the Display Board and lift it out. The Display Board and the Input Signal Board are connected together with one black and one red wire. The wires are soldered to the Display Board and connected to the Input Terminal connector on the Input Signal Board. Disconnect the black and red signal wires from the Input Terminal connector and lift the Display Board from the enclosure (see Figure 1).

## Servicing Display Board Outside Loop

Two modes of input signal connections allow the user to remove the Display Board for service and maintain the loop connection. This is done by connecting the LOOP JUMPER (see Figure 2) over both pins of the header on the Input Signal Board. The user may now operate the Display Board at another location by connecting a signal directly to the "S+ and S-" wires on the Display Board. When the display of the instrument is put back in service the push-on LOOP JUMPER must be removed from both pins, save the jumper by placing it over one pin only.

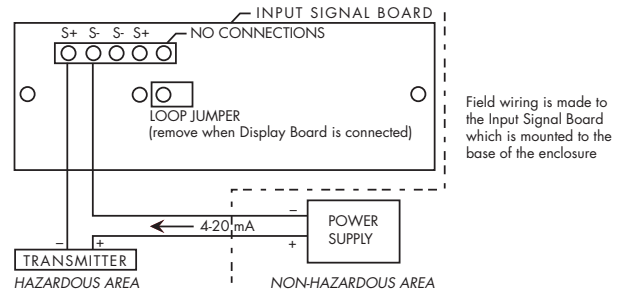

Figure 2. Control Loop Connected to Input Signal Board

## MOUNTING

Refer to Figure 3 for location of mounting holes located in each corner of the enclosure. Mount the enclosure as desired and connect the conduit to the 3/4" NPT hole provided and install sealing fittings as required. Install the Display Board.

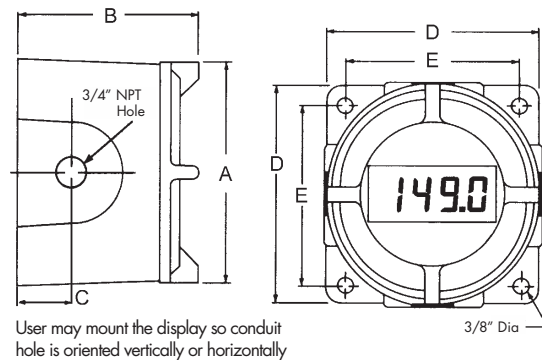

Figure 3. Mounting Dimensions

A: 6.34" (161 mm)    C: 1.5" (38 mm)    E: 5.13" (130 mm)  
B: 5.13" (130 mm)    D: 6.25" (159 mm)    Weight: 8 lb (3.64 kg)

LDS687EX Rev A 05/05