

# DIGITAL PANEL METERS

## Models PD696 - PD698

6 Digit Loop-Powered Flow Rate/Totalizers

### Instruction Manual



PD698  
Explosion-Proof Enclosure



PD697  
NEMA 4X Enclosure



**Available with  
Loop-Powered  
Backlight**



PD696  
1/8 DIN Panel Mount

- 4-20 mA Linear or Square Root Input
- 4½ Digit Rate Display, 6 Digit Total Display
- Total Displayed in any Engineering Unit
- Rate Displayed in Engineering Units per Second, Minute, or Hour
- Programmable Alternating Rate/Total Display
- Low-Flow Cutoff
- Field Selectable Noise Filter
- Non-Volatile Memory, No Battery Needed
- Isolated Open Collector Pulse Output
- Loop-Powered Backlight Option

#### PRECISION DIGITAL CORPORATION

19 Strathmore Road • Natick MA 01760 USA  
Tel (800) 610-5239 • Fax (508) 655-8990

**PRECISION  
DIGITAL** 

[www.predig.com](http://www.predig.com)

**TABLE OF CONTENTS**

Specifications	4
Setup and Programming Overview	5
Connections	7
Programming	8
Calibration	10
Low-Flow Cutoff (LOW FLOW)	11
Noise Filter	11
Totalizer Programming	13
Time Base (TIME)	13
Totalizer Conversion Factor (TOTAL F)	13
Totalizer Decimal Point (TOTAL DP)	14
Parameter Combinations	14
Isolated Pulse Output (PULSE)	15
Display Contrast (CONTRAST)	16
Lockout	16
Display Selection (DISPLAY)	16
Operation	18
Default Display (DISPLAY 1 or DISPLAY 2)	18
Totalizer Reset (RESET)	18
Low Signal Detector	18
Installation	19

**ORDERING INFORMATION**

<b>MODEL</b>	<b>DESCRIPTION</b>
PD696-N	Panel Mount Loop-Powered Totalizer
PD696-B	Panel Mount Loop-Powered Totalizer with Loop-Powered Backlight Option
PD697-N	NEMA 4X Loop-Powered Totalizer
PD697-B	NEMA 4X Loop-Powered Totalizer with Loop-Powered Backlight Option
PD698-N	Explosion-Proof Loop-Powered Totalizer
PD698-B	Explosion-Proof Loop-Powered Totalizer with Loop-Powered Backlight Option
PD698-N-EX	FM & CSA Explosion-Proof Loop-Powered Totalizer
PD698-B-EX	FM & CSA Explosion-Proof Loop-Powered Totalizer with Loop-Powered Backlight Option

**ACCESSORIES**

PDA6844	Panel Mounting Kit for PD697 (does not provide NEMA 4X seal to the panel)
PDA6845	2" Pipe Mounting Kit for PD697-698
PDA-MAG	Reed Switch Magnet for PD698
PDA-SSTAG	Stainless Steel Tag

## DESCRIPTION

The PD696-PD698 models are microprocessor-based loop-powered flow rate/totalizers with programmable pulse output. They are available in three enclosure types with or without the loop-powered backlight option.

### 1/8 DIN Panel Mount

The PD696 is housed in a standard 1/8 DIN panel mount enclosure with a NEMA 4X front panel.

### NEMA 4X Enclosure

The PD697 is housed in a rugged NEMA 4X enclosure which provides excellent protection against corrosion, windblown dust and rain, splashing water, and hose direct water enabling these units to be mounted virtually anywhere.

### Explosion-Proof Enclosure

The FM Approved and UL/C-UL explosion-proof enclosure of the PD698 allows for installation in Class I, Division 1, Groups B, C, & D; Class II, Groups E, F, & G; and Class III areas.

## PD698's Magnetic Reed Switch

The PD698 has a magnetic reed switch in addition to a push-button switch. The reed switch allows the user to program and operate the meter without having to remove the enclosure cover. Additionally, an external push-button switch can be used to reset the total.

To operate the menu, move the reed switch magnet (PDA-MAG) towards the glass window, just below the display. Moving the magnet towards the glass window will produce the same results as pressing the push-button switch.

To operate the PD698's menu without the reed switch magnet, it is necessary to remove the explosion-proof enclosure cover. The push-button switch (SW1) is located in the lower right corner of the display board, just behind the faceplate.

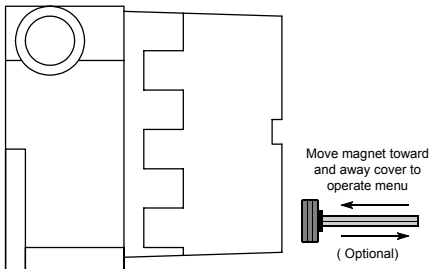
**Caution!**

*When servicing the unit in a hazardous area, all appropriate hazardous area procedures must be followed.*

## SPECIFICATIONS

Except where noted all specifications apply to operation at +25°C.

**Input:** 4-20 mA @ 24 VDC maximum, Linear or Square Root

**Display:** 0.5" (12.7 mm) LCD, 6 digits; Rate: 0 to 19,999. Total: 0 to 999,999

**Linear Input Accuracy:**  $\pm 0.05\%$  FS  $\pm 1$  count

**Square Root Accuracy:**  $\pm 0.1\%$  FS  $\pm 1$  count (10-100% of flow);  $\pm 1\%$  FS (0-10% of flow)

**Decimal Point:** User selectable

**Calibration Range:** User programmable over entire range of meter

**Minimum Input Span:** 1.6 mA between Input 1 and Input 2. An Error message will appear if Input 1 and Input 2 signals are programmed too close together.

**Programming Method:** PD696 & PD697: one front panel button; PD698: one button behind faceplate or reed switch & magnet.

**Noise Filter:** The field selectable noise filter allows the meter to be programmed so that an unsteady (noisy) input can be displayed with greater stability.

**Display Update Rate:** 1/second

**Alternating Display:** Display may be programmed to alternate between rate and total every 10 seconds.

**Minimum Input Current:** 3.5 mA

**Maximum Voltage Drop:** 5.6 VDC @ 20 mA;

Model with backlight option: 7.0 VDC @ 20 mA

**Non-Volatile Memory:** Settings stored for a minimum of 10 years.

**Pulse Output Rating:** Isolated open collector, 24 VDC @ 20 mA; maximum pulse output: 30 pulses/sec; pulse width: 16 ms. If the pulse output exceeds the maximum pulse output (30 pulses/sec), the total will flash and counts will be lost in the totalizer and the pulse output.

**Lockout:** Jumper JP1 restricts modification of programmed settings.

**Totalizer:** Calculates total based on rate and field programmable multiplier to display total in engineering units. Time base available in seconds, minutes, or hours. Time base must be selected according to time units in which rate is displayed.

**Totalizer Conversion Factor:** 0.00001 to 59999

**Total Reset:** Via front panel button or external contact closure

**External Total Reset:** Connect terminals R and CM

**Low-Flow Cutoff:** 0 to 100% FS, user selectable. To disable low-flow cutoff, program cutoff value to zero. Meter does not totalize below low-flow cutoff value.

**Loop-Powered Backlight Option:** Powered directly from the 4-20 mA loop, no batteries required. The display brightness will increase as the input current increases.

**Connections:** Removable screw terminals accept 12 to 26 AWG

**Operating Temperature:** 0 to 65°C

**Storage Temperature:** -30 to 80°C

**Relative Humidity:** 0 to 90% non-condensing

**Approvals:** The PD698-N-EX and PD698-B-EX are FM Approved & CSA Certified as explosion-proof for use in Class I, Division 1, Groups B, C, & D; dust-ignition proof in Class II, Division 1, Groups E, F, & G; and Class III.

**Warranty:** 2 years parts & labor

**Extended Warranty:** 1 or 2 years, refer to Price List for details.

**PD696 Enclosure:** 1/8 DIN, high impact plastic, UL 94V-0; color: black; NEMA 4X, IP65 front panel; panel gasket provided  
**PD696 Weight:** 6.9 oz (196 g)

**PD697 Enclosure:** Impact-resistant glass filled polycarbonate, color: gray, NEMA 4X, IP67; ½" conduit hole provided at base. May be provided on back for panel mounting applications, call factory for details.  
**PD697 Weight:** 10.4 oz (294 g)

**PD698 Enclosure:** Explosion-proof, cast aluminum with glass window, 0.3% max copper content, corrosion resistant polyester powder coating, color: safety blue. NEMA 4X, 7, & 9, IP66; FM Approved & UL/C-UL Certified: Class I, Division 1, Groups B, C, & D, Class II, Groups E, F, & G, Class III; Class I, Zone 1 AEx d IIC hazardous outdoor (Type 4X) locations. IEC rating: Ex d IIC IEC 60529 IP66. Two ¾" NPT holes provided.  
**PD698 Weight:** 5.7 lb (2.6 kg)

---

## SETUP AND PROGRAMMING OVERVIEW

Programming and installing the PD696-PD698 involves three basic steps

1. Connections (page 7)
  - a. Signal input
  - b. External reset
  - c. Pulse output
  
2. Programming
  - Calibration (page 10)
    - a. Decimal point
    - b. 4-20 mA Display values
    - c. Square root extraction (if needed)
    - d. Low flow cutoff (if needed)
    - e. Noise Filter (if needed)
  - Totalizer Programming (page 13)
    - a. Time base
    - b. Totalizer conversion factor
    - c. Totalizer decimal point
    - d. Open collector pulse output (if needed)
  - Display (page 16)
    - a. Contrast
    - b. Lockout
    - c. Alternating rate and total display
  
  - Operation (page 18)
    - a. Default Display
    - b. Totalizer Reset

**PD697 and PD698 Disassembly**

The removable screw terminal connector is located on the lower input signal board. To access these input terminals it is necessary to remove the display board from the input signal board. This is done by first removing the enclosure cover. Next, loosen the 2 screws that hold the display board to the standoffs. Slide and rotate the display board so the left side comes off the standoff first, proceed to remove the display board from both standoffs. Be careful to avoid contact of the display with rough surfaces. The display board may be disconnected from the ribbon cable by pulling up on the ribbon cable connector located on the input signal board. Connect a 4-20 mA input signal to terminal J1 located on the input signal board as shown below. The screw terminal connector can be removed to facilitate wiring.

**Caution:**

*When re-assembling the circuit boards, tighten the screws enough to snug against the faceplate and hold it in place. Over-tightening may cause damage to the screws and the faceplate.*

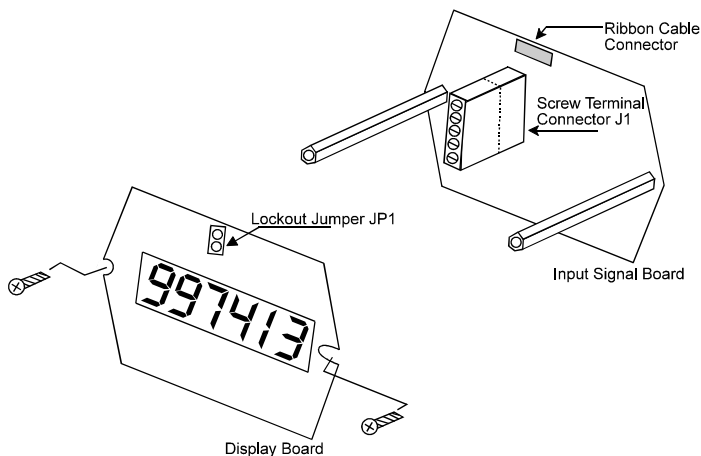

Pollution Degree 2  
Installation Category II

**CAUTION:** DISCONNECT FROM SUPPLY BEFORE OPENING. KEEP COVER TIGHT WHILE CIRCUITS ARE ALIVE. CONDUIT SEALS MUST BE INSTALLED WITHIN 18 INCHES OF THE ENCLOSURE.

**ATTENTION:** OUVRIR LE CIRCUIT AVANT D'ENLEVER LE COUVERCLE GARDER LE COUVERCLE BIEN FERME TANT QUE LES CIRCUITS SONT SOUS TENSION. UN SCHELLEMENT DOIT ETRE INSTALLE A MOINS DE 450 mm DU BOITIER.

**Note:**

The PD696 screw terminal connector is located at the back of the instrument.

## CONNECTIONS

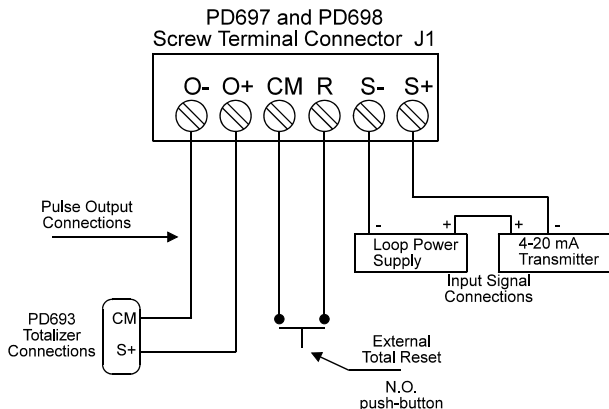
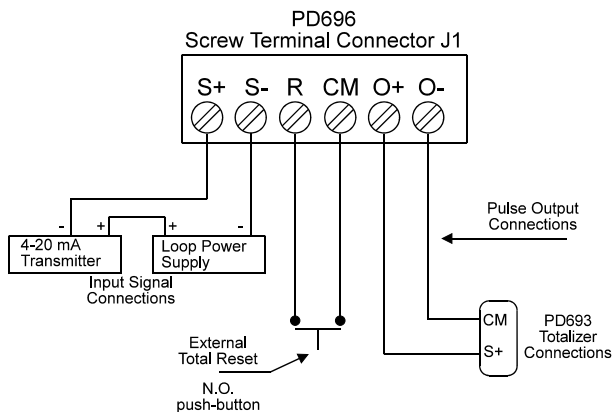
**Note:**

When using a four-wire transmitter connect the transmitter's positive signal terminal to S+ and the negative signal to S-.

## WIRING INSTRUCTIONS

**CAUTION:** Use supply wires suitable for 5 degrees C above surrounding ambient.

1. All field connections to be made with insulated copper wire, either solid or stranded. Tighten all screw terminals to 4.5 lb-in (0.5 Nm). Strip length = ¼ in (7mm). **DO NOT** pre-treat wire with solder.
2. All terminals: Use AWG #22-12 wire. If using AWG #20 or smaller wire, up to 2 wires may be connected to each terminal. If using AWG #18 or larger wire, only 1 wire may be connected to each terminal.

## PROGRAMMING

The **Single Button Scaling** technique is used to program many of the functions, which include Calibration, Totalizer setup, and Display setup. The general procedure is to press the front panel button to accept a flashing display or to wait for the display to scroll and push the button when the desired display appears. The first time the front panel button is pressed, the meter scrolls through the standard programming routine titles: **dSPY t**, **rSEt t**, **CAL lb**, **CutoFF**, **F ILtEr**, **t bASE**, **tot CF**, **tot dP**, **PuLSE**, **dSPRAY**, and **ContSt**.

The following flowchart overviews the PD696 - PD698 programming routines.

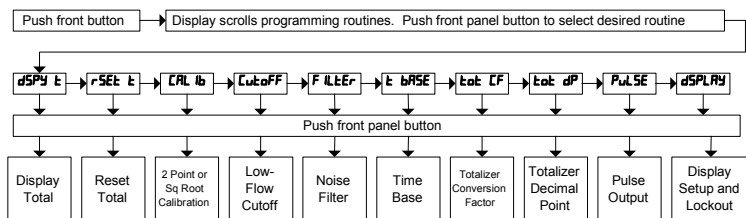

### There are 5 basic programming instructions

1. If the flashing display is OK, push the front panel button before it stops flashing to accept it.
2. If the flashing display is not OK, (or if the button was not pushed in time to accept it), wait for the first digit to flash.
3. If a flashing digit is OK push the button before it starts to scroll to accept it.
4. If a flashing digit is not OK, (or if the button was not pushed in time to accept it), wait for the digit to scroll, and push the button when OK.
5. Digits will scroll until the button is pushed. When a digit is accepted by pushing the button, the next digit to the right flashes.

### Calibration Error

An **Error** message during calibration indicates that the calibration process was not successful. The meter should be recalibrated.

The **Error** message will appear if Input 1 signal and Input 2 signal are too close together, see specifications.

The **Error** message will appear if Input 1 signal is inadvertently also applied for Input 2 calibration, or the button is pushed before applying Input 2.

**Display Functions and Messages**

<b>Display</b>	<b>Parameter</b>	<b>Description</b>
<b>dSPY t</b>	Display Total	Sets the total as the default display (page 18)
<b>dSPY r</b>	Display Rate	Sets the rate as the default display (page 18)
<b>rSEt t</b>	Reset Total	Resets the totalizer to zero (page 18)
<b>CAL Ib</b>	Calibration	To calibrate unit using a calibrated signal source (page 10)
<b>L iNEAr</b>	Linear Input	Programs meter for linear calibration (page 10)
<b>Sq rEt</b>	Square Root	Programs meter for square root extraction calibration (page 10)
<b>iNPE 1</b>	Input 1 Signal	Calibrates display for low input signal
<b>iNPE 2</b>	Input 2 Signal	Calibrates display for high input signal
<b>CutoFF</b>	Low-Flow Cutoff	Programs unit to display zero below user programmed cutoff point (page 11)
<b>F ILTEr</b>	Noise Filter Value	Sets the filter value for noisy signals (page 11)
<b>bYPASS</b>	Filter Bypass	Sets the filter bypass in % of F.S. (page 11)
<b>t bASE</b>	Time Base	Programs correct time unit factor (seconds, minutes, or hours) (page 13)
<b>tot CF</b>	Totalizer Conversion Factor	Rate multiplier to display total in any engineering unit (page 13)
<b>tot dP</b>	Totalizer Decimal Point	Sets the decimal position for the totalizer (page 14)
<b>PuLSE</b>	Pulse Output	Programs the pulse output (page 15)
<b>dSPLAY</b>	Display	Programs default display mode (page 16)
<b>ContSt</b>	Display Contrast	Sets the display contrast (page 16)
<b>d IAG</b>	Diagnostics	Software version number (factory use)
<b>r 19999</b>	Overrange	Display overrange
<b>r -9999</b>	Underrange	Display underrange
<b>Error</b>	Error	Calibration not successful (page 8)

## CALIBRATION

Calibration is performed using the front panel button. It does not require any tools or disassembly of the meter. A calibrated signal source is required. The calibration input signals must be within the range of the meter and there must be an absolute difference between Input 1 and Input 2 greater than 1.6 mA.

**For best results, allow the meter to warm-up for at least 15 minutes.**

1. Push the front panel button, when **CAL 1b** appears push the button again.
2. Next, **BBBBBB** will be displayed and a decimal point will travel from left to right. Push the front panel button when the decimal point is in the desired position. If no decimal point is desired, push the button when decimal point is NOT shown.
3. **L nERr** or **59 rE** will be displayed alternately. Press the button when **L nERr** is displayed for normal 2-point linear calibration. Press the button when **59 rE** is displayed for square root extraction calibration.
4. Meter flashes **InPt 1**. Apply Input 1 signal **THEN** push the front panel button, (e.g. 4 mA).
5. All digits flash for 3 seconds.  
If this is the desired display for Input 1, push the button before entire display stops flashing, (meter will then flash **InPt 2**). Go to step 10 below.  
  
If this is not the desired display, (or if the button was not pushed in time to accept the display) wait for the first digit to flash.
6. The first digit flashes for 3 seconds before it scrolls. This digit can only be "0" or "1", in the rate display mode, it will display 0-9 in the totalizer mode.
7. When flashing digit is OK, push the button, next digit will flash for 3 seconds before it scrolls.
8. Repeat step 7 for each remaining digits.
9. When last digit has been accepted the entire display will flash for 3 seconds. Press the front panel button within 3 seconds if OK to complete Input 1 calibration. If not OK, wait for first digit to flash again and go to step 6 above.
10. Meter flashes **InPt 2**. Apply Input 2 signal **THEN** push the front panel button, (e.g. 20 mA). All digits flash for 3 seconds.
11. Go to step 6 above.

## LOW-FLOW CUTOFF (**L<sub>u</sub>t<sub>o</sub>FF**)

The Low-Flow Cutoff allows the PD696 Series to be programmed so that the often unsteady output from a differential pressure transmitter at low flow rates always displays a zero on the rate display. Factory default is 000000 (disabled).

### To Program Low-Flow Cutoff

1. Push the front panel button, when **L<sub>u</sub>t<sub>o</sub>FF** appears push the button again. Rate digits flash for 3 seconds.  
If this is the desired low flow cutoff value push the button before the entire display stops flashing.  
  
If this is not the desired low flow cutoff value, (or if the button was not pushed in time to accept the display) wait for the first digit to flash.
2. First digit flashes for 3 seconds before it scrolls.
3. When flashing digit is OK, push the button; next digit will flash for 3 seconds before it scrolls.
4. Repeat step 3 for each remaining digit.
5. When last digit is accepted the entire display will flash for 3 seconds. Press the button within the 3 seconds if OK to complete low flow cutoff programming. If NOT OK, wait for first digit to flash and go to step 2 above.

**Example:** If low flow cutoff is set at 1200, any rate less than 1200 will be displayed as “0”.

To disable low flow cutoff, program cutoff value to zero.

## NOISE FILTER

The field selectable noise filter allows the meters to be programmed so that an unsteady (noisy) input can be displayed with greater stability.

Increasing the filter value will help stabilize the display, however this will reduce the display response rate. The filter level may be set anywhere between 2 and 999. Factory default is 20.

### Noise Filter Bypass

The Noise Filter averages any minor changes in the input signal and displays the reading with greater stability. Quick, small input spikes will not be immediately reflected on the display. However, the meter can be programmed to filter only small changes. Larger input changes can be displayed immediately by setting a Noise Filter Bypass value. If the input signal spikes beyond the Noise Filter Bypass value the signal will **NOT** be averaged but rather immediately reflected on the display. The noise filter bypass value may be set anywhere between 0.2% and 99.9% of full scale. Factory default is 2.0. Increasing the noise filter bypass value will slow down the display response rate.

**Program Noise Filter and Noise Filter Bypass value**

1. Push the front panel button, when **F ILtEr** appears push the button again.
2. All digits flash for 3 seconds.  
If this is the desired filter value push the button before the entire display stops flashing.  
If this is not the desired filter value, (or if the button was not pushed in time to accept the display) wait for the first digit to flash.  
Digit flashes for 3 seconds before it scrolls.
3. When digit is OK, push the button next digit to the right will flash for 3 seconds before it scrolls.
4. When flashing digit is OK, push the button, next digit to the right will flash for 3 seconds before it scrolls.
5. When right most digit is OK, press the button.
6. Entire display will flash for 3 seconds. Press the button within the 3 seconds if OK. If NOT OK, wait for left digit to flash and go to step 2 above.
7. **bYPASS** appears, then the display shows the current Noise Filter Bypass value.
8. All digits flash for 3 seconds.  
If this is the desired bypass value push the button before the entire display stops flashing.  
If this is not the desired value, (or if the button was not pushed in time to accept the display) wait for the first digit to flash.  
Digit flashes for 3 seconds before it scrolls.
9. When digit is OK, push the button, next digit to the right will flash for 3 seconds before it scrolls.
10. When flashing digit is OK, push the button, next digit to the right will flash for 3 seconds before it scrolls.
11. When right most digit is OK, press the button.
12. Entire display will flash for 3 seconds. Press the button within the 3 seconds if OK. If NOT OK, wait for left digit to flash and go to step 8 above.

## TOTALIZER PROGRAMMING

### TIME BASE (t BASE)

The meter must be programmed with the time base. The Time Base is the time unit in which the rate is displayed. For example, if the rate display is set up for gallons per hour then the time base must be set to hours. The factory default is in *seconds*. The rate and total conversion factor are used to calculate the total.

#### To Set the Time Base:

1. Push the front panel button, when **t BASE** appears push the button again.
2. The display will start to scroll between the selections of **SEC**(seconds)\*, **MIN**(minutes), **Hour**(hours).
3. Press the button when desired time base selection appears.

### TOTALIZER CONVERSION FACTOR (tob CF)

The Totalizer Conversion Factor is a number that is multiplied by the rate to compute the total. For example, if the rate display is gallons per hour and the total is desired in barrels (1 gallon = .02381 barrels), a total conversion factor of 0.02381 should be used. If the rate display is gallons per hour and the total is desired in gallons, a factor of 1 should be used.

The conversion factor has a selectable decimal point. Because the decimal point is mathematically significant values such as 1.0000\*, 1.000, 1.00, 1.0, and 1 produce identical results. The decimal point should be set so as to produce the best resolution for the application.

The maximum value for the totalizer conversion factor depends upon the decimal point selection.

#### To Set Totalizer Conversion Factor

1. Push the front panel button, when **tob CF** appears push the button again.
2. **BBBBBB** will be displayed and a decimal point will travel from left to right. Push the button when the decimal point is in the desired position. If no decimal point is desired, push the button when decimal point is NOT shown.
3. Next, the display shows the current totalizer conversion factor settings.  
If this is the desired display push the button before entire display stops flashing.

If this is not the desired display, (or if the button was not pushed in time to accept the display) wait for the first digit to flash.

4. First digit flashes for 3 seconds before it scrolls.
5. When flashing digit is OK, push the button; next digit will flash for 3 seconds before it scrolls.
6. Repeat step 5 for each remaining digit.
7. When last digit is accepted the entire display will flash for 3 seconds. Press the button within the 3 seconds if OK to complete totalizer conversion factor setup. If not OK, wait for first digit to flash and go to step 3 above.

\* Factory default.

## TOTALIZER DECIMAL POINT (Tot dP)

The decimal point for the totalization display is field selectable and can be placed at any position.

### To set Totalizer Decimal Point

1. Push the front panel button, when **Tot dP** appears push the button again.
2. **BBBBBB** will be displayed and a decimal point will travel from left to right. Push the button when the decimal point is in the desired position. If no decimal point is desired, push the button when decimal point is NOT shown.

## PARAMETER COMBINATIONS

Certain extreme combinations of parameter selections may exceed the totalizer range of the meter. If this occurs the totalizer might lock-up after a programming operation or it might lose counts. Steps to correct this situation are:

**Decrease** the total conversion factor.

**or**

**Decrease** the number of decimal places in total.

**or**

**Increase** the time base (seconds to minutes or minutes to hours.)

It is recommended to set the rate to zero during programming to prevent lock-up. If a lock-up occurs, disconnect the signal and connect it back making sure the signal is equivalent to a zero rate. This will unlock the totalizer and allow changes to the related parameters.

## ISOLATED PULSE OUTPUT (PULSE)

The isolated pulse output signal can be programmed to produce 1 pulse output per any accumulated total between 1 and 999. For example, the PD696-PD698 can be programmed to produce one pulse for every 500 gallons totalized.

The isolated pulse output signal is calibrated using the front panel button and uses the same **Single Button Scaling** technique that is used to calibrate the input signal.

### Pulse Output Calibration

1. Push the front panel button, when **PULSE** appears push the button again.
2. Digits flash for 3 seconds  
If this is the desired display at which the meter will produce 1 pulse output, push the button before entire display stops flashing. The meter will return to display rate or total.  
  
If this is not the desired display, (or if the button was not pushed in time to accept the display) wait for the first digit to flash.
3. First digit flashes for 3 seconds before it scrolls.
4. When first digit is OK, push the button; next digit will flash for 3 seconds before it scrolls.
5. When second digit is OK, push the button; next digit will flash for 3 seconds before it scrolls.
6. When last digit is OK, push the button.
7. Entire display will flash for 3 seconds. Press the front panel button within the 3 seconds if OK to complete the pulse output calibration. If NOT OK, wait for first digit to flash and go to step 3 above. Factory default is 100.

**Note:**

If the pulse output exceeds the maximum output specification (30 pulses/second), the total will flash and output pulses will be lost.

## DISPLAY CONTRAST (Cont5t)

Display Contrast allows the user to adjust the contrast of the display.

To optimize the display contrast, press the front panel button. When **Cont5t** is displayed press the button again.

A special pattern “**o°o°o°o°**” will be shown and the contrast will automatically increase and decrease.

Press the button when the desired contrast is displayed.

## LOCKOUT

Install jumper JP1 to restrict modification of calibration values. When the front panel button is pushed with the lockout jumper in place only **dSPY r**, **dSPY t**, **rSEt t**, and **dSPRAY** routine titles are shown, if selected.

The PD696's JP1 jumper is located at rear of instrument.

The PD697's and PD698's JP1 jumper is located on the top of the display board.

## DISPLAY SELECTION (dSPRAY)

With the lockout jumper in place the routine titles of **dSPY r**, **dSPY t**, **rSEt t**, and **dSPRAY** can still be accessed. The **dSPRAY** menu is used to program the meter to:

1. Display rate only or display total only.
2. Automatically alternate between displaying rate and total every 10 seconds.
3. Restrict the total from being reset.

**See chart on next page**

### To block or change the display titles

1. Push the front panel button, when **dSPRAY** appears press the button again.
2. The display will start to scroll between the selection choices of **dSPY r**, **dSPY t**, and **rSEt t**.
3. Press the button when desired routine title appears.
4. Display will flash **YES** or **no** alternately. Press the button when **YES** is flashing to unblock title from being displayed. Press the button when **no** is flashing to block title from being displayed.
5. Next title appears, go to step 3.
6. After last title is selected meter will revert to normal indication mode.

**Alternating Display**

The display may be programmed to alternate between rate and total every 10 seconds.

To automatically alternate between rate and total select **no** for both **dSPY r** and **dSPY t** (see Display Selection (**dSPLAy**) above).

**Display Selection Choices (dSPLAy)**

Menu Display	Choice	Result
<b>dSPY r</b> <b>dSPY t</b>	<b>YES</b> <b>YES</b>	Manually select display rate or display total
<b>dSPY r</b> <b>dSPY t</b>	<b>no</b> <b>YES</b>	Display total only
<b>dSPY r</b> <b>dSPY t</b>	<b>YES</b> <b>no</b>	Display rate only
<b>dSPY r</b> <b>dSPY t</b>	<b>no</b> <b>no</b>	Automatically alternate between rate and total every 10 seconds
<b>rSEt t</b>	<b>YES</b>	Able to reset total to zero with front panel button
<b>rSEt t</b>	<b>no</b>	NOT able to reset total

**Notes:**

1. Select **no** for both **dSPY r** and **dSPY t** to program display to alternate between rate and total every 10 seconds.
2. Total can be reset with an external switch even if **rSEt t** is set to **no**.

## OPERATION

### DEFAULT DISPLAY (*dSPLY t* or *dSPLY r*)

If the meter is programmed for manual display, the user may select either rate or total to be set as the default displayed reading. When displaying rate an “r” symbol is displayed at left side of the display.

#### Switching Default Display

1. Push the button, when *dSPLY t* or *dSPLY r* appears, push the button again.
2. Default display will switch from rate to total or vice versa depending on previous setting.

### TOTALIZER RESET (*rSEt t*)

#### To reset the totalizer to zero via the front panel

1. Push the front panel button, when *rSEt t* appears, push the button again.
2. The total will reset to zero and start totalizing immediately.

#### To reset the totalizer to zero via a user supplied remote push button.

1. Connect a momentary (normally open) push button to terminals R and CM.
2. Closing the contacts will reset the total to zero. The totalizer will start totalizing once the contacts are re-opened.

## LOW SIGNAL DETECTOR

These meters have circuits that monitor the loop signal. To protect against data loss the meter will shut down when the current falls below specifications.

At power-up the meter performs a self-test and flashes the display for a few seconds. If the signal is below specifications the meter will not start up.

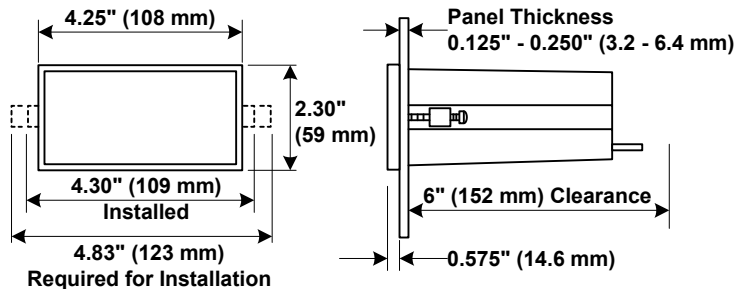
**INSTALLATION****PD696 Panel Mount****Notes:**

1. Panel cutout required: 1.772" x 3.622" (45 mm x 92 mm) 1/8 DIN
2. Panel thickness: 0.125" - 0.250" (3.2 mm - 6.4 mm)
3. Clearance: allow 6 inches (152 mm) behind the panel

**PD697 NEMA 4X**

Installation of the PD697 involves removing the display board from its enclosure and connecting 1/2" conduit fittings to the hole provided. It may be necessary to remove the input signal board depending on type of conduit hubs used. Wall mounting holes are located in each corner of the enclosure.

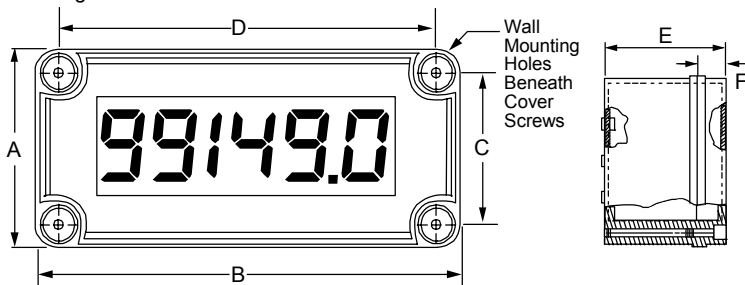

- A: 3.15" (80 mm)    C: 2.36" (60 mm)    E: 2.56" (65 mm)  
 B: 5.51" (140 mm)    D: 4.72" (120 mm)    F: 0.79" (20 mm)

**PD698 Explosion-Proof**

Installation of the PD698 involves removing the display board from its enclosure and connecting  $\frac{3}{4}$ " NPT fittings to the holes provided. It may be necessary to remove the input signal board depending on type of fittings used. Wall mounting holes are located in two corners of the enclosure.

**Caution!**

*When servicing the unit in a hazardous area, all appropriate hazardous area procedures must be followed.*

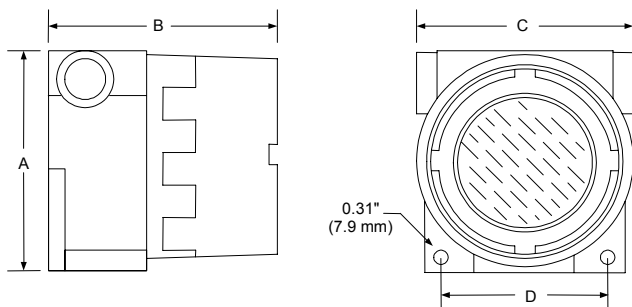

A: 5.62" (143 mm)    C: 5.43" (138 mm)  
B: 5.62" (143 mm)    D: 4.06" (103 mm)

**Disclaimer**

The information contained in this document is subject to change without notice. Precision Digital makes no representations or warranties with respect to the contents hereof, and specifically disclaims any implied warranties of merchantability or fitness for a particular purpose.



[www.predig.com](http://www.predig.com)

LIM696\_G.doc  
SFT004 Ver 1.020 & up  
09/05